



**Robust Pumping Solutions for  
Biogas Industry**



## HELPING BIOGAS INDUSTRY WITH ROBUST PUMPING SOLUTION

Biogas is the ideal energy solution for today's world. It provides clean fuel to generate the electricity & thus meets the power demand and reduces the load on the local power grid. It produces organic manure for farming as a by-product. It also significantly reduces water and land waste.

Roto Pumps has developed a new range of Progressive Cavity Pumps specially designed to meet the growing needs of the Biogas Industry. In biogas production, the pumping application requires efficient transfer of varied highly viscous & solid laden biowaste media.



- › Digestate
- › Grass & Corn silage
- › Food waste
- › Whole plant silage
- › Liquid & Solid manure
- › Municipal waste (Biological portion)
- › Waste fodder
- › Fish & Slaughterhouse waste
- › Faecal sludge
- › Cereal shreds
- › Pomace
- › Sugar beet



# ROTO PUMPS IN BIOGAS INDUSTRY



**DIGESTATE TRANSFER PUMP**  
Flow – 75 m<sup>3</sup>/hr, Pressure – 10 bar



**LIQUID MANURE PUMP**  
Flow – 40 m<sup>3</sup>/hr, Pressure – 4.5 bar



**BIOMASS RECIRCULATION PUMP**  
Flow – 80 m<sup>3</sup>/hr, Pressure – 4 bar



**BIOMASS TRANSFER PUMP**  
Flow – 40 m<sup>3</sup>/hr, Pressure – 3 bar

# BIOMASS PUMP RANGE

Roto Biomass pump developed on 'Maintenance in place' platform is used for recirculation of fermentation tank slurry and feeding to digestate storage tanks. This pump range is also available in vertical configuration and it is used in open lagoons to transfer organic manure.

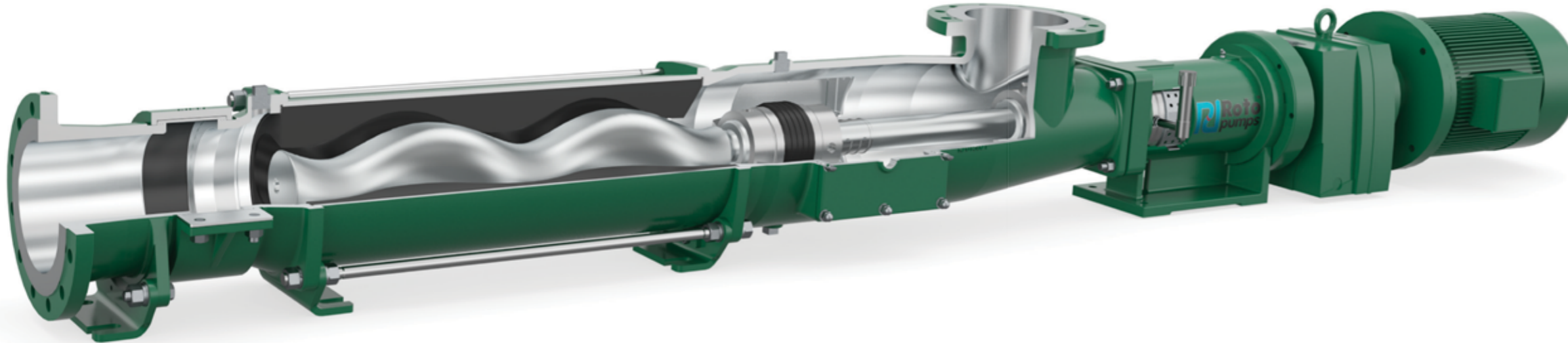

Model	582	602	621/632	641/652	661/662	681	692	701
Capacity in m <sup>3</sup> /hr at 100 RPM	4	6	11	17	24	36	44	47

Higher capacity & higher pressure pumps are also available on request. Different orientation & multiple opening pump housing options are also available.

## Distinctive Features & Benefits

- Quick Maintenance in Place Pump
- Rotor, Stator & Joint parts can be easily replaced without dismantling suction and delivery pipelines
- Heavy-duty Bearing Housing Directly Coupled with geared motor
- Specially Designed Double Cartridge Mechanical Seal
- Heavy duty Cardan Universal Joint with Reinforced Boot Seal and Protector Rings
- Antiblock Arrangement at the Entry of Stator

## Applications

- Biomix Feed
- Press Separator
- Pasteurized Biomass
- Condensed Substrate
- Transfer of Digestate to Biomix Unit & Open Lagoon or Storage Tank

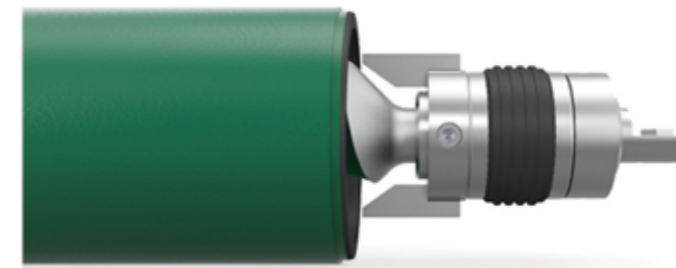

Antiblock (Sweeper) Arrangement



6 Opening Pump Housing



# BIOMIX PUMP RANGE

Roto Biomix pumps have been integrated into the process of renewable energy generation and are constantly upgraded and optimized to meet the customer's demand. These pumps are used to mix and transfer solid bio waste and digestate liquid into the fermentation tank. Customized hopper available in round & rectangular shape up to 3 meter length.

Model	701	720	730	740
Capacity in m <sup>3</sup> /hr at 100 RPM	47	66	98	133

Higher capacity & higher pressure pumps are also available on request.

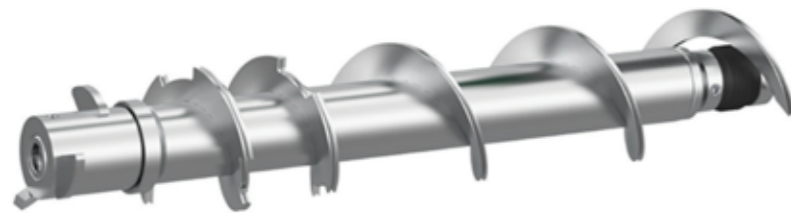
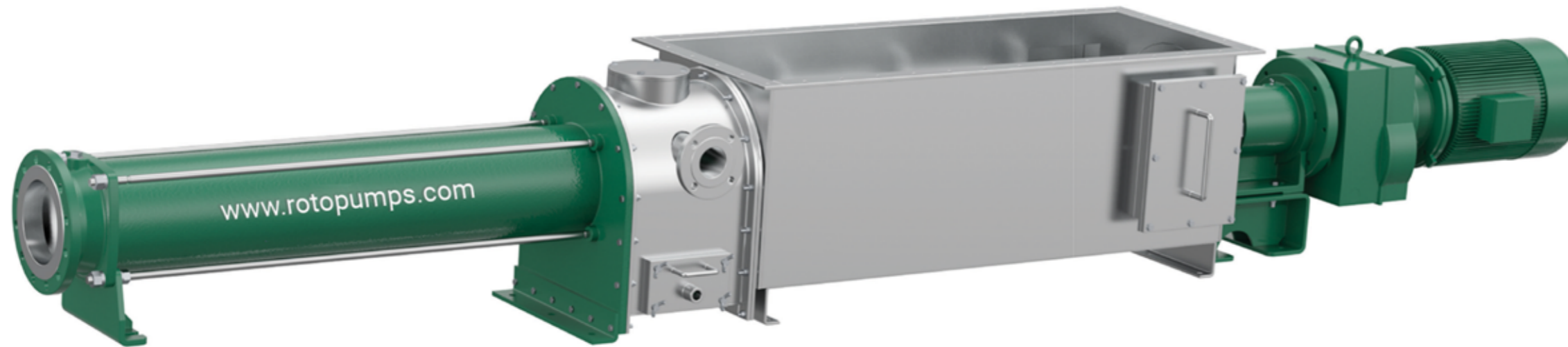

### Large Auger - Feed Screw

Designed for crushing & mixing of dry to wet media and feeding of substrate. Option available in plasma nitrided coating.

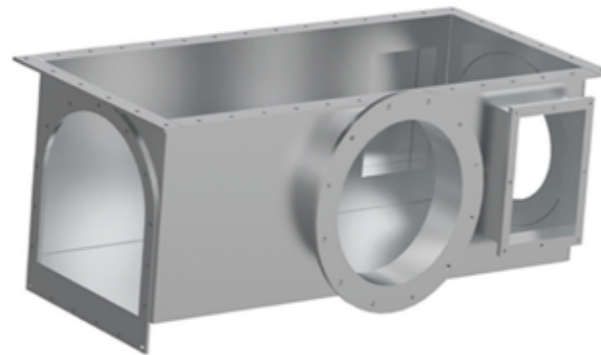

### Rectangular Hopper

Hopper option available with additional large inlet flange for substrate mixing.

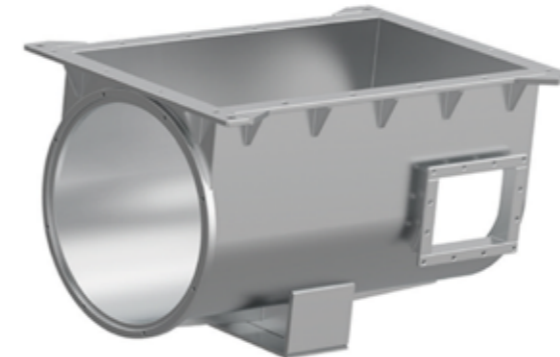

### Round Hopper

Designed to handle a high degree of dry solid content.

### Inspection Cover

For easy access, quick inspection and maintenance.

### Stone Catcher

Designed to trap large solid particles inside the hopper.

### Heavy Duty Bearing Housing

Capable of taking high axial thrust and can be directly coupled with geared motor.

### Inbuilt Feed Flange

Left handed & right handed port included as standard for feeding of digestate to ensure optimum homogenization.

### Cardan Universal Joint

Universal joint with sleeve protector & flight wing to avoid any solid build up.

### Smarter Shaft Sealing

Cartridge dual mechanical seal with oil lubrication plan for longer life.



## ROTO PUMPS LTD.

### Regd. Off. & Global Headquarters

13, Roto House, Noida Special Economic Zone,  
Noida-201305, UP, India  
Tel: +91 120 2567902-5, Fax: +91 120 2567911  
Email: [contact@rotopumps.com](mailto:contact@rotopumps.com)  
CIN: L28991UP1975PLC004152

### Overseas Establishments

#### Roto Pumps Ltd. United Kingdom

Email: [sales@rotopumps.co.uk](mailto:sales@rotopumps.co.uk)  
Web : [www.rotopumps.co.uk](http://www.rotopumps.co.uk)

#### Roto Pumps Ltd. Australia

Email: [sales@rotopumps.com.au](mailto:sales@rotopumps.com.au)  
Web : [www.rotopumps.com.au](http://www.rotopumps.com.au)

#### Roto Pumps North America Inc.

Email : [sales@rotopumpsna.com](mailto:sales@rotopumpsna.com)  
Web : [www.rotopumpsna.com](http://www.rotopumpsna.com)

#### Roto Pumps Africa (Pty.) Ltd.

Email : [sales@rotopumps.co.za](mailto:sales@rotopumps.co.za)  
Web : [www.rotopumps.co.za](http://www.rotopumps.co.za)

#### Roto Pumpen GmbH

Email : [sales.rpg@rotopumps.com](mailto:sales.rpg@rotopumps.com)  
Web : [www.rotopumps.com](http://www.rotopumps.com)

#### Roto Pumps (Malaysia) Sdn. Bhd.

Email : [salesmy@rotopumps.com](mailto:salesmy@rotopumps.com)  
Web : [www.rotopumps.com.my](http://www.rotopumps.com.my)

[www.rotopumps.com](http://www.rotopumps.com)