

Pressure Transmitters

Pressure,
Flow, Level
and Density
measurement

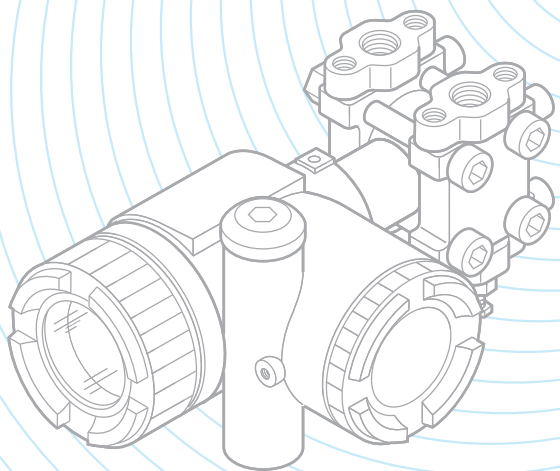

FOX-AII



Contents

3.....	Introduction
4.....	A transmitter at the edge of technology
5.....	Micro capacitance based technology
6.....	Optional functionality
8.....	Transmitter measurement diaphragm materials
9.....	Level and remote seal transmitters
9.....	High temperature and high vacuum level applications
10.....	“Custom built” technology
11.....	2 sites dedicated to transmitter production
12.....	Quality & Environment
13.....	Services
14-15.....	Oil & Gas applications
16-17.....	Nuclear applications
18-19.....	Energy metering applications
20.....	Differential pressure devices for flow measurement
21.....	Accessories for pressure transmitters
22-23.....	Food & beverage, pharmaceutical and cosmetic applications
24-25.....	Chemical applications
26-27.....	Paper applications
28-29.....	Water & environment applications
30-31.....	Various process applications
32-34.....	Technical specifications
35.....	Our range of Fuji Electric products



Introduction

Fuji Electric Co., Ltd. Group

Founded in Japan in 1923, the Fuji Electric Co., Ltd. Group is recognised as one of the world leaders in electrical power equipment, industrial controllers and instrumentation. With over 7 billion dollars in turnover and 25 740 employees worldwide, Fuji Electric's engineers and technicians play an active part in all technological innovations in the field of energy optimisation and savings. Thanks to the experience it has acquired in developing electronic components and perfect command of the most recent technologies, Fuji Electric proposes products which are perfectly adapted to applications in most industrial sectors : production, electrical energy transport and industrial equipment.



Fuji Electric France S.A.S.

A subsidiary of Fuji Electric Co., Ltd., the French company products and markets in Europe the instruments that have built the Japanese group's worldwide reputation. As a recognised specialist in pressure transmitter manufacture, our area of expertise also covers all industrial instrumentation : measurement, inspection, regulation, combustion gas analysis and energy optimisation. Over the last 20 years, our base in Clermont-Ferrand and the recent extension in Cournon-d'Auvergne have enabled us to guarantee the best manufacturing times for our pressure transmitters and to provide a quality local service to our customers.

Whatever the industrial sector of activity (oil & gas, chemicals, paper, food production, nuclear, energy, water & environment, etc.), Fuji Electric France can assist you throughout the product life cycle : diagnostic, advice, solution, commissioning, operating and maintenance assistance, to provide the best solutions for your issues.

A transmitter at the edge of technology



FCX-AII V5

Considered as one of the leaders in the pressure measurement field, Fuji Electric has installed numerous FCX transmitters around the world. Boosted by its experience and with the constant desire to meet its users' requirements, Fuji Electric France has continually enhanced the FCX-AII V5 into the best referring appicate transmitters of its generation. Thanks to the wide variety of ranges available and the numerous customisation possibilities, the FCV-AII version 5 pressure transmitter can adapt to all applications, whatever the industrial sector.

The detecting cell in the FCX-AII V5 series cover measurement ranges between 1 mbar and 500 bar in differential, relative and absolute pressure. They are also adapted for level, density, interface and rate measurements. For specific applications, our engineers can assist you with a wide choice of remote seal mountings. The standard accuracy of 0.065% (up to 0.04% optional), the wide turndown (from 1 to 100) and the diversity of materials available for wetted parts (Tantalum, Monel, Hastelloy C or PVDF) expand the scope : chemicals, petrochemicals, energy, steel-making, paper, food & beverage or water treatment.

Benefiting from electronic progress in microprocessor and LSI circuit integration, the FCX-AII V5 transmitter offers users excellent repeatability. The FCX-AII V5 is available in a "Smart" version (4-20 mA + superimposed digital signal) with the Fuji proprietary protocol and the Hart® protocol. It may also be equipped as an option with the Fieldbus Foundation H1 protocol. The FCX-AII V5 transmitter's modular design enables interchangeability with different elements and so quick and easy maintenance for the appliance.

Micro capacitance based technology

Accuracy : **Standard** $\pm 0.065\%$ of the calibrated span
 Option $\pm 0.04\%$ of the calibrated span

Long term stability : $\pm 0.1\%$ max. span / 10 years

Differential pressure transmitters for static pressures up to 1035 bar (15 000 PSI)

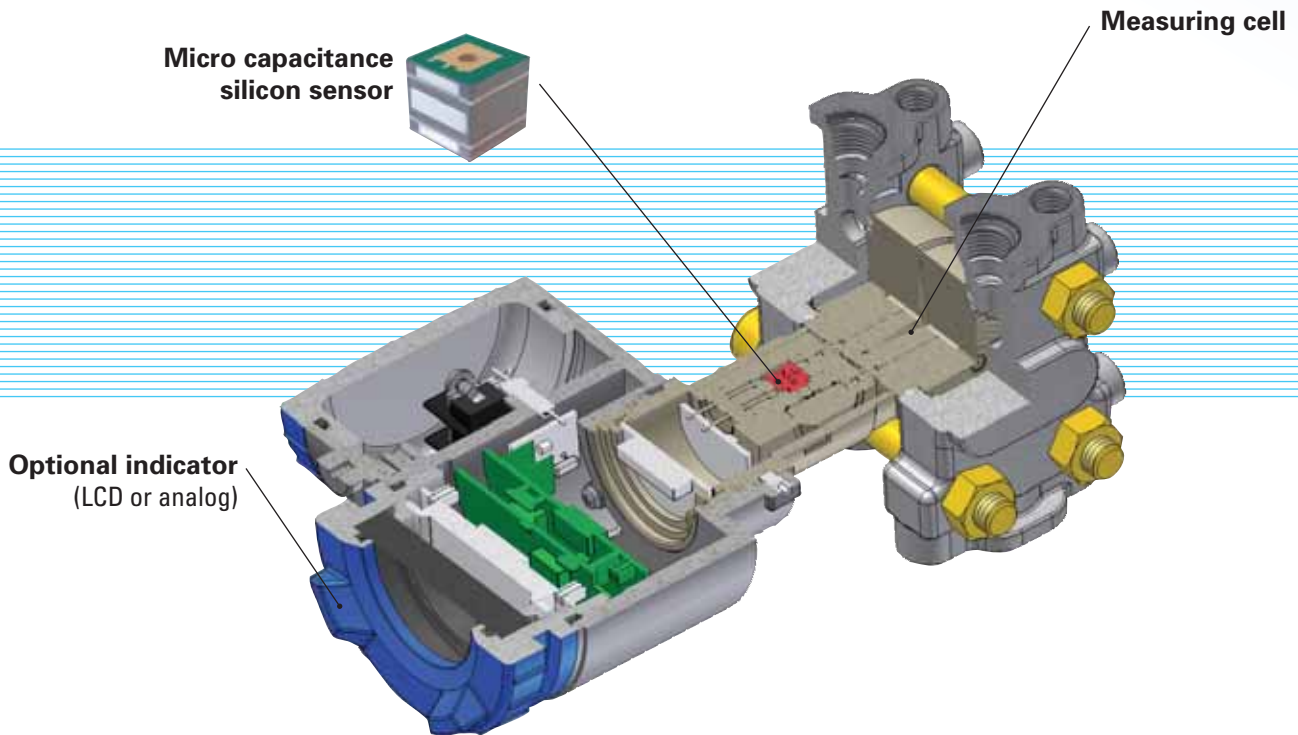

Using their experience in microprocessor components and semi-conductors, Fuji Electric's engineers have developed a capacity effect micro-sensor from a silicon chip, as a sensitive element in the measurement cell. Using a silicon measurement diaphragm enables hysteresis and mechanical fatigue problems to be limited on the sensitive element and so provide the user with very high zero stability and long term reliability.

The FCX-All V45 transmitters are manufactured according to the ISO 9001 quality standard. The sensitive element receives the differential pressure, which causes the two capacity values to vary. It is mounted "floating" in the neck of the measurement cell to improve the static pressure and temperature characteristics.

Micro capacitance element

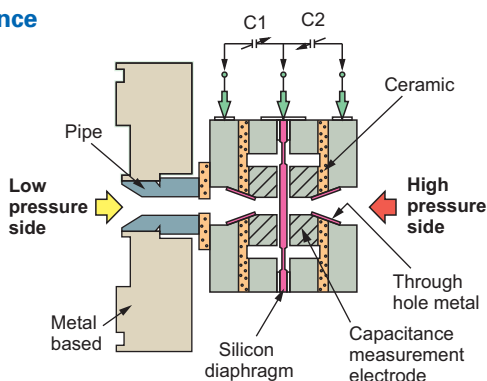

Measuring cell

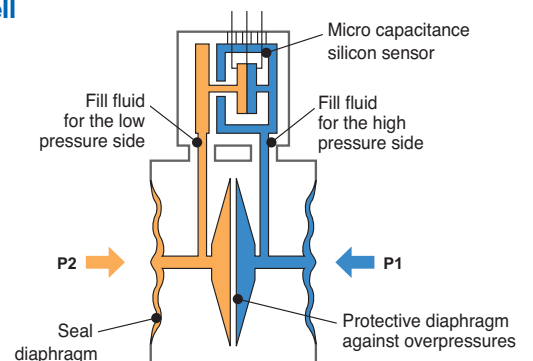

Optional functionality

Digital indicator

The FCX-All V5 transmitter may be equipped with an analog or digital indicator. The digital indicator is based on LCD technology and shows the information on 2 lines each of 6 digits and also includes 3 push buttons. The indicator enables the measurement in physical units and the local configuration of the transmitter.

Main settings :

- Zero/Span calibration without reference pressure service
- Linear or square root signal
- Damping
- Digital indicator configuration
- Zero/Span calibration
- Self-diagnosis
- Output circuit calibration
- Direction and value of burnout

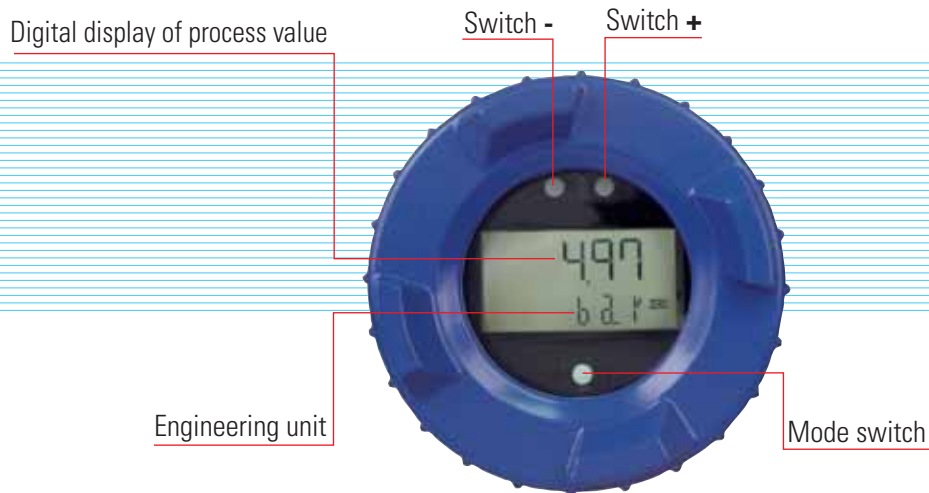

Burnout current

In conformance with the recommendations of NAMUR NE 43, the output of the transmitter can be driven to a specific value should the transmitter experience an internal failure. The standard output signal limits are 3.2 to 22.5 mA. In case of a transmitter failure, the burnout direction can be down scaled (3.2 to 4 mA) or up scaled (20 to 22.5 mA), being programmable.

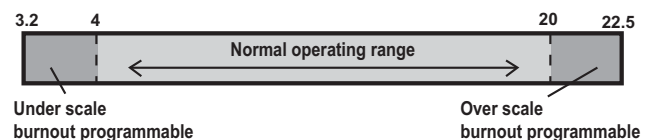

Maintenance functions

The calibration parameters are saved in the transmitter. At any time it is possible to come back to the factory calibration of the transmitter. Min and max temperatures are stored in the transmitter memory.

It is always possible to visualize the values in a specific menu on the screen of the hand held communicator. All the adjustment functions of the transmitter can be locked by a password (the external adjusting screw is also locked).



Communication

The FCX-All V5 pressure transmitter is "Smart" and provide 4-20mA and superposed digital signals and use bilingual language capability which uniquely provide Hart® and Fuji protocol as a standard. In addition, it can be supplied to communicate using either Foundation Fieldbus H1 protocols.

Our hand held communicator (HHC) is a very useful configuration tool for the FCX-All V5 transmitter. As a menu driven device, the HHC can be used to remotely display and configure transmitter parameters :

- Principle programmable parameters :
 - Zero
 - Span
 - Burnout
 - Output signal
 - Auto diagnostic
 - Type of output signal (linear / $\sqrt{}$)
 - Damping
 - Current generation
 - Tag
 - Model number of the transmitter
- 4-line, 16-character liquid crystal display
 - Optional printer



Using the Hart® communication protocol, the FCX-All V5 transmitter can also be configured by any Hart® protocol compatible hand held communicator.

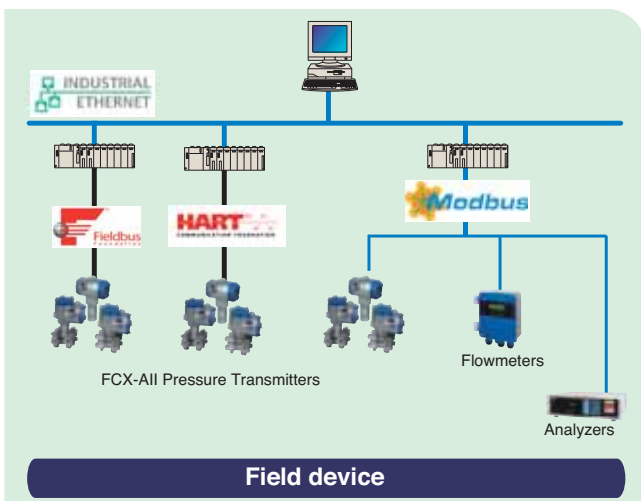

The FCX-All V5 pressure transmitter can also be configured using Hart® communication based software "Hart® Explorer" connected to your Laptop or PC. Configuration of the above parameters is possible and the settings can also be saved for future reference. It's also possible to measure and record process values. The interface between the PC and the transmitter is performed by a mini modem USB / Hart® to guarantee the communication between the PC and the 4 to 20 mA loop of the transmitter.

Hart® / USB modem

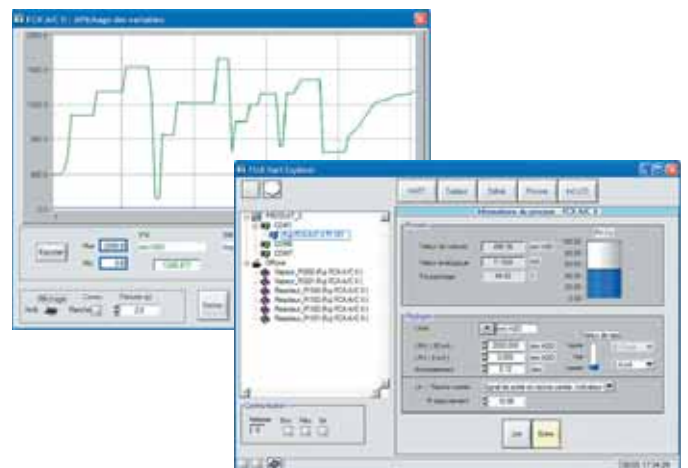

Transmitter measurement diaphragm materials

Gold and Ceramic coating : prevention of hydrogen diffusion in the measurement cell (hydrogen sulphide)

For certain configurations, the process fluids generate hydrogen atoms that may be diffused through the metal diaphragm. The contamination of the oil associated with this diffusion degrades the transmitter's measurement accuracy and life time. Thanks to our gold and ceramic double-coating diaphragm, the hydrogen's permeation is stopped. In this configuration, the transmitters may be used in sulphur reduction installations, hydrogen production units, oil refineries and putrefaction mud treatment works.

Double coating seal diaphragm for the prevention of hydrogen permeation

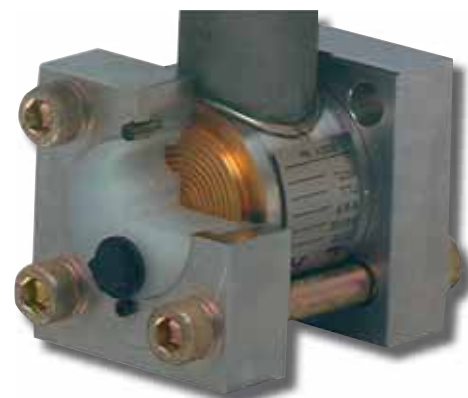
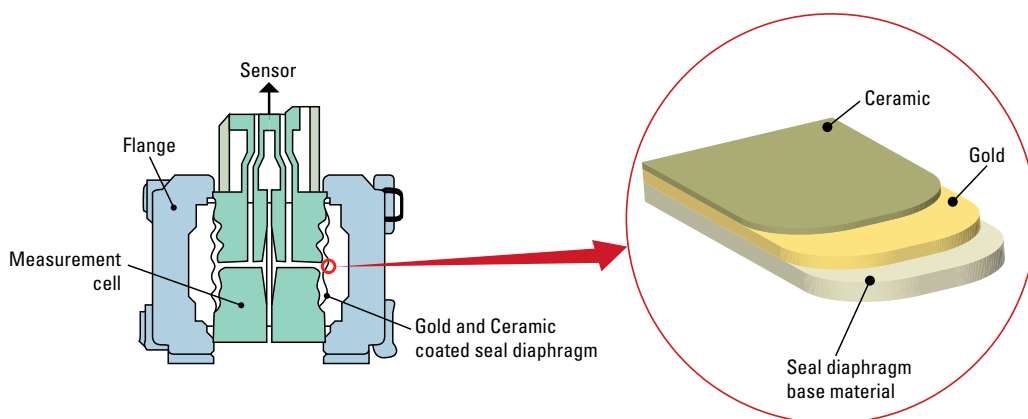

Hastelloy C, Tantalum, Monel : anti corrosive and chemical attacks

Different materials and coatings are available for the pressure transmitter diaphragms to guarantee the longevity and reliability of your measurements.

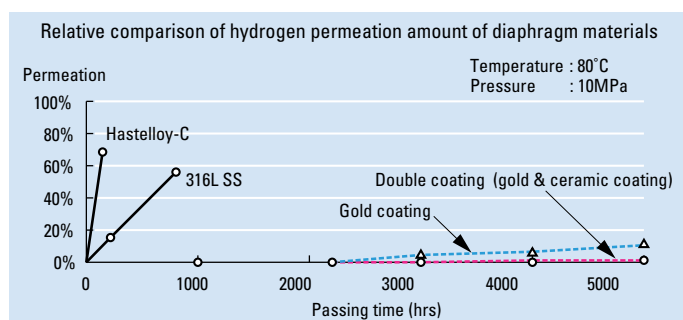

Material	Applications
Gold & ceramic coating	Sulphur reduction installations, hydrogen production units, oil refineries and putrefaction mud treatment works, ionised gas (hydrogen sulphide)
Tantalum	Hydrochloric acid, sulphuric acid, nitric acid, aqua regia
Titanium	Chloride salt, sulphate compound

Material	Applications
Hastelloy C	Organic acid, inorganic acid, alkaline type
Monel	Alkaline type, fluorinated acid
Zirconium	Hydrochloric acid, caustic soda, whitening agent

Level and remote seal transmitters

Fuji Electric France manufactures transmitters which are ideally suited to applications which use aggressive, adhesive, crystallising and highly viscous fluids which are dangerous for the environment or toxic, and for high process temperatures. The diaphragm manufactured in an appropriate material (stainless steel, Hastelloy C, Tantalum, Monel, etc.) enables the measured fluid to be separated.

This means that the most difficult measurement requirements can be satisfied by combining the measurement instrument with remote seals. Numerous types of connection may be adapted to existing or future installations (threaded, screw-in, flange, connectors, axial, radial, "wafer" and hygiene connectors).

The remote seals also have the advantage of having a large contact surface with the fluid and guarantee precise pressure measurement.

Depending on the application (vacuum, temperature, food, etc.), the system is filled with particular, adapted and specific oil (silicon, fluorinated, food, etc.). It transmits the pressure hydraulically to the measurement instrument.

For extreme temperatures (-90 to +400°C), if there are strong vibrations or remote assemblies, capillaries with stainless steel or PVC ducts enable the remote seal to be distanced from the measurement electronics.

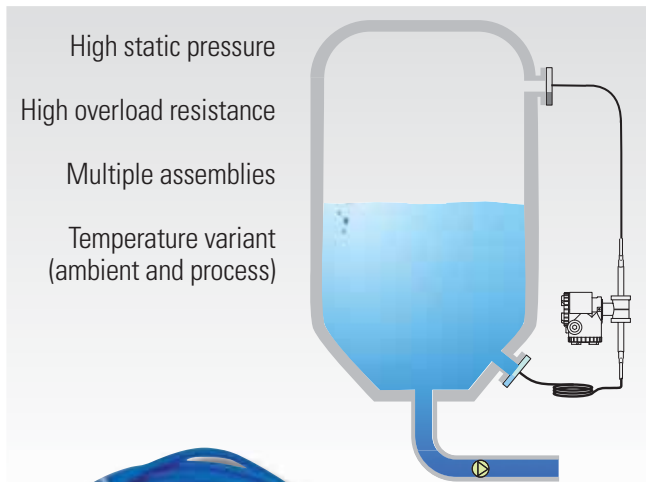

- High static pressure
- High overload resistance
- Multiple assemblies
- Temperature variant (ambient and process)

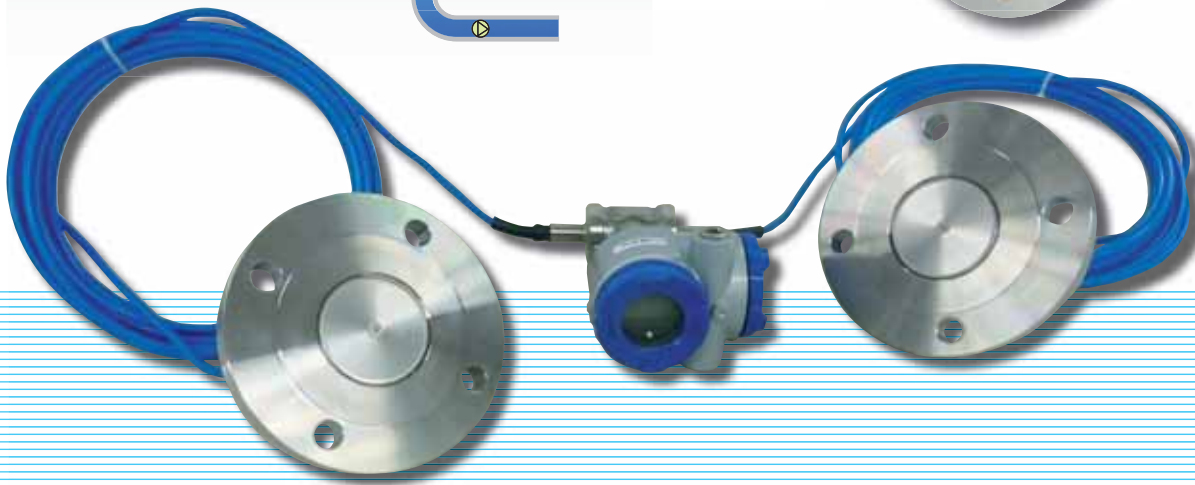

High temperature and high vacuum level applications

Up to 200°C and 0.27kPa abs

Our special treatment for remote seal transmitters enables precise and stable measurement even at high temperatures and high vacuum levels. To guarantee the quality of our appliances, we apply strict controls throughout the manufacturing process:

- Degassing for parts at high temperature and under high vacuum level.
- Vacuum and high temperature treatment for filling fluid.
- Remote seal filling at high temperature and under high vacuum level



“Custom built” technology

Fuji Electric France has a Research & Development department which works closely with customers to find the best solution for their applications.

Flanges, remote seal(s) and specific connections are studied and designed by a team of specialist engineers and technicians (according to customers' specifications) and using powerful IT resources.



1

Raw materials :

Large stock of stainless steels and different noble materials (Hastelloy C, Tantalum, Duplex, etc).



2

Part machining and production :

A workshop comprising a range of machining centres and digital command towers (CN) provides high flexibility to the production unit set up in the new Cournon d'Auvergne (63) factory.

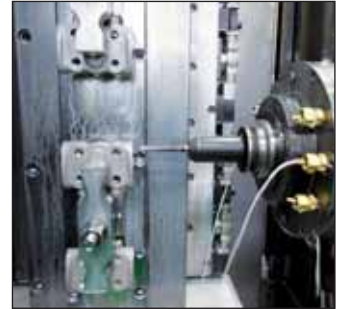

6

Calibration benches :

All Fuji Electric France pressure transmitters are calibrated on computer based automatic benches. The recent design of these calibration systems guarantees high precision and perfect detection of the slightest fault.



5

Cells filling :

Filling pressure transmitter measurement cells is a vital manufacturing stage. Different oils may be incorporated according to the process and the customer's industrial environment.



2 sites dedicated to transmitters production

Two production sites - Clermont-Ferrand and Cournon-d'Auvergne - and modern equipment to meet your specific needs.

Whatever your process, whether you need standard or specific transmitters, our team of specialists is at your disposal to find the concept and solutions which are best adapted to your applications.

3

TIG welding stations :

Manually or automatically-operated, Tungsten Inert Gas welding (TIG) technology guarantees robust and reliable assemblies. These specialised welding facilities enable us to assemble the diaphragm seals, the capillaries and directly mount the seals on the transmitters. All welds are checked by a Helium mass spectrometer to guarantee the integrity of the weld.



Our pressure transmitters are manufactured in France in our 2 productions sites (Clermont-Ferrand and Cournon-d'Auvergne).

4

Clean room :

The cell, the core of the pressure transmitter, is manufactured in a 10 000 class clean room which provides the highest level of assurance.

This installation, which is combined with the other study, machining, assembly and calibration resources, enables Fuji Electric France to control the whole pressure transmitter manufacturing chain and so provide a precise and reliable product which meets the customer's requirements to the letter.

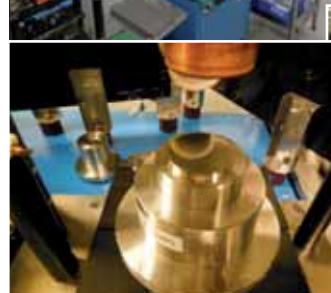

Quality & Environment

To ensure customer satisfaction, Fuji Electric France has set up an integrated management system based on the continuous improvement principle, in accordance with the requirements in the ISO 9001 and ISO 14001 international reference bases.



➤ Quality Certification

ISO 9001 : Quality Management System
(certificate No.1997/8402).

➤ Environmental Certification

ISO 14 001 : Environmental Management System
(certificate No. 2014/59264).

Calibration

All of our pressure transmitters may be provided with a 5-point calibration record using gauges connected to different international systems (ILAC-MRA, Cofrac, DKD, etc.). On request and for specific installations, the traceability of the connection of the measurement instruments used may also be mentioned.



Metrology

Fuji Electric France has its own metrology laboratory in its Clermond-Ferrand (France) factory. A three-dimensional viewing machine enables precise and quick verification of the different mechanical parts which make up the transmitter. Different pressure spans are used to calibrate transmitters under static pressure up to 1400 bar. A high pressure span is used to calibrate our measurement gauges.



Accreditation & Certification

Explosive Atmospheres

ATEX (Europe)
IECEX (World)
CSA (Canada)
FM (United States)

Product conformity

CE (Europe)
GOST (Russia)

Environmental Measurements

TÜV QAL1 EN14181 (Europe)

Product safety

K3-A/1E and K3-AD/1E (EDF Nuclear)
SIL2 (World)
DESP (Europe)

Product Traceability

ISO 15156-3 conformity
NACE MR0175 (World)

Marine-type approval

The FCX-AIII (AII V5) and FCX-AII series have received DNV-GL marine-type approval. The products tested conform to the certification's requirements and are authorised for installation in the locations listed below :

Temperature D : Open deck on a ship with ambient temperatures from -20°C to +70°C

Humidity B : Anywhere on the ship with a humidity rate up to 100%

Vibration B : Equipment such as combustion engine pumps and their associated pumping system

EMC B : Everywhere on the ship, including the deck and the open deck

Enclosure C : Open deck, lower deck, lower plates in the engine room

OIL & GAS APPLICATIONS

Since 1996, Fuji Electric France has been developing specific differential pressure transmitters for oil applications and which are ideally suited to Topside and Subsea applications (depths down to 3500 metres).

Thanks to technology based on a sensitive element which floats in the neck of the cell, our differential pressure transmitters enable flow measurements with the following static pressures :

- 7500 Psi (517 bar),
- 10 000 Psi (690 bar),
- 15 000 Psi (1035 bar),
- 20 000 Psi (1380 bar).



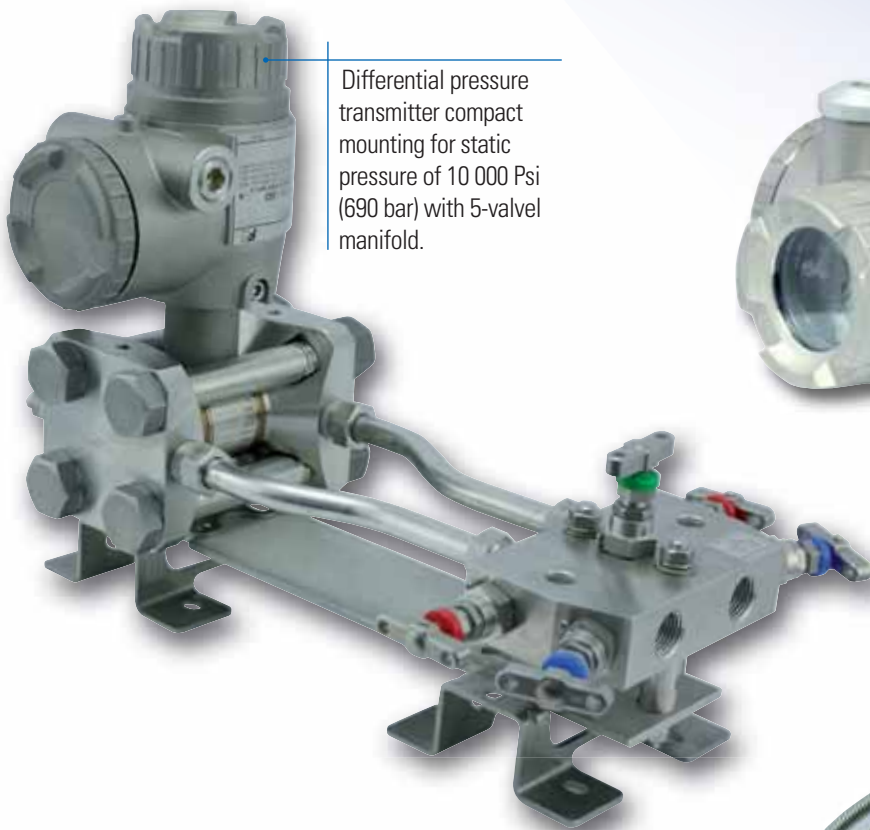

Differential pressure transmitter compact mounting for static pressure of 10 000 Psi (690 bar) with 5-valve manifold.

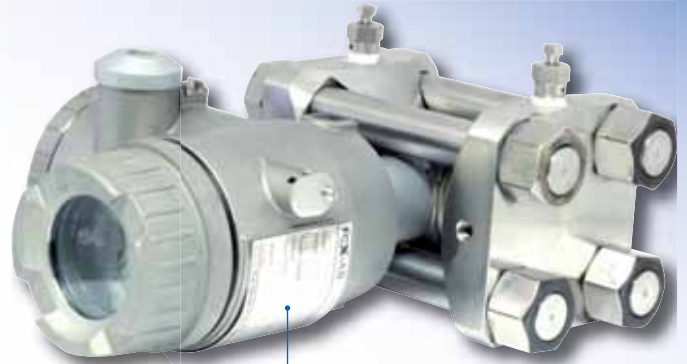

Differential pressure transmitter for high static pressure up to 15 000 Psi (1035 bar).
Application :
Topside flow rate measurements under extreme environmental conditions.

Numerous designs are possible :
Process connection by remote seals for high static pressure differential pressure transmitters (Hub connectors, API, SPO standards or at customer request).



Remote seals & options

Approvals



PED



API Standard



Rinsing ring



Specific remote seals

NUCLEAR APPLICATIONS

As a partner for French and international energy suppliers, operators, constructors, installers, engineering offices and research institutes, Fuji Electric France develops unique expertise, proven by complete command of qualification maintenance, production and control processes.

Our pressure transmitters are K3-A/1E and K3-AD/1E qualified and are designed for applications which require earthquake and radiation qualification under normal conditions.

The implementation of quality and nuclear safety requirements and qualification processes is guaranteed by our know-how and the experience we have acquired since our company was created.

In order to meet our customers' safety requirements, Fuji Electric France is committed to a strict quality process dedicated to the nuclear industry, at all levels of our industrial organisation: personnel skills qualification and management, procurement and third party supplier traceability, manufacturing process control, documentation and customer technical support.

French subsidiary of Fuji Electric Group Co. Ltd., Fuji Electric France ensures a global presence. Commercial and technical offices providing international support nearby and an appropriate quick response to the nuclear industry needs.





"K3-A, K3-AD category" classified or no classified digital or analog pressure transmitter (absolute, relative or differential pressure).

Reference bases :
 ISO 9001 v.2008 ISO
 14001 HAF604 ATEX
 QN100/QN200/QN300
 RCC-E ed. 2007 and 2012



Non classified or "K3-AD category" classified or no classified digital or analog remote seal(s) pressure transmitter (relative or differential pressure).



Options



Removable electrical connectors (Souriau, SAIB & Jaegger)



Local digital indicator



HP and LP inverter

ENERGY METERING APPLICATIONS

The main functions of the energy metering solutions proposed by Fuji Electric France enable energy consumption to be reduced and the energy produced or consumed via the Water, Air, Gas and Steam networks to be measured, invoiced and optimised.

A complete range of differential pressure mechanisms (Pitot tube, micro-venturi, edge, diaphragm, annular chamber, venturi, nozzles, V-shaped cone) and associated accessories provide precision fluid measurement under the most extreme conditions.

The corrected flow measurements proposed meet current ISO5167, ASME MFC-3M, DIN, BS 1042, API 2530 and NF X10-112 construction standards and may be used as part of commercial transactions.

Our measurement devices conform to European Directive 97/23 EC.

In addition to our measurement and metering appliances, our team can offer you the study, supply, installation, maintenance and calibration of your heating or cooling energy metering solution.



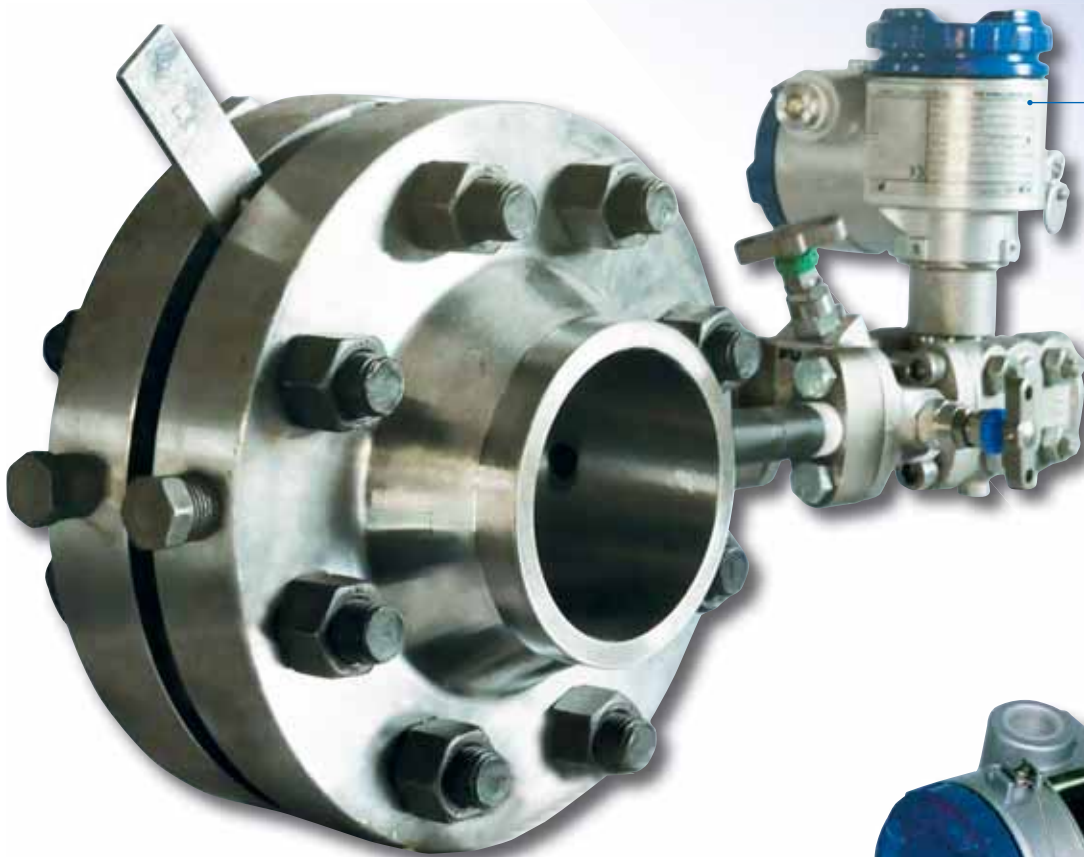

Flow measurement by differential pressure device (orifice plate) for application on gas, liquid and steam.



Relative or absolute gas, steam or liquid pressure measurement via a manometric connector.

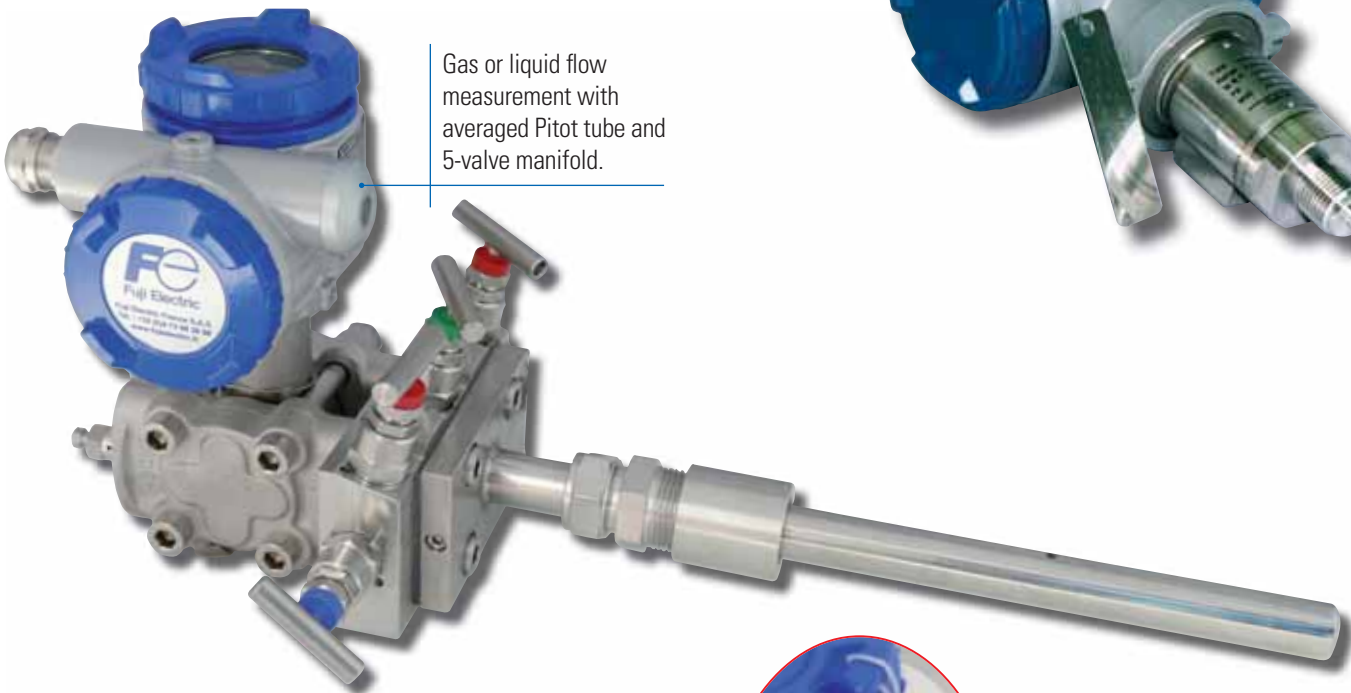

Gas or liquid flow measurement with averaged Pitot tube and 5-valve manifold.

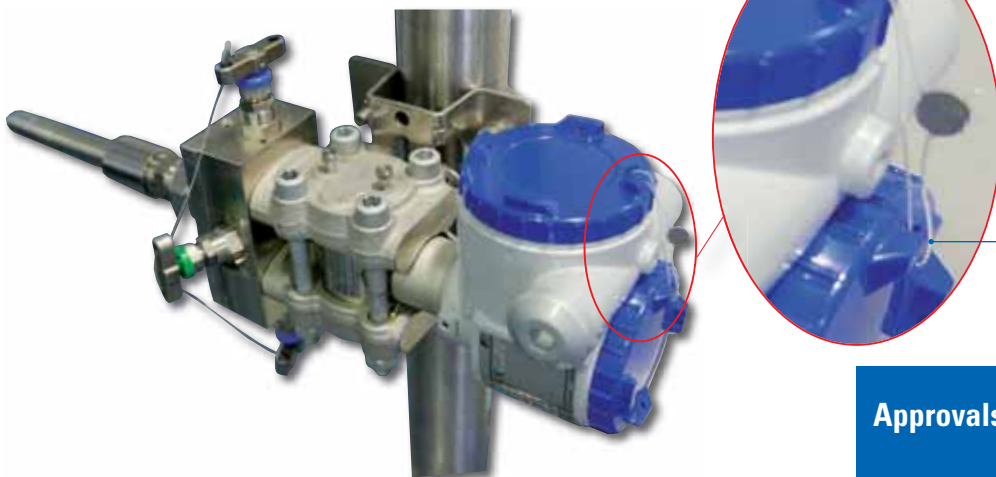

For metering applications for commercial purposes, special electronic unit covers are proposed as an option for sealing operations.

Approvals



Differential pressure devices for flow measurement

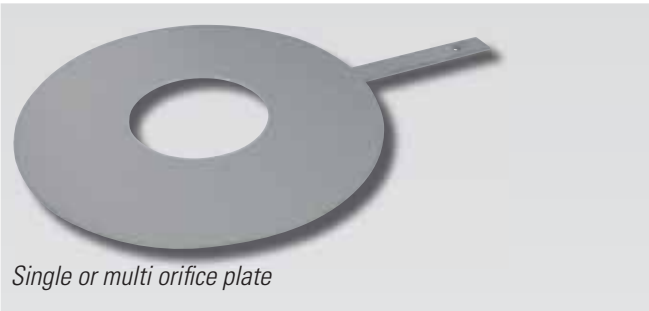

Single or multi orifice plate



Monoblock orifice and annular chambers



Nozzles



Wedge



V-shaped cone

Depending on the complexity and variety of different applications in flow measurement by differential pressure, Fuji Electric has and offers a range of pressure devices (orifice plate or diaphragm, venturi tube and nozzle) in order to find the best suitable solution to your process.



Integrated orifice plate



Venturi

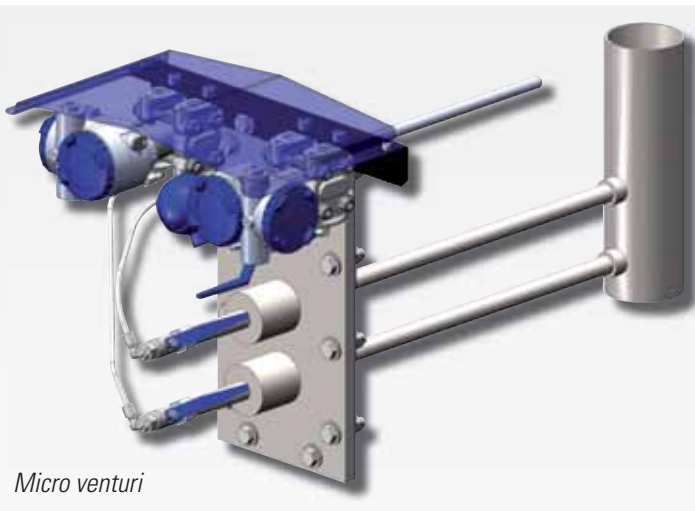

Micro venturi

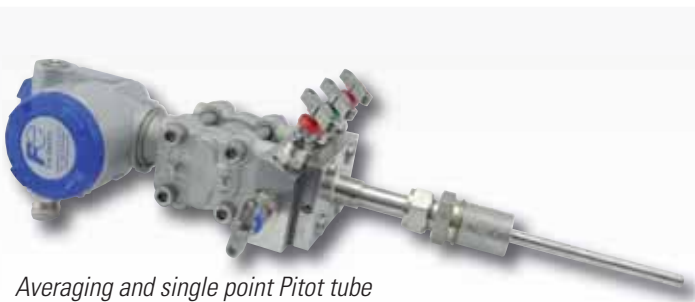

Averaging and single point Pitot tube

Accessories for pressure transmitters



Manifolds



Condensation collectors



Expansion siphons



Insulation valves



Standard or ADF glands

Accessories for reliable and easy pressure transmitter mounting in the process :

- Insulation valves, expansion siphons, pressure gauges, manifolds that can be used for steam applications and at high temperatures.
- Condensation collectors, connectors, plugs and glands.

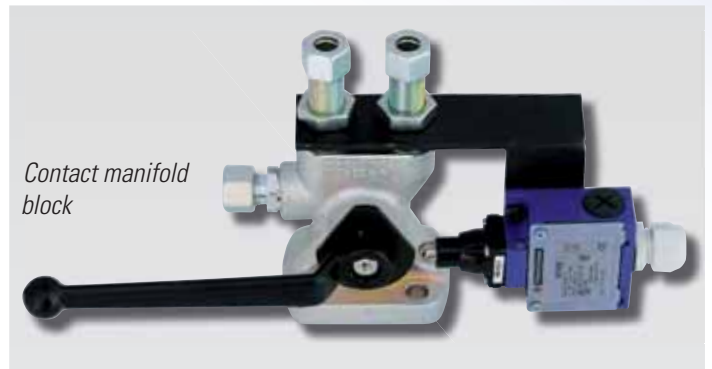

Contact manifold block



BIM block

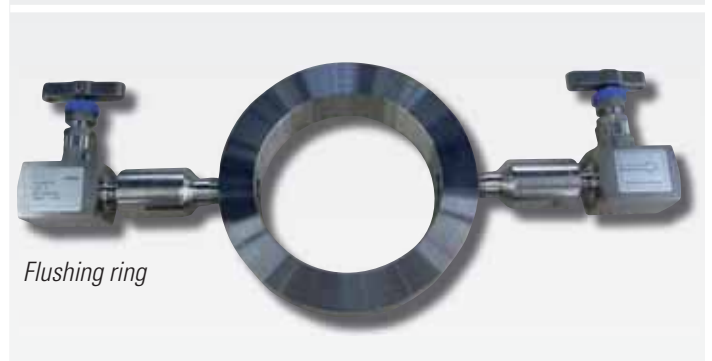

Flushing ring



Protection enclosures

FOOD & BEVERAGE, PHARMACEUTICAL AND COSMETIC APPLICATIONS

Thanks to the numerous references and approvals available for food & beverage, pharmaceutical and cosmetic applications, Fuji Electric France manufactures hygienic relative, absolute and differential pressure transmitters that guarantee safety and reliability for your measurements.

A wide range of process connections is available for applications in sterile environments (DIN11851 (food connectors), DIN32676 (Clamp connectors), DIN11864, NEUMO[®], VARIVENT[®]).

The design, the materials and the roughness of the pressure treatment surfaces respect international EHEDG (European Hygienic Engineering & Design Group), 3A, FDA (Food and Drug Administration), ASME-BPE and ATEX (directive 94/9/CE) hygiene standards.

The filling oils used (vegetable oil-Neobee[®], mineral oils) conform to FDA requirements.

The remote seal' flush construction enables excellent resistance to temperatures and overpressures while guaranteeing easy "Cleaning-in-Place" (CIP) and Sterilization-in-place (SIP) processes.

In addition to the process and hydrostatic level pressure measurements, Fuji Electric France's pressure transmitters enable the measurement of the inert gas layer, the filter dirt build-up, the filling pressures and the overpressures in clean rooms.

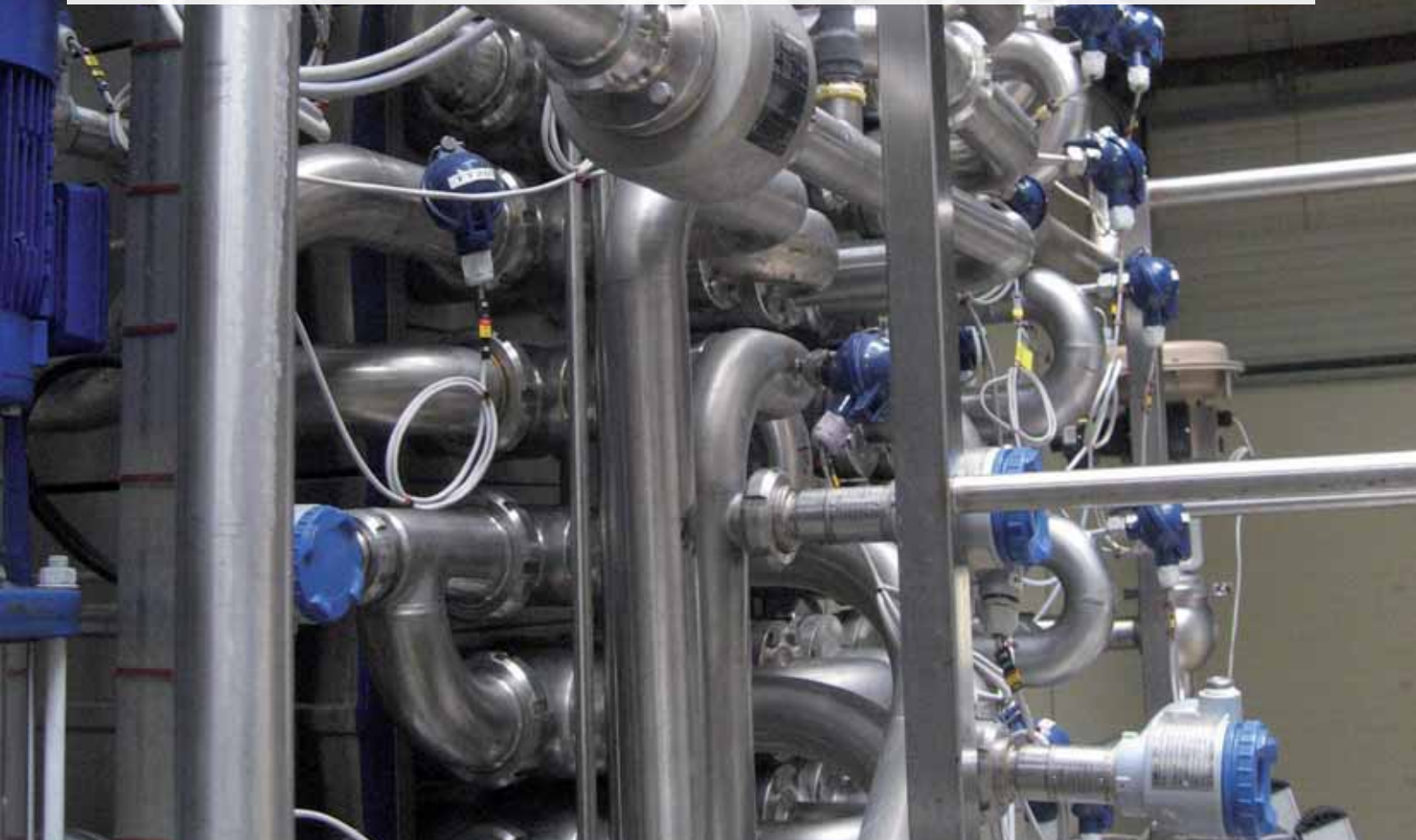

Transmitter/remote seals assembly with ferrule to be welded and remote seal according to DIN 11851 and DN50

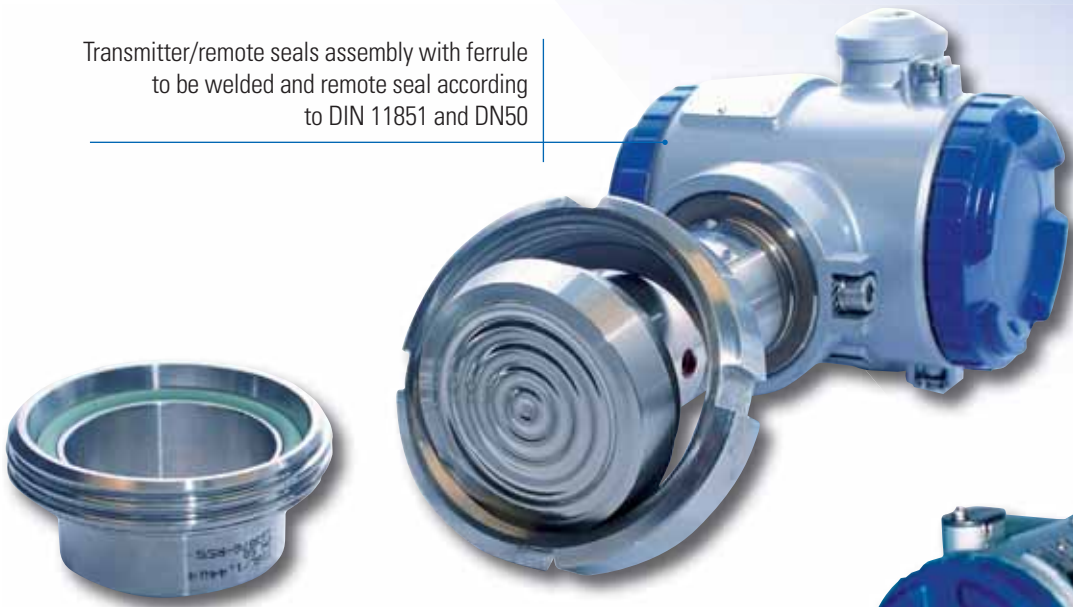

Inline relative pressure measurement for sterile installations for pure fluids in flow.

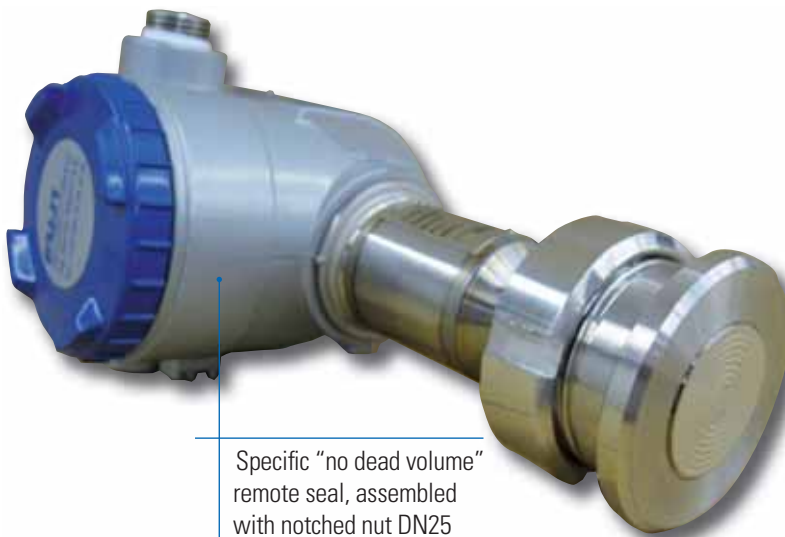

Specific "no dead volume" remote seal, assembled with notched nut DN25 according to DIN 11851.

Approvals



Remote seals & process connectors



Food & beverage connectors according to DIN 11851 and SMS



VARIVENT® connectors



DRD connectors



Tri-Clamp connectors

CHEMICAL APPLICATIONS

Pressure transmitters are present everywhere the customer demands precise and lasting measurements. The expertise of our R&D teams and the reliability of our equipment have enabled us to increase the performances and quality of our products in order to meet the numerous technical challenges of the chemical industry.

This industry applications (distillation towers, reactors, separators, etc.) are distinguished by very wide temperature and pressure ranges. Pressure transmitters and their remote seals are temperature-compensated in order to guarantee the precision and reliability of their measurements, regardless of the ambient or process conditions.

For the storage and procurement of the raw materials involved in the processes (tanks and buffer tanks, solvent, toxic fluid, ammonia, chlorine and other storage), Fuji Electric has a wide range of separator level transmitters able to withstand the harshest chemical attacks. The materials used (stainless steel, Hastelloy C, Tantalum, Monel, etc.) guarantee a long life for your appliances.

Safety is our priority; our pressure transmitters are certified for explosive zones and meet SIL safety rules.

Standard or "custom built" transmitters may be delivered within very short lead times and our teams are at your disposal for the maintenance of your appliances.

From measurement to process control, Fuji Electric France provides you with its know-how and expertise in industrial instrumentation to guarantee you the best solutions.



Flow measurement with integrated orifice in Hastelloy C and bases in PVDF for chemical resistance to Chlorine.



Relative pressure measurement on a urea application in the chemical industry with specific material certifications.



Level transmitter on closed tank, equipped with remote seals with gold coating for protection against corrosion.

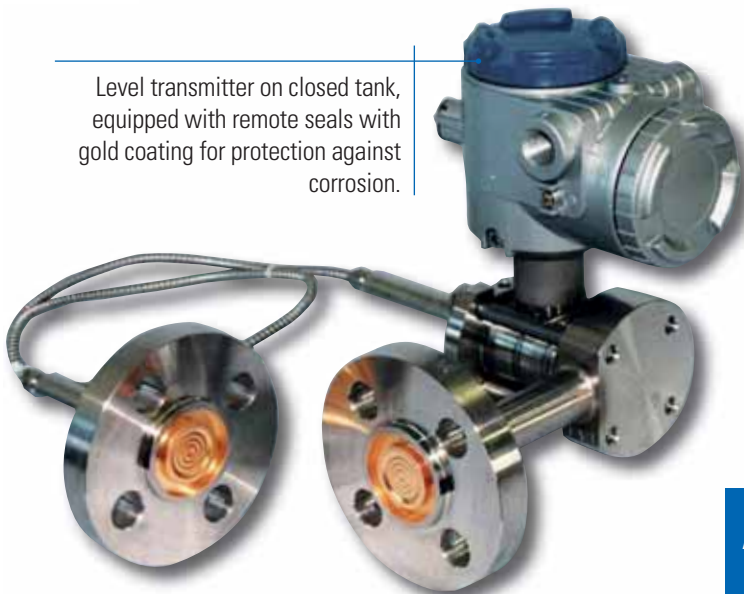

Differential pressure transmitter for level, density and interference measurement, mounted with 2 remote seals, contact parts PFA coated to remedy adhesion to fluid on the diaphragms.

Approvals



PAPER APPLICATIONS

Whatever your process condition (pressure, level or flow), Fuji Electric France pressure transmitters are now widely used in paper, cardboard or pulp manufacturing installations and guarantee productivity and availability for installations.

The exceptional measurement functions, combined with their compact size and their robustness make our pressure transmitters the ideal products for papermaking pump applications.

Their process connections position the membrane flush with the walls of the pipe or tank, eliminating clogging problems related to viscous fluids which have crystallising, polymerising or precipitating properties.

Specific remote seals enable them to withstand major pressure shocks and abrasion for level measurement in the pulpers during the old paper and pulp dissolving phases. The relative pressure transmitters are used during the fibre separation phases.

During the pulp implementation phases, the transmitters measure the level in the accumulation and drainage towers and in the constant part which acts as the link between the pulp preparation and the paper machine.

For applications on the paper and cardboard machines, the separator models are used to measure the pressure and level of the paper machine's head unit, and the vacuum on the press and sieve part.

Fuji Electric France transmitters work on the drying part for the cylinder steam pressure and rate measurements.



Relative or level pressure measurement on tank at atmosphere with flush diaphragm.



Remote seal with ceramic coating to protect the diaphragm against abrasion, often used in paper-making, the oil industry, waste water treatment, powder transport, etc.



Level transmitter with extension remote seal and specific length according to customer request.



Level transmitter on open tank equipped with a G2" remote seal and flush diaphragm (also available in 1" and 1.5" version).



Agréments



Remote seals & process connectors



M44 x 1.25 screw-in remote seal



1" – Flush remote seal



G1", G1 1/2 and G2" remote seal



Remote seal with ceramic coating

WATER & ENVIRONMENT APPLICATIONS

For applications in the waste water treatment and environmental domains, Fuji Electric France provides a range of transmitters for pressure, flow and level measurement adapted to aggressive and corrosive fluids.

To limit abrasion during purification or mud treatment with loaded water (suspended solids, scum), mountings with flush diaphragm screw-in remote seals are available.

For desalination plants, Fuji Electric France provides you with pressure transmitters with diaphragms and parts in contact with the fluid made from Hastelloy C, Monel or ceramic coating, as well as stainless steel units to avoid salt attacks.

For organic mud Wet Oxidation conversion processes, duplex separators and diaphragms coated with Gold and Rhodium avoid any risk of hydrogen infiltration and corrosion.

Thanks to their unique design, our pressure transmitters are extremely resistant to impact, the vibrations generated by displacement pumps and overpressure (knocking).

This range has the drinking water accreditations required for measurement appliances.

With Fuji Electric France, you can be sure of reliable and precise measurements whatever the usage conditions.





Standard differential pressure measurement for level, rate or filter dirt build-up measurement.



Relative pressure transmitter mounted on 2-valve manifold.

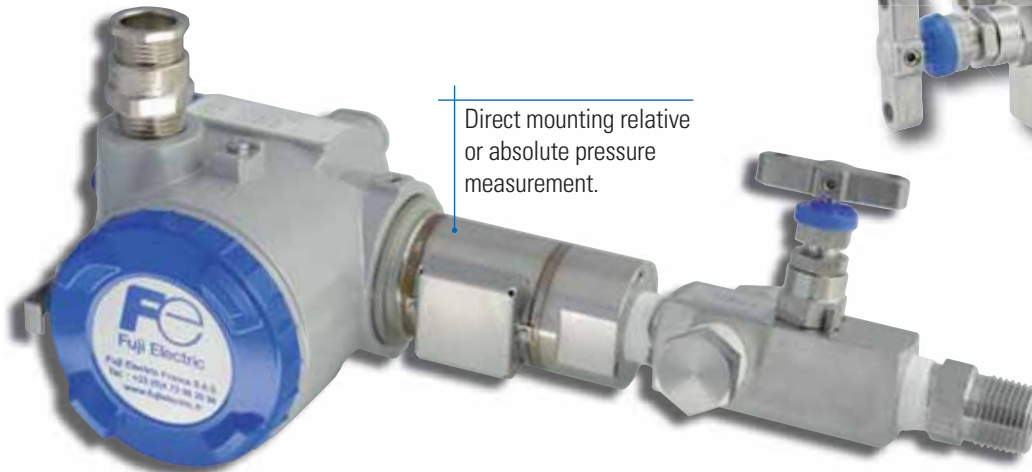

Direct mounting relative or absolute pressure measurement.

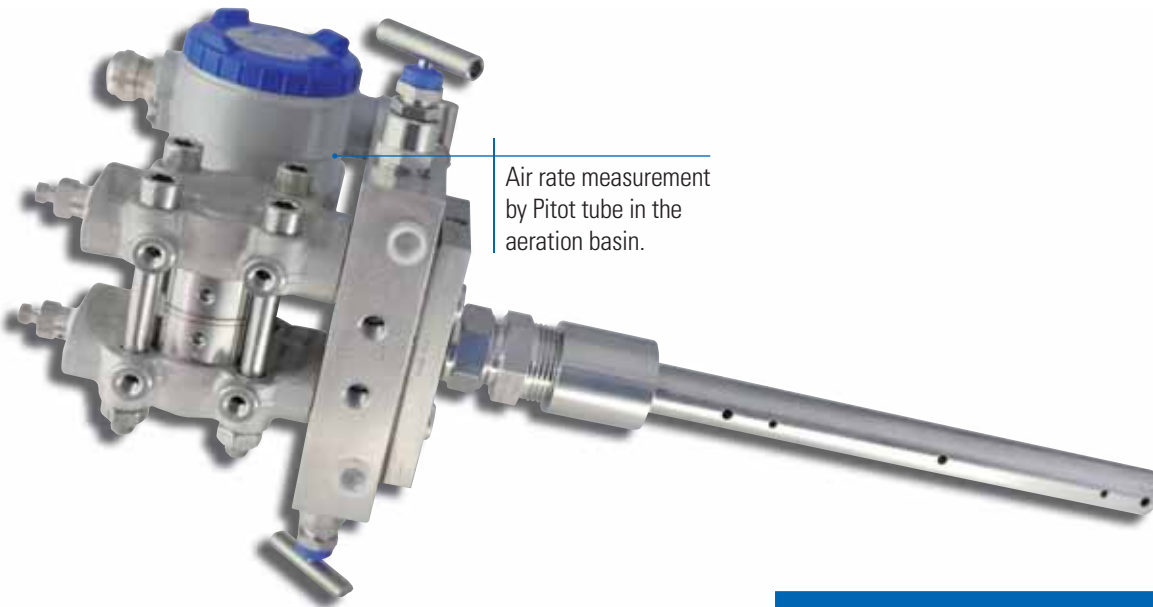

Air rate measurement by Pitot tube in the aeration basin.

Approvals



Remote seals & process connectors



Remote seal with gold/rhodium coating

VARIOUS PROCESS APPLICATIONS

Fuji Electric France studies its customers' specific requirements to propose a solution which is suited to their applications, taking account of the service conditions.

This is why we are constantly expanding the versions of our transmitters and specific remote seal(s) to provide the best response to your requirements.





1



2



3

Pressure or level transmitter with dismantling under load (ball valve to isolate the transmitter from the process).
Applications :
Sugar production, paper production and other continuous processes.



Pressure or level transmitter with cooling element for use at max. process temperatures of 230°C.
Applications :
Dairies, bitumen.

Disk-type remote seal pressure transmitter for highly abrasive processes.
Applications :
Concrete, drilling, mines and quarries.







Relative pressure transmitter with G1.5" connectors.
Application :
Aerospace.

Approvals





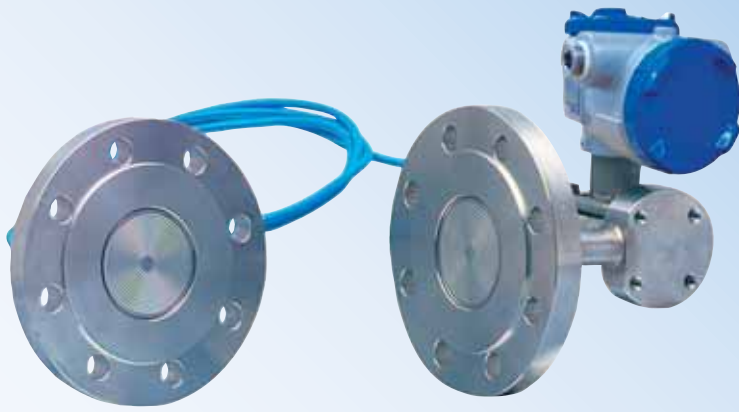

Technical Specifications

<i>Transmitters type</i>					
	<i>Differential pressure kPa (mbar)</i>	<i>Relative pressure kPa (bar)</i>	<i>Absolute pressure kPa (bar)</i>	<i>Direct mounting relative pressure kPa (bar)</i>	<i>Direct mounting absolute pressure kPa (bar)</i>
<i>Maximum span</i>	1 (10) 6 (60) 32 (320) 130 (1300) 500 (5000) 3000 (30000) 20000 (200000)	130 (1,3) 500 (5) 3000 (30) 10000 (100) 50000 (500)	16 (0,16) 130 (1,3) 500 (5) 3000 (30) 10000 (100)	130 (1,3) 500 (5) 3000 (30) 10000 (100)	130 (1,3) 500 (5) 3000 (30)
<i>Model</i>	FKC	FKG	FKA	FKP	FKH
<i>Datasheet reference</i>	EDSF6-134	EDSF5-92	EDSF5-91	EDSF5-98	EDSF5-97
<i>Standard rangeability</i>	100 : 1 depending of the span			16 : 1 depending of the span	
<i>Accuracy of adjusted span</i>	Up to $\pm 0.04\%$ / Standard $\pm 0.065\%$ (Others : please refer to the datasheets)			$\pm 0.1\%$	$\pm 0.2\%$
<i>Temperature limits</i>	-40 to +120°C (process) -40 to +85°C (ambient)			-40 to +100°C (process) -40 to +85°C (ambient)	
<i>Wetted parts material</i>	SS 316L Hastelloy C [®] Monel [®] Tantalum (Please refer to the datasheets for more details)			SS 316L	
<i>Output signal & power supply</i>	4-20 mA dc + Fuji and Hart [®] protocols / 10.5 à 45 Vdc (power supply)				
<i>Communication</i>	Fuji / Hart [®] protocols (standard) / Fieldbus Foundation H1 protocols (option)				
<i>Environmental protection</i>	IEC IP67 and NEMA 4X				
<i>Hazardous area certifications</i>	Flame proof areas and intrinsic safety (ATEX, FM, CSA, etc.) (Please refer to the datasheets for more details)				
<i>Available functions</i>	1/ Burnout according NAMUR NE43 recommendation 2/ Linearization function (14 points) to linearize the output signal				
<i>Options</i>	1/ Local analog or digital indicator, 2/ Arrestor (lightning protection), 3/ Stainless steel (SS 316) electronics housing, 4/ NACE requirements, 5/ High process temperature, vacuum service (for level and remote seal transmitters), 6/ Chlorine service, 7/ Diaphragm with gold or gold/ceramic coating for hydrogen applications, 8/ Stainless steel bolts and nuts, 9/ PTFE process cover gasket, 10/ Tag plate, 11/ Side vents				



<i>Remote seal(s)</i> <i>kPa (mbar)</i>	<i>Level</i> <i>kPa (mbar)</i>	<i>Direct mounting</i> <i>remote seal</i> <i>kPa (bar)</i>
Depending of transmitter version	32 (320) 130 (1300) 500 (5000)	130 (1,3) 500 (5) 3000 (30) 10000 (100)
<i>FKB/D/M</i>	<i>FKE</i>	<i>FKH/P</i>
EDSF6-05	EDSF7-68	EDSF6-06
100 : 1 depending of the span		16 : 1 depending of the span
±0.065% (differential and relative pressure), 0,2% (absolute pressure)	±0.165% (0,1% optional)	±0.1% or ±0.2%
-90 to +400°C (process) -40 to +85°C (ambient)	-40 to +150°C (process) -40 to +85°C (ambient)	-40 to +150°C (process) -40 to +85°C (ambient)
SS 316L Hastelloy C® Monel® Tantalum (Please refer to the datasheets for more details)		

Technical Specifications

				
Transmitters type	TR 22 - Gauge pressure TA 22 - Absolute pressure	TR 2 - Gauge pressure TA 2 - Absolute pressure	TR 1 - Gauge pressure TA 1 - Absolute pressure	GR - Gauge pressure GA - Absolute pressure
Sensing element	Flush ceramic cell	Thick enamelled strain gauge on ceramic		
Measurement range	Gauge range : -1 to 50 bar (24 ranges available) Absolute range : 0 to 50 bar abs. (15 ranges available)	Gauge range : -1 to 400 bar (30 ranges available) Absolute range : 0 to 25 bar abs. (13 ranges available)		Gauge range : -1 to 250 bar (29 ranges available) Absolute range : 0 to 25 bar abs. (11 ranges available)
Maximum span Overpressure	1,5 to 75 bar 3 to 75 bar	1,5 to 600 bar 3 to 600 bar		1,5 to 600 bar
Output signal	4 to 20 mA , 2 wires			
Power supply	12 to 28 Vdc (Protection against reverse polarity)			10 to 30 Vdc (Protection against reverse polarity)
Substituted values	Environ 3,7 mA or 25 to 27 mA (In case of strain gauge breaking)			
Zero/span adjustment	± 3% (as option rangeability of 50 to 100% of FS)			
Load	$R (\Omega) = (U_{alim} - 12 V) / 0.02 A$			$R (\Omega) = (U_{alim} - 10 V) / 0.02 A$
Max global error	≤ 0.2% FS (at 25°C) Linearity + Hysteresis + Repeatability	≤ 0.2% FS (at 25°C) ≤ 0.4% FS (at 25°C) (see datasheets) Linearity + Hysteresis + Repeatability		≤ 0.5% FS (at 25°C) ≤ 1% FS (at 25°C) (See datasheet) Linearity + Hysteresis + Repeatability
Temperature drift	± 0,03% / °C FS (Between 0 and 50°C)			± 0.03% / °C FS typical ± 0.06% / °C FS max
Ambient temperature	-20 to +100°C (135°C max for short period)	-20 to +70°C		-30 to +80°C
Process temperature	-20 to +70°C			
Storage temperature	-40 to +80°C	-40 to +80°C		
Protection	IP66		IP 65 (connector output) IP 66 and IP 68 (cable output)	IP 65 (connector output) IP 67 (cable output)
Connection	Process connection : SS 316L : 1"GM, 1"1/2 or 2"CLAMP, 1"1/2 or 2"SMS Electrical connection : On internal terminals and metallic cable glands ISO12 (Ø4-8 mm)	Process connection : SS 316L : 1/2"GM, 1/4"GM or 1/2"NPTM Electrical connection : On internal terminals and metallic cable glands ISO12 (Ø4-8 mm)	Process connection : SS 316L : 1/2"GM, 1/4"GM , 1/2"NPTM, Electrical connection : ISO4400 / DIN43650 Connectors Cable output 2 m length M12 connection (4 pins)	
Housing	Stainless steel 316L			Stainless steel
Wetted parts	SS 316L + ceramic + Viton o'ring seal (Others : see datasheet)		SS 316L + ceramic + FKM seal (Others : see datasheets)	
Certifications / Conformities	<ul style="list-style-type: none"> • ATEX version (option) : Intrinsic safety Ex ia IIC T6 Ga (-30 < T°amb. < 55°C) Ex ia IIC T5 Ga (-30 < T°amb. < 70°C) Ex ia IIIC T80°C Da (-30 < T°amb. < 55°C) Ex ia IIIC T95°C Da (-30 < T°amb < 70°C) • Group - Category : II - 1 GD and IM1 (GR / GA) 			

Our range of Fuji Electric products

Pressure

- Differential pressure (with remote seals)
- Relative or absolute pressure (with remote seal)



Flow

- Ultrasonic
- Electromagnetic
- Vortex



Energy metering

- Liquid
- Steam
- Gas
- Thermal
- Electricity



Gas analysis

- Zircon sensor oxygen analyzers
- Non dispersive infrared multigas analyzers
- In-situ laser analyzers
- Continuous pollutant analysis system (CEMs)



Controllers

- Temperature control
- Process control



Recorders

- Paper
- Video



Temperature

- Thermocouples
- Displays
- Thermo-resistances
- Signal converters



Services and Solutions

- Design
- Development
- Production





Printed : 11/2016 - FEF

Fuji Electric

FUJI ELECTRIC FRANCE S.A.S.

46, rue Georges Besse

ZI du Brézet - 63039 Clermont-Ferrand Cedex 2 - France

Tel. France 04 73 98 26 98 - Fax. 04 73 98 26 99

Tel. international 33 4 73 98 26 98 - Fax. 33 4 73 98 26 99

Email : sales.dpt@fujielectric.fr

Web : www.fujielectric.fr

*Fuji Electric cannot be held responsible for any errors in the catalogues, brochures or other printed media. Fuji Electric reserves the right to modify its products without notice. This also applies to the products ordered, if the modifications do not alter the specifications substantially. The registered marks and names which appear in this document are the property of their respective depositors.
All rights reserved.*



PL 16 (Palokorvenkatu 2), 04261 Kerava • puh. 010 417 4500 • hyxo@hyxo.fi • www.hyxo.fi