

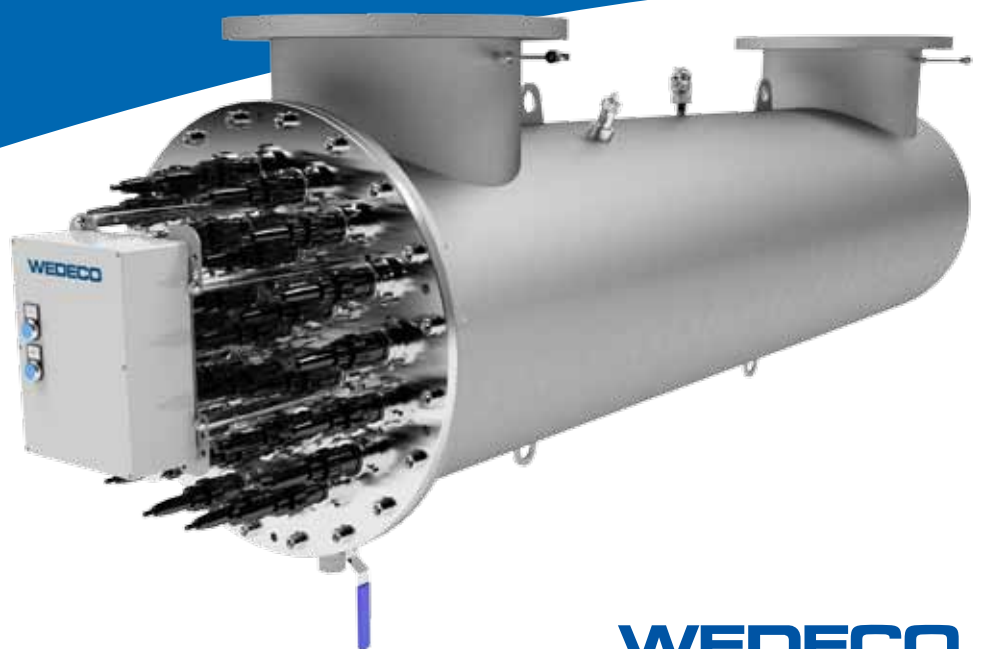

# WEDECO LBX Series

THE IDEAL UV SOLUTION WHEN WASTEWATER IS UNDER PRESSURE



**WEDECO**  
a xylem brand

# Certified to meet industry and national standards. Customized to meet yours.

The WEDECO LBX Series is a thousand times proven, energy efficient solution for the disinfection of pressurized wastewater, surface water, process water, and other low UV transmittance liquids.

## Validated performance for applications from water to water reuse

LBX systems have been extensively tested to meet the U.S. Environmental Protection Agency's UV Disinfection Guidance Manual (USEPA's UVDGM 2006) and the National Water Research Institute (NWRI) guidelines, including the most stringent California Title-22 Water Reuse standards. The extensive validation envelope allows for proven disinfection performance over a wide range of UV transmittance (UVT) and a variety of target organisms including Adenovirus.

## Highest efficiency and adaptability for various municipal and industrial treatment schemes

For improved economy and maximum sustainability LBX units employ WEDECO's low-pressure, high-output (LoHi) amalgam ECORAY® UV lamps. With numerous sizes for a wide range of flow rates and extensive options including alternative flange connectors and reactor shapes, cabinet types, various control modes, chemical free wiping system, and SCADA communications, the LBX Series is easily customizable to match specific site requirements.

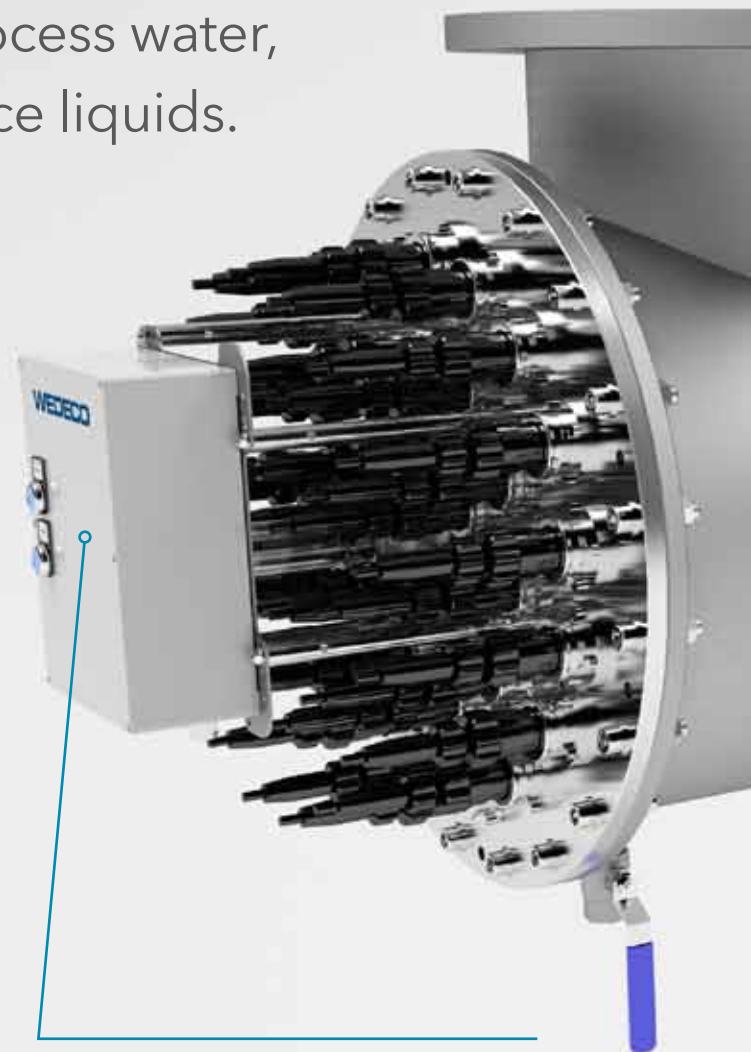

### Reduce Costs

The automatic wiping system maintains maximum sleeve transmittance resulting in peak efficiency. By keeping the sleeves clean, the system uses less energy and lowers operational costs.

### Save Energy

UV sensor-based OptiDose™ closed-loop UV control allows energy savings up to 20% by adjusting the output to match water quality and flow in real-time. This avoids over dosage and reduces overall operating cost without compromising disinfection performance.



### Simplify Operation

The unique EcoTouch controller unifies all sensor signals, alarms, SCADA connectivity, and OptiDose closed loop control to maximize operator usability.

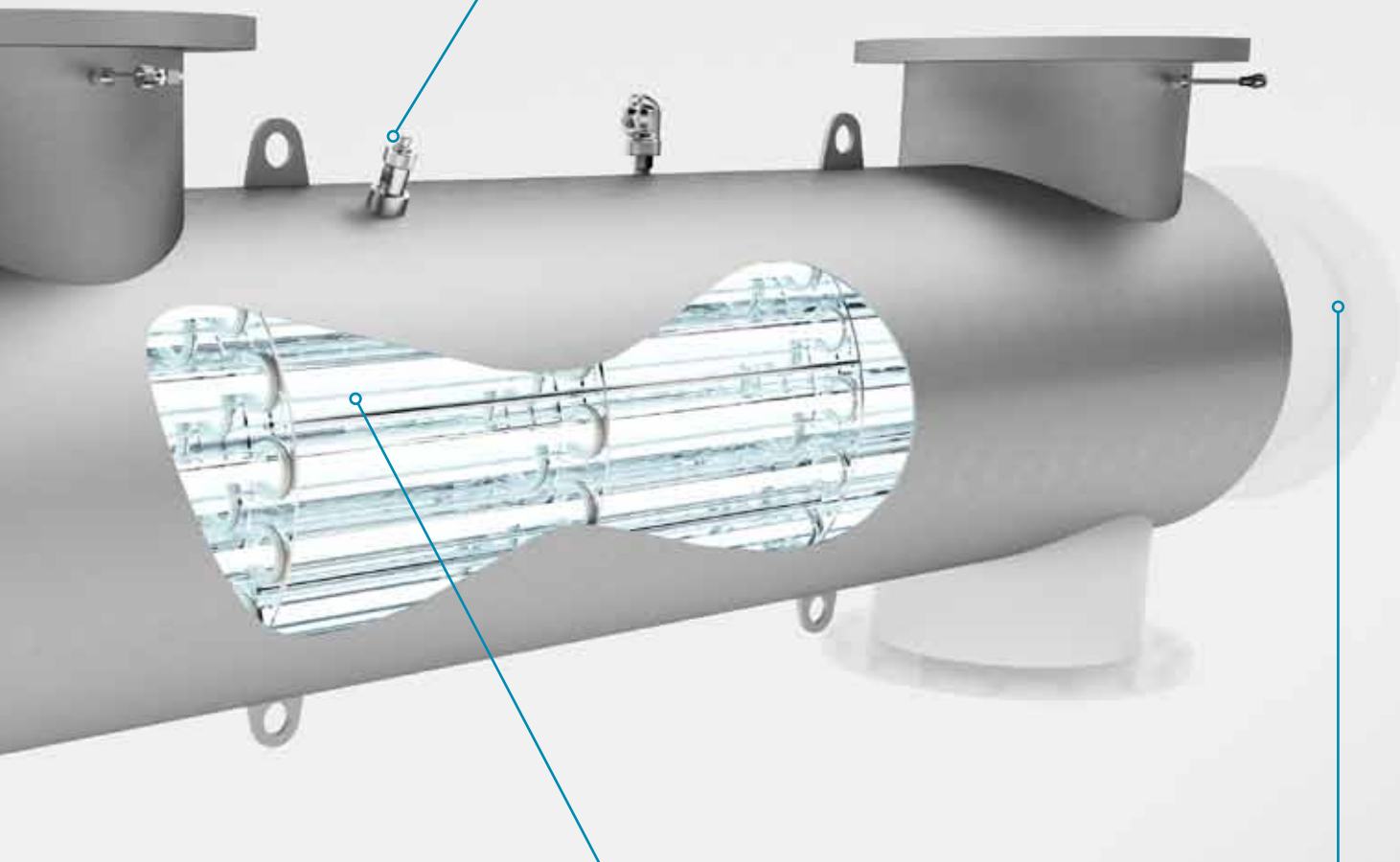

### Improve Performance

Exclusive ECORAY Technology perfectly matches UV lamps and ballasts to deliver the highest efficiency, longer lamp life, shorter warm-up time and excellent dimming mode properties to do the job. More stable and sustainable by reduced mercury content, ECORAY lamps are an environmentally friendly choice that can help reduce your carbon footprint.

### Maximize Flexibility

Alternative shapes and flanges maximize the flexibility to fit in site-specific arrangements. L shape units also feature the patented OptiCone flow diverter that optimizes hydraulics no matter of inlet piping conditions.

# WEDECO LBX Series FLEXIBLE SOLUTIONS TO FIT YOUR SPECIFIC NEEDS

LBX Series - System Specification														
Model #	3	10	20	33	50	90	120	200	400	550	850	1000	1500	
Standards	CE					CE, UL, cUL								
UV Transmittance	20 - 98													
Flow Rate (m <sup>3</sup> /h / GPM)**	2.6 / 11	10.2 / 45	21.7 / 96	29.3 / 129	45.1 / 199	83 / 365	127 / 559	216 / 951	347 / 1528	536 / 2360	717 / 3157	911 / 4011	1346 / 5926	
Bioassay Tested	N/A					Yes *	N/A		Yes *	N/A		Yes *		
UV Lamps and Monitoring System														
Power Per Lamp (W) Approx.	80					315								
Number of UV Lamps	1	3	6	8	12	4	6	10	16	24	32	40	60	
Lamp Certification	N/A					3 <sup>rd</sup> Party on Aging and UV-C Output								
UV Intensity Monitoring	Germicidal, ÖNORM Compliant													
Dose Pacing (Variable Power)	N/A					Optional								
Individual Lamp Monitoring	Yes					Yes								
UV Reactor														
Protection Class	IP 65					IP 65 / NEMA 4X								
Automatic Wiping System	N/A	Optional												
Reactor Material	Stainless Steel 1.4404 / 1.4435 (ASTM 316L)													
Flange Sizes	R 1 ½"	DN 50	DN 80	DN 100	DN 150 / ANSI 6"	DN 200 / ANSI 8"	DN 250 / ANSI 10"	DN 300 / ANSI 12"	DN 400 / ANSI 16"	DN 500 / ANSI 20"				
Reactor Shape	U or Z										L	U or Z	L	
Reactor Length (MM / Inch) Approx.	930 / 37					1530 / 60		1540 / 61			2400 / 95			
Operating Pressure (Bar/PSI), Max.	10 / 145	16 / 232			16 / 232	10 / 145								
UV System Control Cabinet														
Controller	Microprocessor					EcoTouch or PLC								
Common Outputs	System Status, Lamp Status, Alarm Messages, Process Values													
Bus Communication	N/A					Yes								
Protection Class	IP 54					IP 54 / cUL Type 12 (4X Optional)								
Supply Voltage (V / V / Hz)	230 V / 50 - 60 Hz (TN-S-net, TN-C-net)					CE: 400/230 +/- 10%, 50 Hz (TN-S Net) cUL: 480/277 +/- 10%, 60 Hz (5 Wire WYE; L1,L2,L3,N,GND)								
Power Consumption (kW) Approx.	0.1	0.34	0.6	0.76	1.1	1.72	2.38	3.7	5.69	8.33	11.19	13.84	20.57	

\* Compliant with NWRI and UVDGM protocol

\*\* UV Dose according to the "point source summation" method: 40 mJ/cm<sup>2</sup>; UVT = 65% per 1 cm at the end of the lamp lifetime.



WEDECO is a brand of Xylem, whose 12,000 employees are addressing the most complex issues in the global water market.

[www.xylem.com](http://www.xylem.com)

Xylem Water Solutions Herford GmbH  
 Boschstr. 4 - 14  
 32051 Herford, Germany  
 Phone +49 5221 930 0  
 Fax +49 5221 930 222  
[www.wedeco.com](http://www.wedeco.com)