

LZX337
LZX660
LZX661
LZY630.00.10000
LZY630.00.11000
LZY630.00.12000

DOC273.99.90204/6A

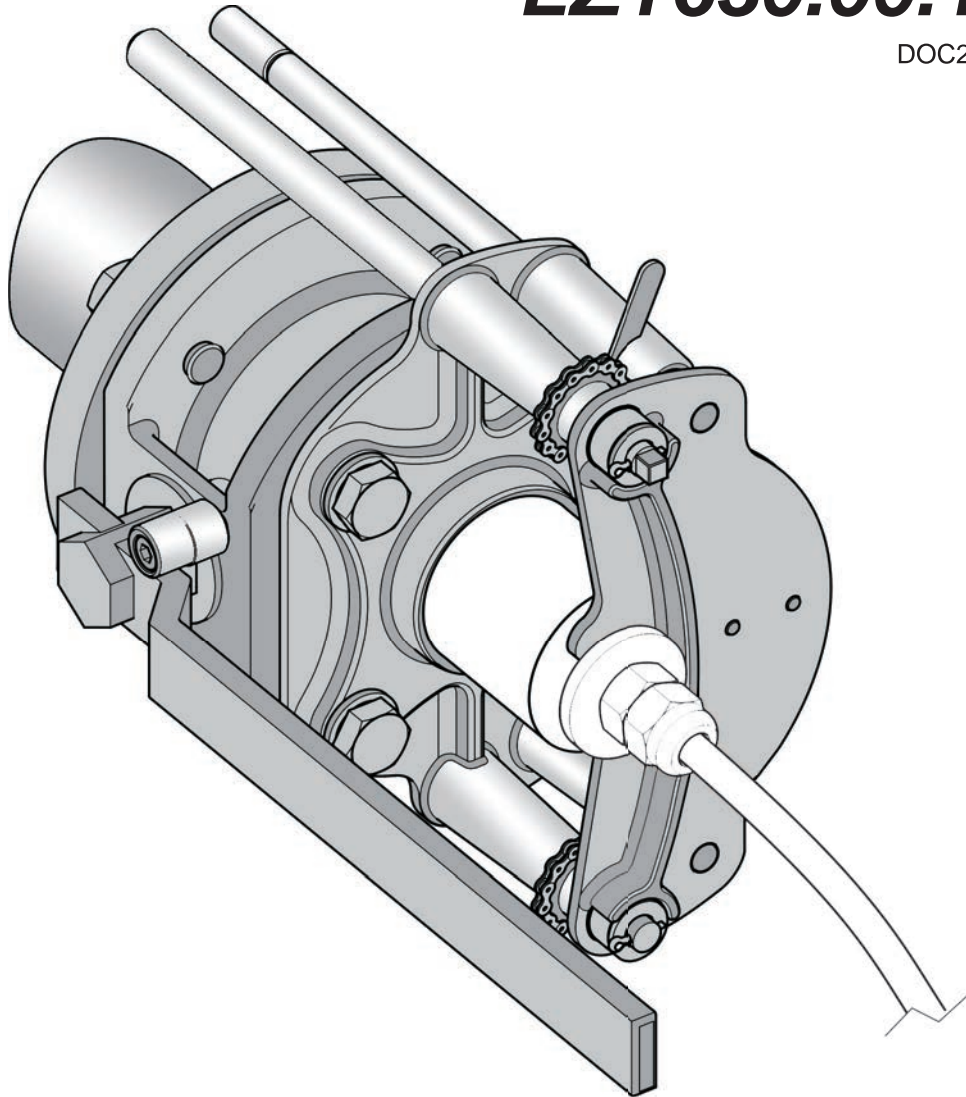

gwarancji i wykluczają wszelką odpowiedzialność producenta. Nieprzestrzeganie tych instrukcji lub używanie produktu do celów innych niż wynika z opisu jego przeznaczenia, może być przyczyną poważnych wypadków z udziałem użytkownika i/lub uszkodzenia sprzętu. Wymagane prace spawalnicze muszą być wykonane zgodnie z normą DIN / EN 287 przez wykwalifikowany personel lub przez firmy pośredniczące zgodnie z EN3834-2.

PT Antes de instalar/montar o produto, leia atentamente as instruções de instalação e siga-as durante a instalação. A instalação deve ser efectuada por um profissional qualificado em conformidade com todas as regulamentações locais de segurança. Escolha cuidadosamente o local de instalação de modo a assegurar uma operação e instalação com segurança. Este produto foi concebido apenas para segurar/fixar sensores/produzidos para medições da HACH/HACH LANGE. Qualquer outro tipo de utilização pode implicar riscos para o utilizador. O trabalho de manutenção e reparação deve ser efectuado única e exclusivamente pelo departamento de assistência ao cliente devidamente autorizado. Apenas podem ser utilizados acessórios e peças de substituição originais recomendados pelo fabricante. Qualquer alteração feita ao produto anula qualquer responsabilidade da nossa parte. O não cumprimento das instruções ou a utilização do produto para outros fins que não aqueles para que o produto foi concebido pode resultar em ferimentos graves e/ou danos no equipamento. O trabalho de soldadura exigido deverá ser executado exclusivamente por soldadores qualificados de acordo com a norma DIN / EN 287, ou por empreiteiros em conformidade com a norma EN 3834-2.

RO Înainte de instalarea/montarea produsului, citiți cu atenție toate instrucțiunile de instalare și urmați instrucțiunile în timpul instalării. Instalarea trebuie realizată de un expert calificat în conformitate cu toate reglementările locale pentru siguranță. Aveți grijă să alegeți o locație de instalare care să asigure instalarea în siguranță. Produsul este destinat exclusiv pentru menținerea/atașarea senzorilor/produșelor de măsurare HACH/HACH LANGE. Utilizarea în alte scopuri poate implica riscuri pentru utilizator. Întreținerea și lucrările de reparație trebuie realizate exclusiv de departamentul de service autorizat pentru clienți. Pot fi utilizate numai piesele de schimb și accesoriile originale recomandate de producător. Orice modificare adusă produsului va duce la anularea oricărei răspunderi. Nerespectarea acestor instrucțiuni sau utilizarea produsului în alte scopuri decât în cele destinate pot duce la accidente grave pentru utilizator și/sau defectarea echipamentului. Lucrările de sudură necesare trebuie să fie efectuate exclusiv de sudori calificați în conformitate cu DIN / EN 287, sau de contractori în conformitate cu EN 3834-2.

RU Перед установкой/монтажом изделия необходимо внимательно прочитать инструкции по установке и строго следовать им во время выполнения работ. Установка должна быть выполнена квалифицированным специалистом с соблюдением действующих правил по технике безопасности. Выбирая место для установки, необходимо учитывать требования по безопасности при монтаже и эксплуатации изделий. Данное изделие предназначено только для крепления измерительных датчиков/приборов компании HACH/HACH LANGE. Любое другое применение может представлять опасность для пользователя. Работы по ремонту и техобслуживанию должны выполняться исключительно специалистами уполномоченной сервисной организации. С изделием могут использоваться только запчасти и принадлежности, рекомендуемые изготовителем. Любые изменения, внесенные в конструкцию изделия, приведут к отмене гарантии поставщика. Несоблюдение требований инструкции или использование изделия не по назначению могут стать причиной серьезных травм для людей и/или повреждения оборудования. Необходимые сварочные работы должны проводиться только сварщиками, квалифицированными в соответствии с DIN / EN 287, или подрядчиками в соответствии с DIN 3834-2.

SK Pred inštaláciou/upevnením produktu si pozorne prečítajte všetky pokyny k inštalácii a počas inštalácie ich dodržujte. Inštaláciu musí vykonať kvalifikovaný expert v súlade so všetkými miestnymi bezpečnostnými nariadeniami. Uistite sa, že si vyberiete miesto inštalácie, ktoré zaručí bezpečnú inštaláciu a prevádzku. Produkt je určený výlučne pre uchytenie/upevnenie meracích snímačov/produktov HACH/HACH LANGE. Akékoľvek iné použitie môže zahŕňať riziká pre používateľa. Údržbu a opravy by malo vykonávať výlučne autorizované oddelenie služieb pre zákazníkov. Môžu sa použiť len originálne náhradné diely a príslušenstvo, ktoré odporúča výrobca. Akékoľvek zmeny vykonané na produkte spôsobia neplatnosť všetkej zodpovednosti. Nedodržanie týchto pokynov alebo používanie produktu na iný než určený účel môže spôsobiť vážne zranenie používateľa alebo poškodenie zariadenia. Požadované zváračské práce musia byť vykonané výhradne v súlade s DIN/EN 287 kvalifikovanými zvaračmi, alebo dodávateľmi v súlade s EN 3834-2.

SL Pred namestitvijo/postavitvijo izdelka natančno preberite vsa navodila za namestitev in jih med nameščanjem upoštevajte. Namestitev mora izvesti usposobljen strokovnjak v skladu z vsemi lokalnimi varnostnimi predpisi. Za namestitev izberite mesto, ki zagotavlja varno namestitev in uporabo. Izdelek je namenjen izključno za namestitev/pritrđitev merilnih senzorjev/ izdelkov HACH/HACH LANGE. Vsakršna drugačna uporaba lahko predstavlja nevarnost za uporabnika. Vzdrževanje in popravilo lahko izvaja izključno osebje pooblaščenega servisnega oddelka. Uporabljajte lahko samo originalne nadomestne dele in dodatno opremo, ki jih priporoča proizvajalec. Spremembe izdelka razveljavijo vsakršno odgovornost. Če teh navodil ne upoštevate ali izdelek uporabljate v neprimeren namen, lahko pride do hudih poškodb uporabnika in/ ali poškodovanja opreme. Zahtevana dela varenja lahko izvajajo izključno usposobljeni varilci v skladu z DIN/EN 287 ali izvajalci v skladu z EN 3834-2.







SR Pre instalacije/montaže uređaja pažljivo pročitajte sva uputstva za montažu i pratite ih tokom postupka montaže. Instalaciju mora provesti kvalifikovani stručnjak u skladu sa lokalnim propisima o bezbednosti. Brižljivo odaberite mesto instalacije na kom će se montaža uređaja i korišćenje odvijati u bezbednim uslovima. Uređaj je namenjen isključivo za držanje/pričvršćivanje HACH/HACH LANGE mernih senzora/uređaja. Upotreba uređaja u druge svrhe može da predstavlja rizik po korisnika. Održavanje i opravke sme da provodi isključivo ovlašćeni serviser. Kod zamene i opravaka smeju da se koriste samo originalni rezervni i dodatni delovi koje je preporučio proizvođač. Bilo kakve izmene izvršene na uređaju poništavaju njegovu pouzdatnost. Nepriđržavanje uputstava ili upotreba uređaja u svrhe za koje nije namenjen mogu dovesti do ozbiljnih povreda ljudi koji ga koriste i/ili štete na opremi. Neophodni radovi zavarivanja treba da budu izvršeni od strane zavarivača u skladu sa DIN / EN 287 ili od ugovorenog izvođača radova u skladu sa EN 3834-2.

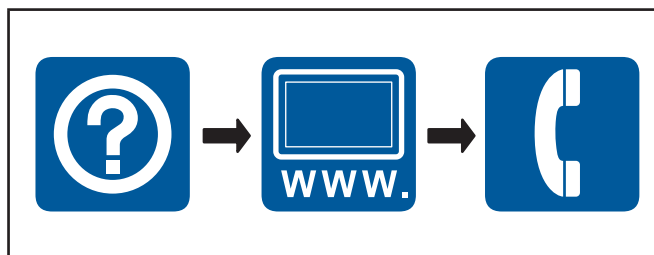
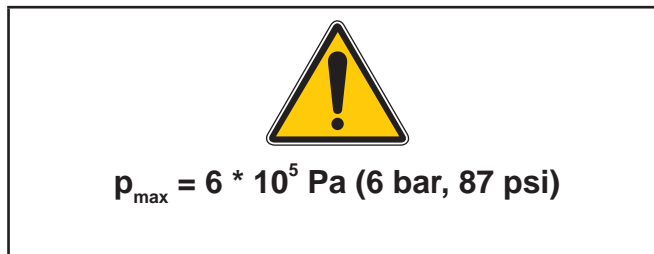
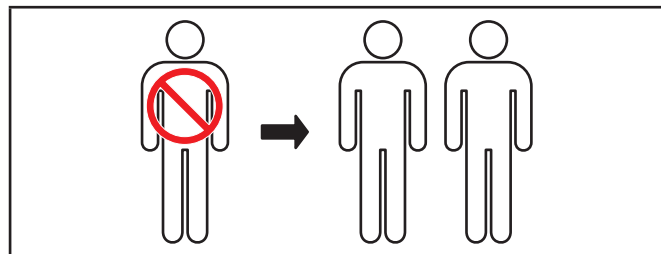
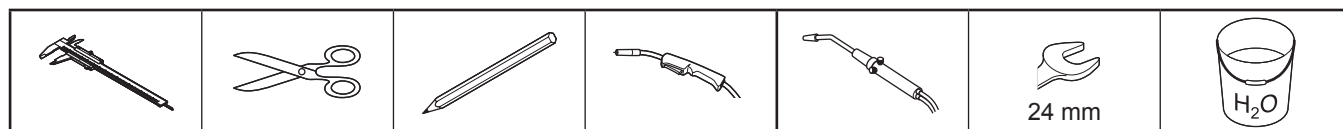



SV Läs alla installationsanvisningar noggrant innan du installerar/monterar produkten och följ anvisningarna under installationen. Installationen måste utföras av en kvalificerad expert i enlighet med alla lokala säkerhetsföreskrifter. Se till att välja en installationsplats som garanterar säker installation och drift. Produkten är endast ämnad för att hålla/fästa mätsensorer/-produkter från HACH/HACH LANGE. Annan användning kan medföra risker för användaren. Underhålls- och reparationsarbeten ska utföras av den auktoriserade kundserviceavdelningen. Endast originalreservdelar och -tillbehör som rekommenderas av tillverkaren ska användas. Om någon ändring görs på produkten upphävs tillverkarens ansvar. Det kan det medföra allvarliga skador för användaren eller skador på utrustningen om du inte följer anvisningarna eller om du använder produkten i installationer den inte är avsedd för. Svetsarbeten skall utföras av svetsare kvalificerade enligt DIN/EN 287, eller av entreprenör enligt EN3834-2.





TR Ürünün montajını yapmadan önce, tüm montaj talimatlarını dikkatlice okuyun ve kurulum sırasında talimatları mutlaka takip edin. Montaj, kalifiye bir uzman tarafından tüm yerel güvenli düzenlemelerine uygun şekilde yapılmalıdır. Ürünü, montaj ve kullanım güvenli olacağı bir yere monte edin. Ürün sadece HACH/HACH LANGE ölçüm sensörlerini/ ürünlerini, tutmak/takmak için tasarlanmıştır. Başka amaçlarla kullanılması, kullanıcı için tehlikeler doğurabilir. Bakım ve onarım sadece yetkili müşteri hizmetleridepartmanı tarafından gerçekleştirilmelidir. Sadece üretici tarafından önerilen orijinal yedek parça ve aksesuarlar kullanılmalıdır. Ürüne yapılan her türlü değişikilik, tüm sorumluluğu ortadan kaldırır. Bu talimatlara uyulmaması veya ürünün üretim amacından başka bir amaçla kullanılması sonucunda kullanıcı ciddi şekilde yaralanabilir ve/veya ürün zarar görebilir. Gerekli kaynak işi yalnızca kalifiye kaynakçılar tarafından DIN / EN 287'ye göre yapılmalıdır, veya müteahhitler tarafından EN 3834-2'ye göre yapılmalıdır.







ZH 在安装/固定产品之前, 请仔细阅读所有安装说明, 并在安装过程中遵守这些说明。必须由合格的专家完成安装, 并遵守当地的所有安全法规。仔细选择安装地点, 确保安全地安装和操作。本产品只能用于固定/连接 HACH/HACH LANGE 测量传感器/产品。用于其他用途可能会给用户带来危险。维护和修理工作应由经授权的客户服务部门完成。只能使用正宗替换件和制造商推荐的附件。对本产品进行任何更改均可能导致所有担保失效。不遵守这些说明, 或者将本产品用于其它用途, 可能会对用户造成严重伤害和/或设备损坏。所需的焊接工作必须要根据 DIN/EN 287, 由合格的焊接工人单独执行, 或者根据 EN 3834-2 由承包人执行。



























 SOLITAX inline sc LZX337	A1		A2	LZY441	A3	M16x45mm A4 ISO4017	A4	LZY462	A5	DOC273. 99. 03911	A6	LZV678
	1x		1x		4x		1x		1x		1x	

 SS 316Ti/ 1.4571 DN65/PN16 DIN 2633 LZX660	B1	DN65	B2	DOC273. 99. 03911	B3	DN65						
	1x		1x		1x							

 C-steel / 1.0037 DN65/PN16 DIN 2633 LZX661	B1	DN65	B2	DOC273. 99. 03911	B3	DN65						
	1x		1x		1x							

 TSS inline sc LZY630.00.12000	A1		A2	LZY441	A3	M16x45mm A4 ISO4017	A4	LZY462	A5	DOC273. 99. 03911	A6	LZV678
	1x		1x		4x		1x		1x		1x	

 TSS inline sc LZY630.00.10000												
 LZY630.00.12000	A1		A2	LZY441	A3	M16x45mm A4 ISO4017	A4	LZY462	A5	DOC273. 99. 03911	A6	LZV678
	1x		1x		4x		1x		1x		1x	
 SS 316Ti/ 1.4571 DN65/PN16 DIN 2633 LZX660	B1	DN65	B2	DOC273. 99. 03911	B3	DN65						
	1x		1x		1x							

 TSS inline sc LZY630.00.11000												
 LZY630.00.12000	A1		A2	LZY441	A3	M16x45mm A4 ISO4017	A4	LZY462	A5	DOC273. 99. 03911	A6	LZV678
	1x		1x		4x		1x		1x		1x	
 C-steel / 1.0037 DN65/PN16 DIN 2633 LZX661	B1	DN65	B2	DOC273. 99. 03911	B3	DN65						
	1x		1x		1x							

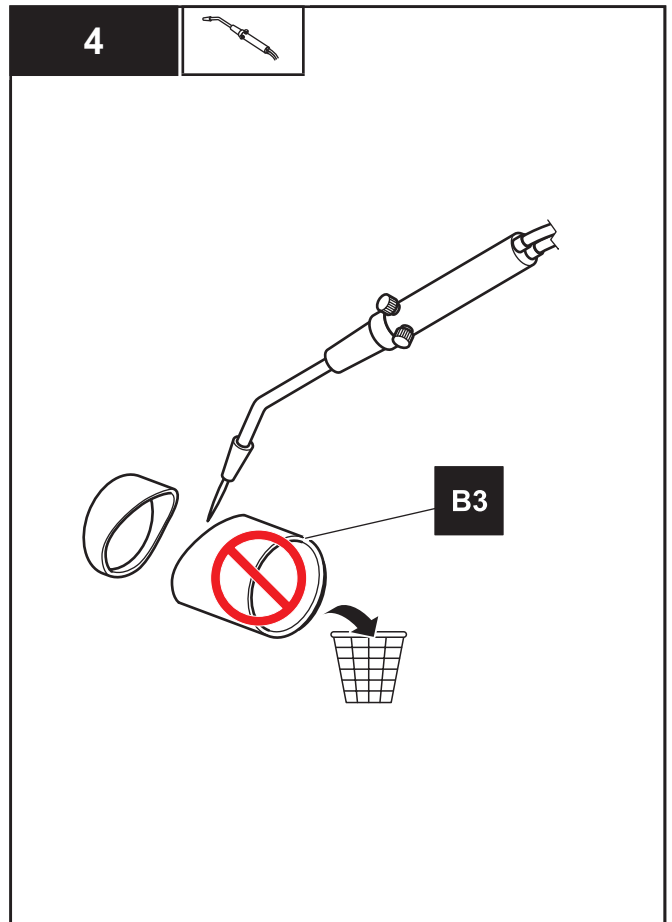
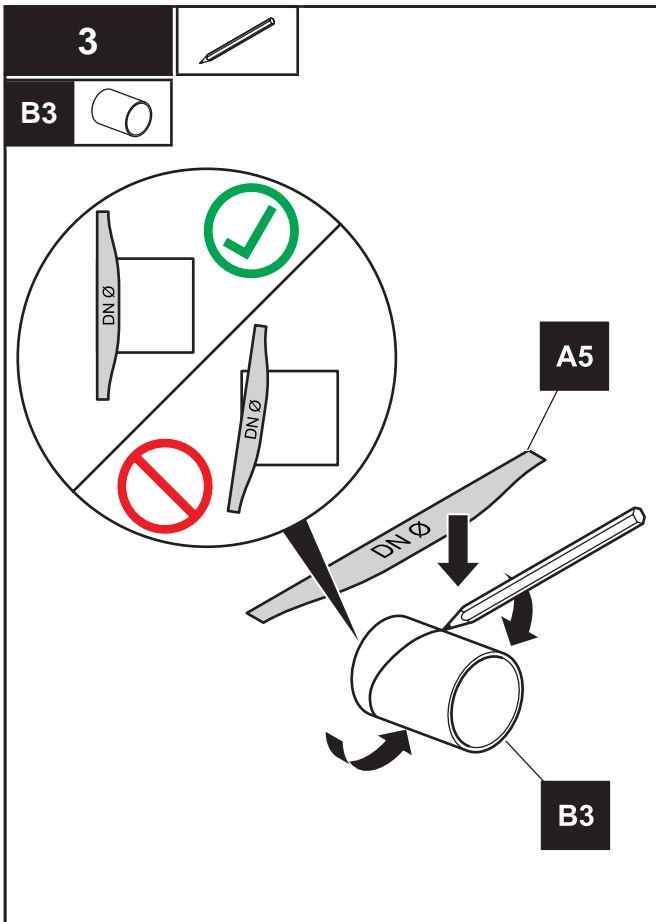
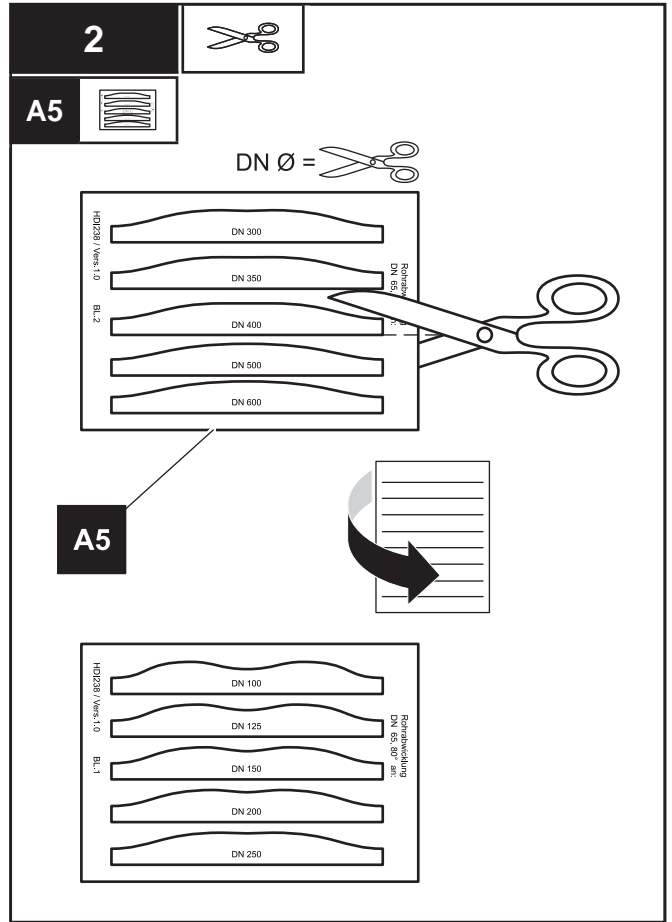
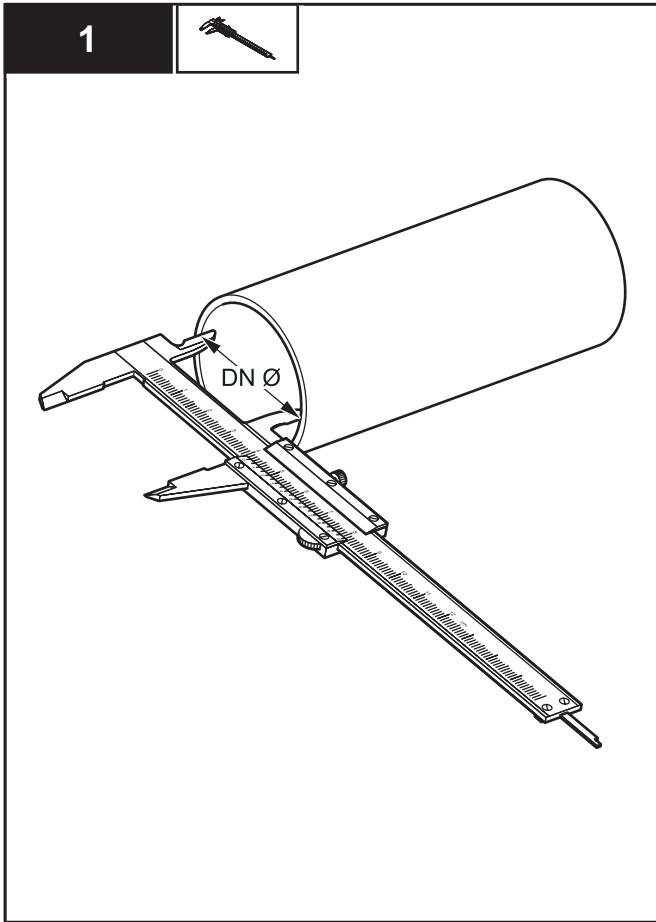

5

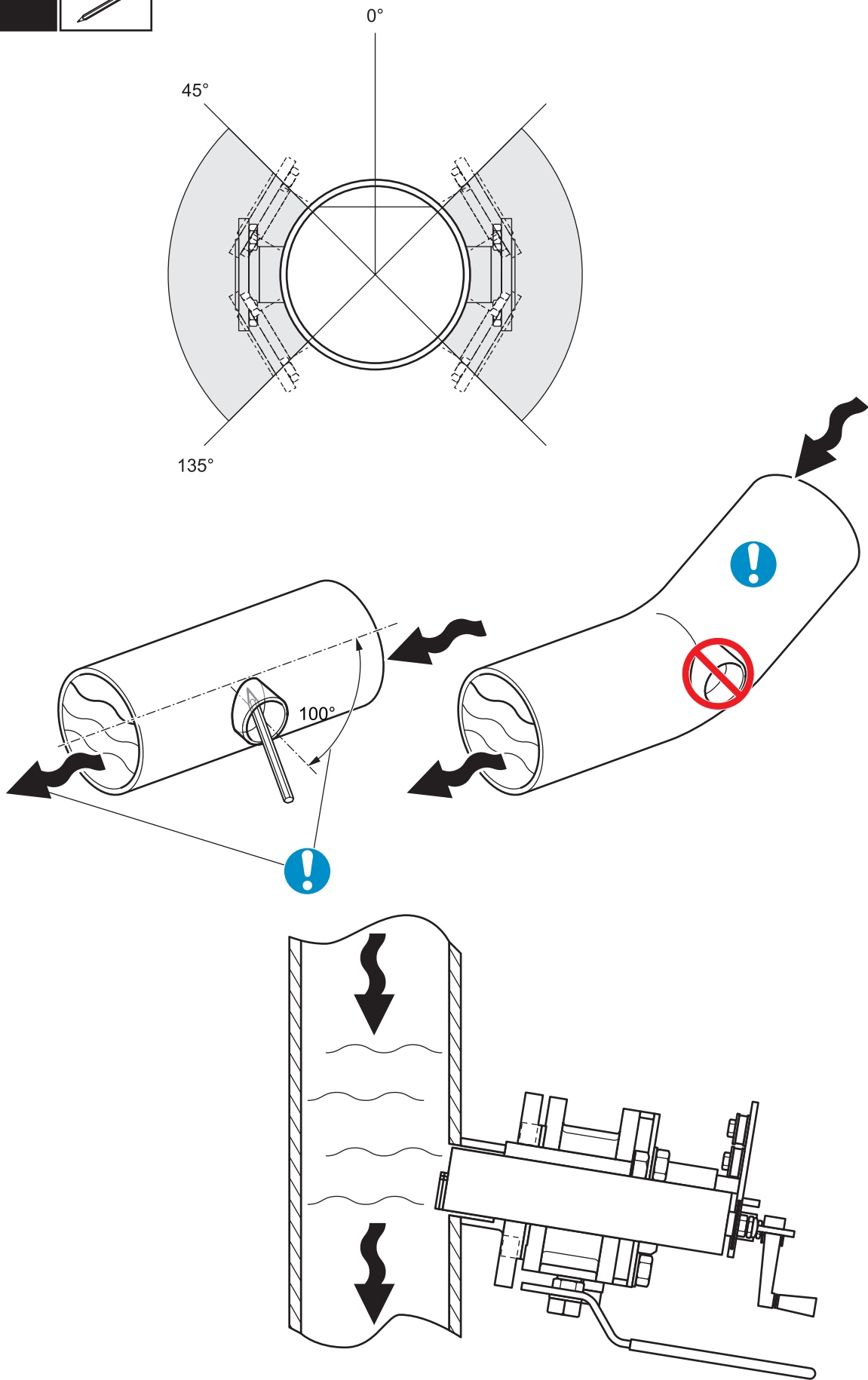

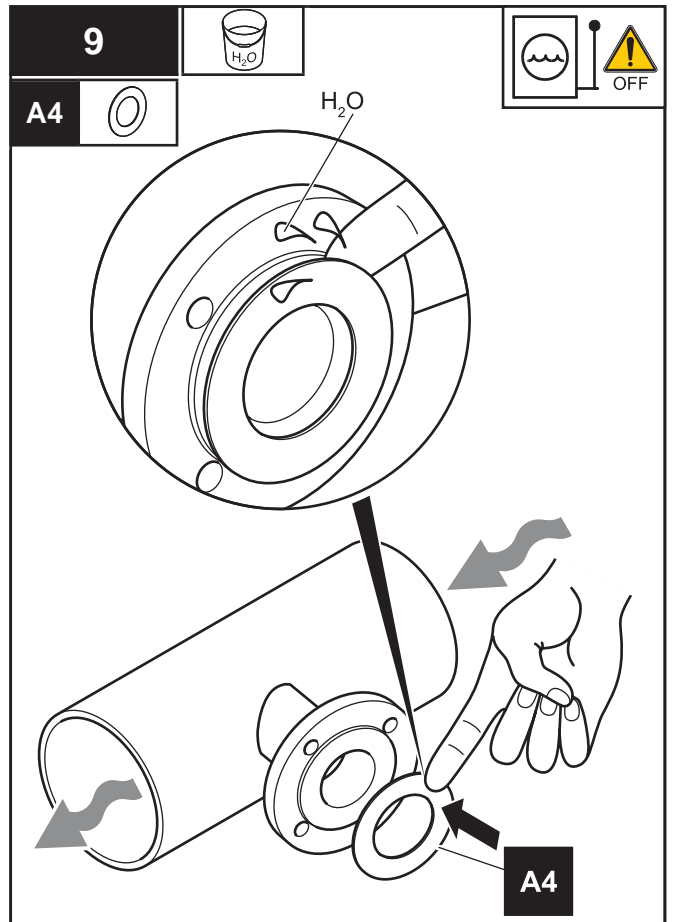
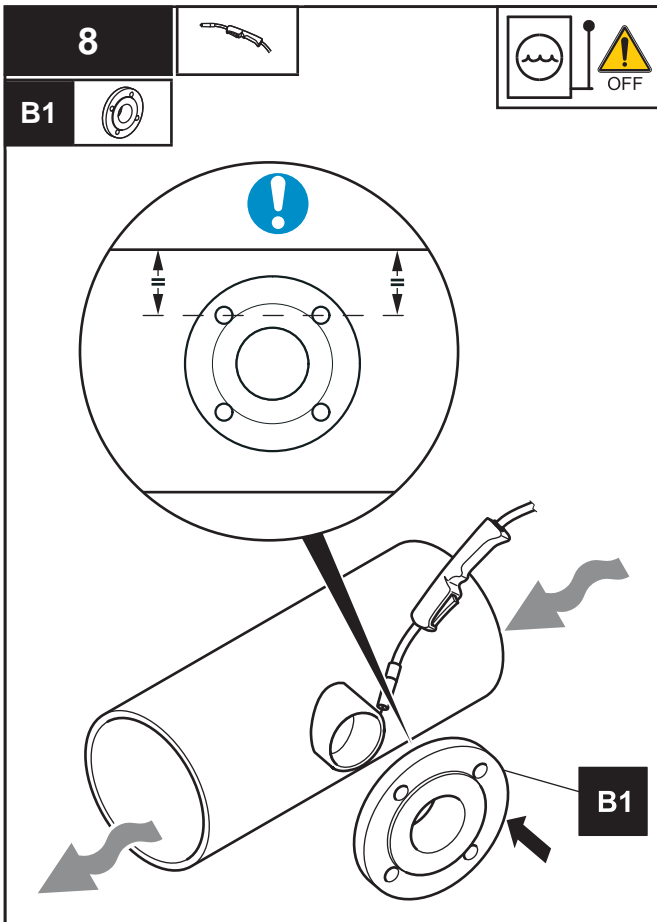
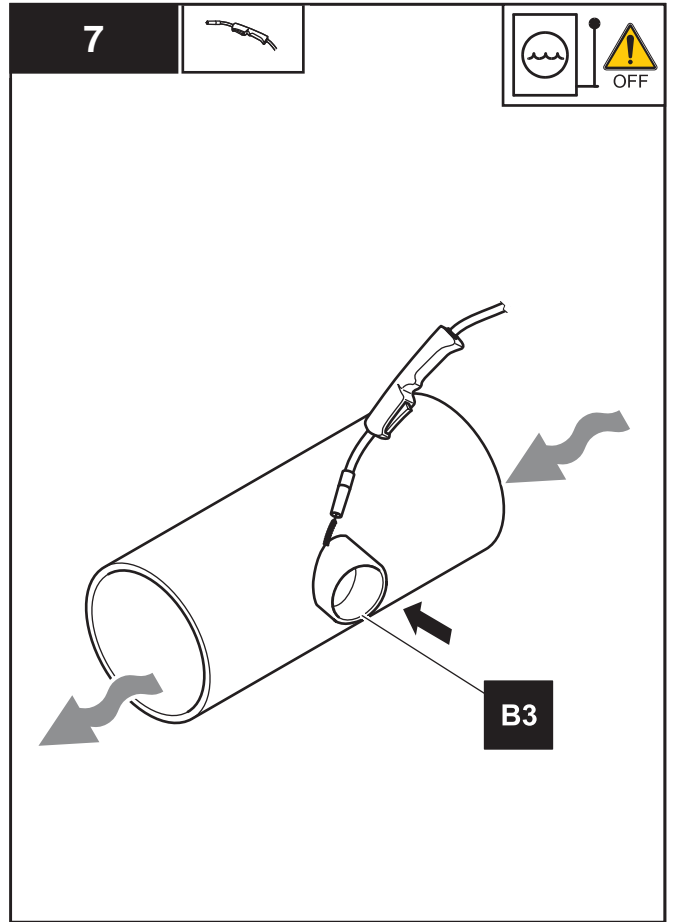
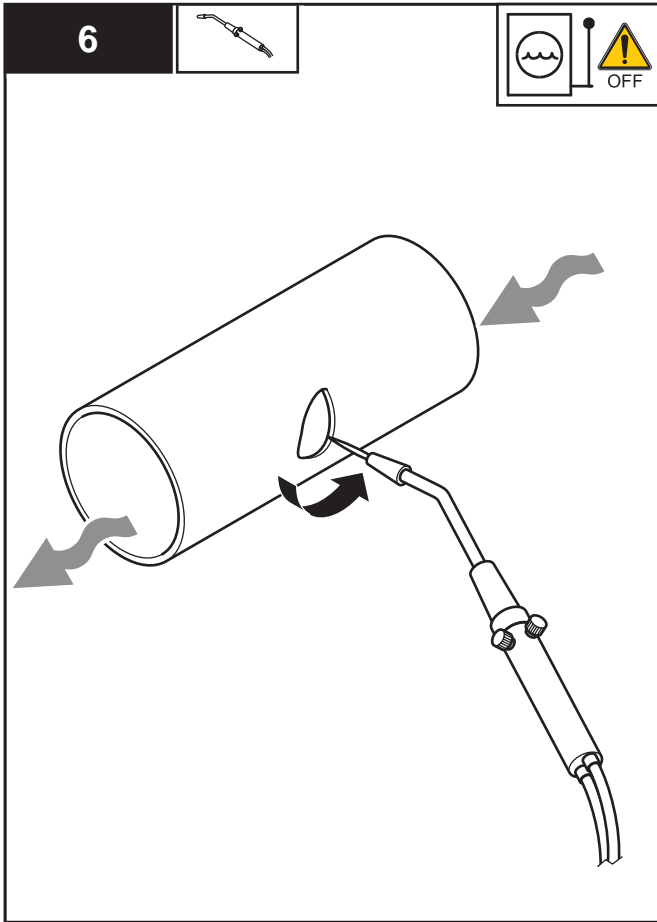

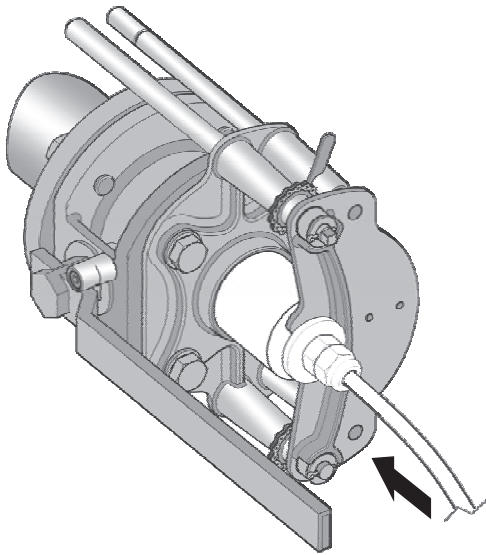

10

A1



A1

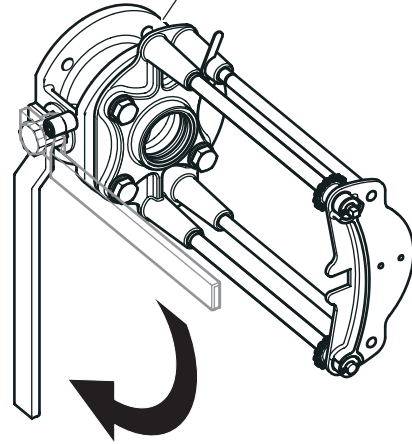

11

24 mm



A3



A3

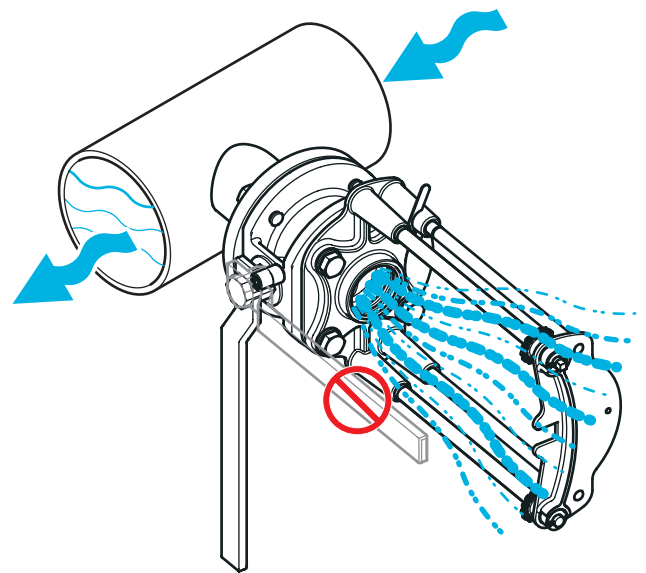
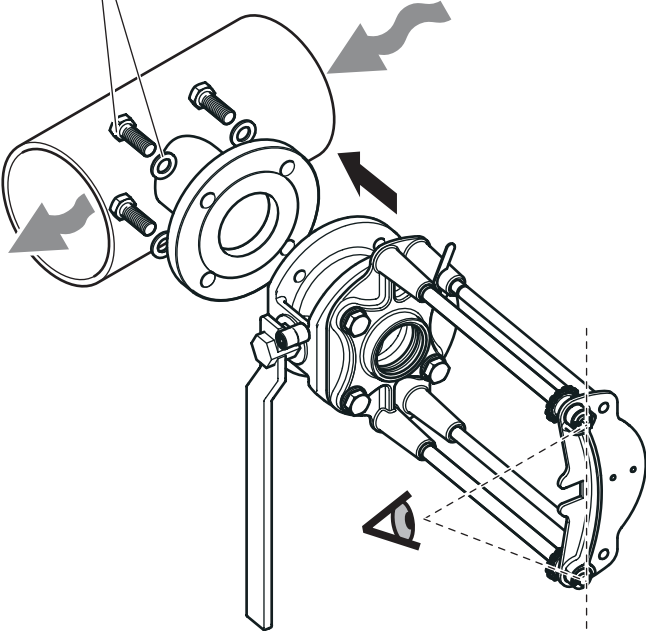

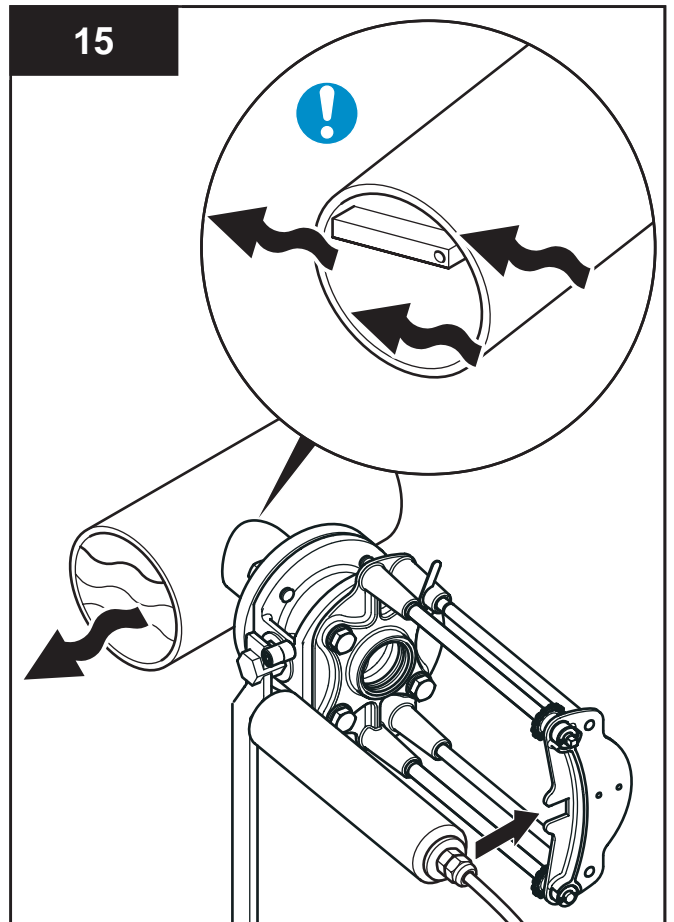
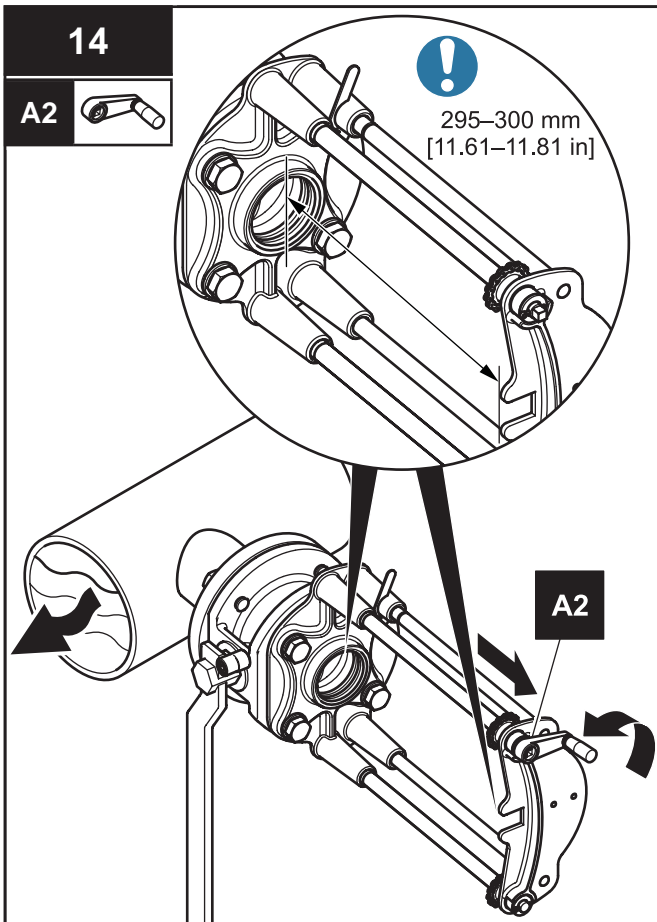
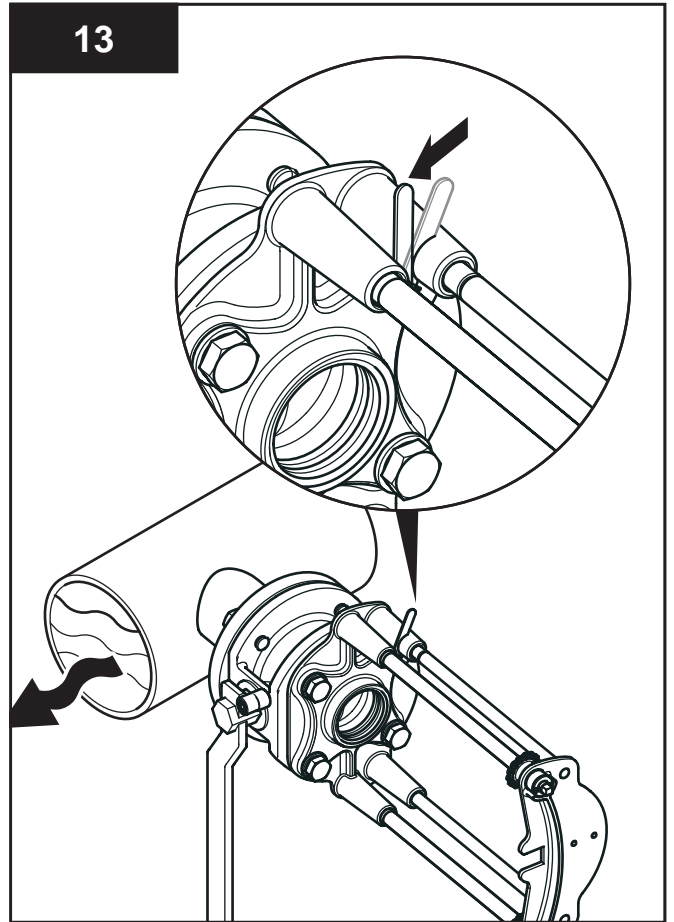
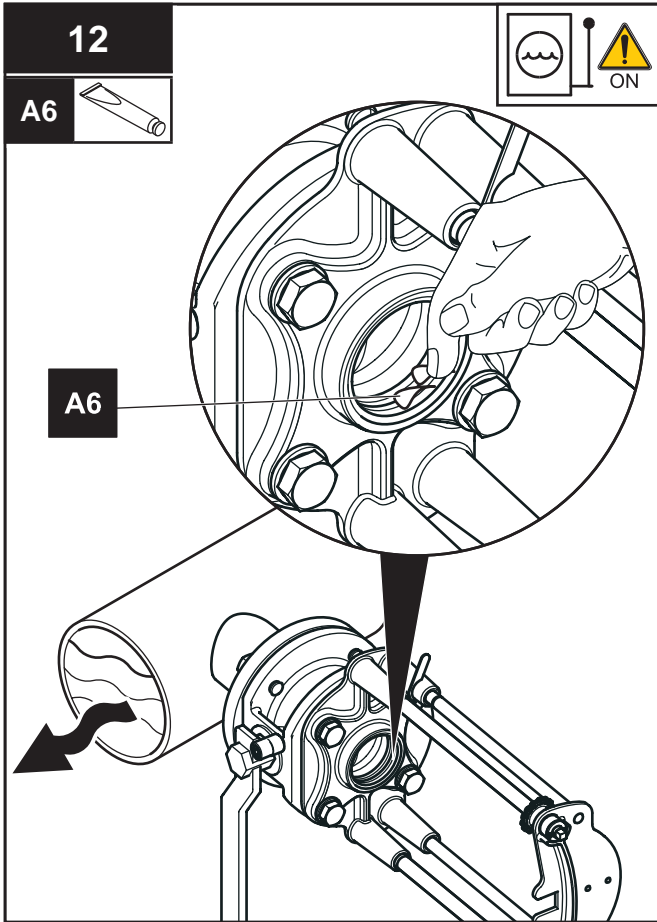

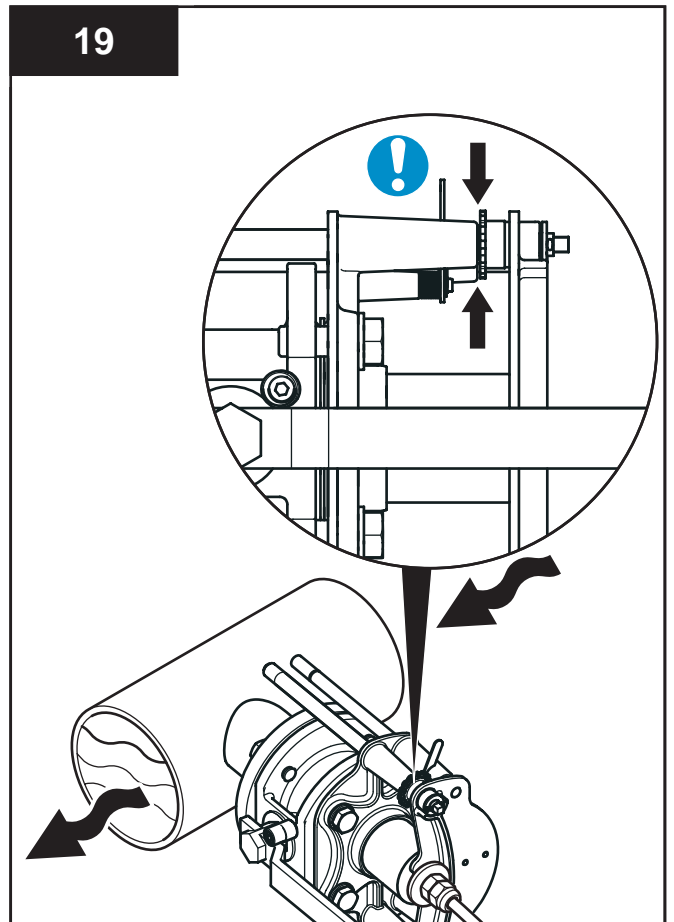
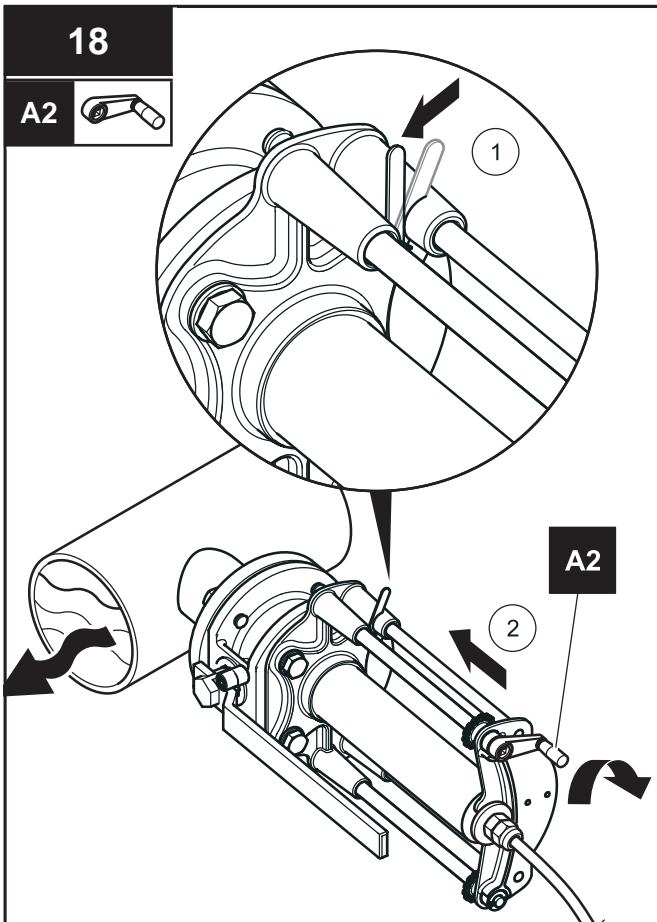
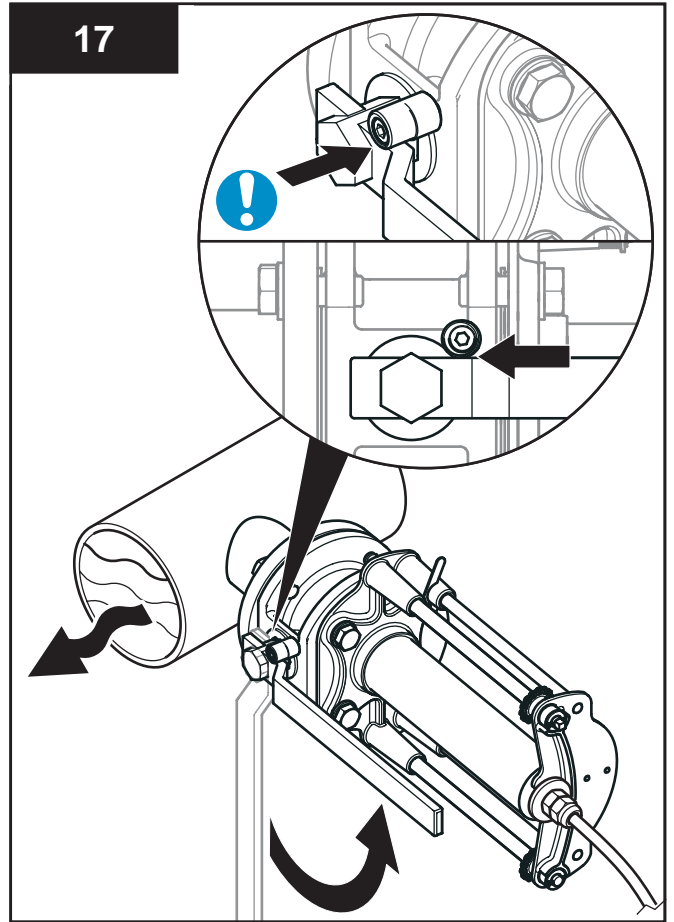
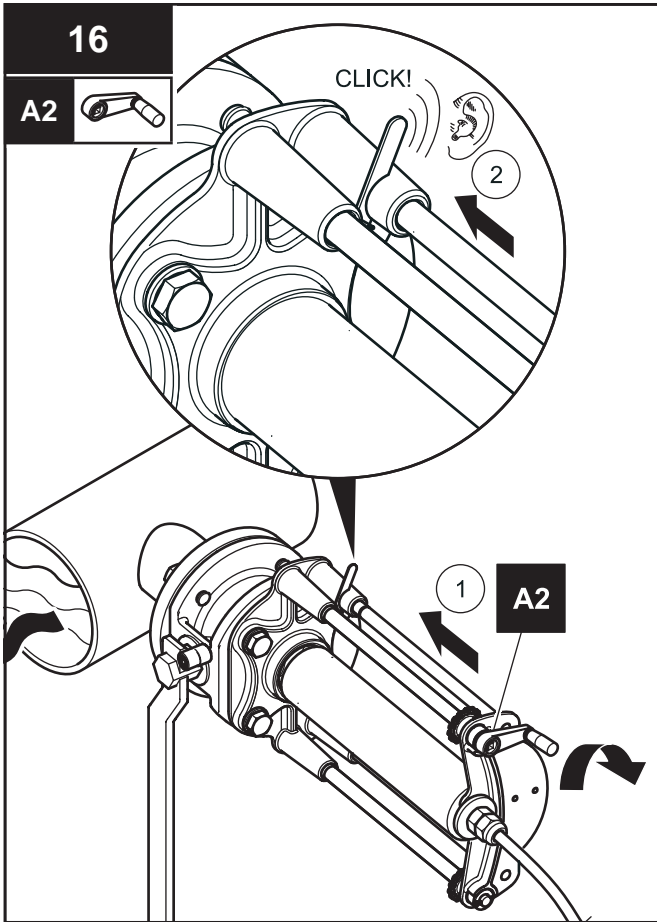

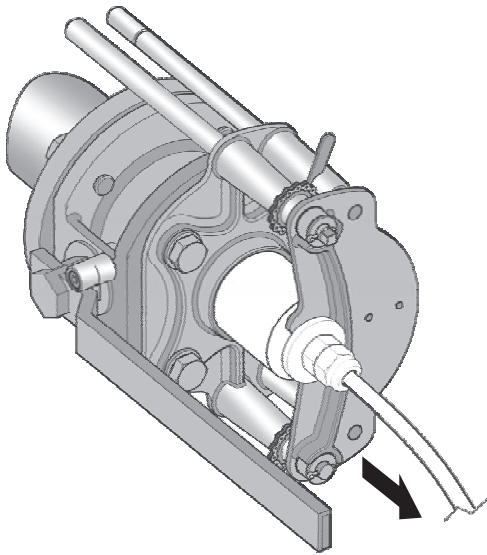

1

A2

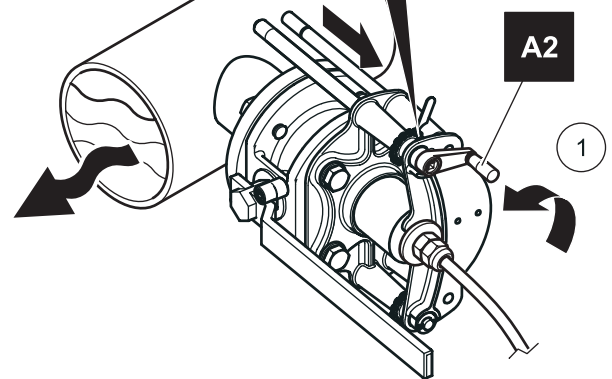
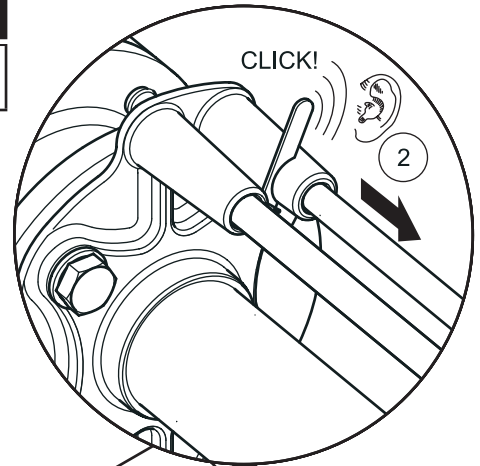

2

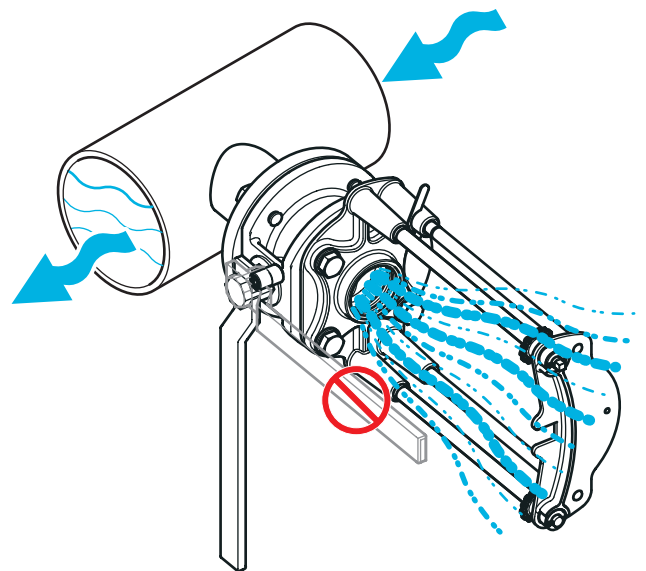
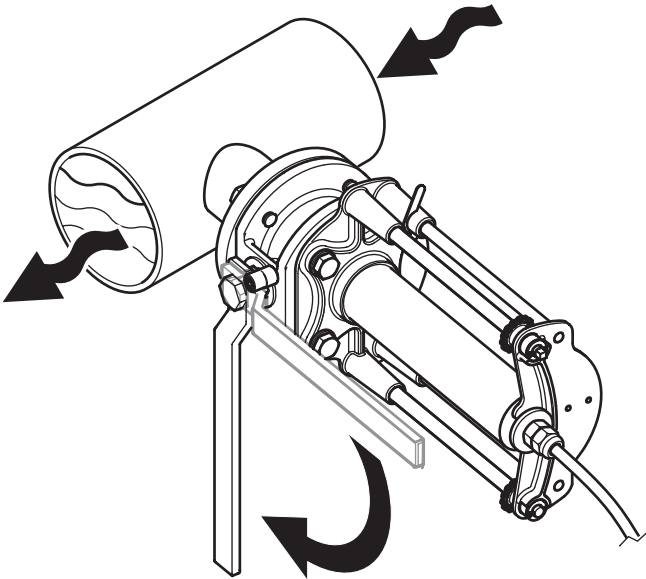

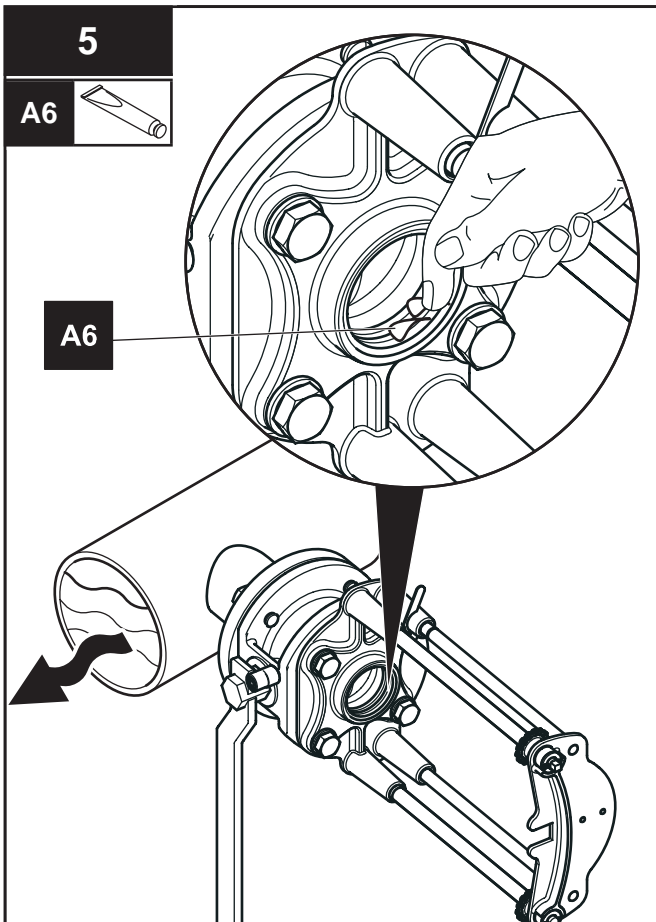
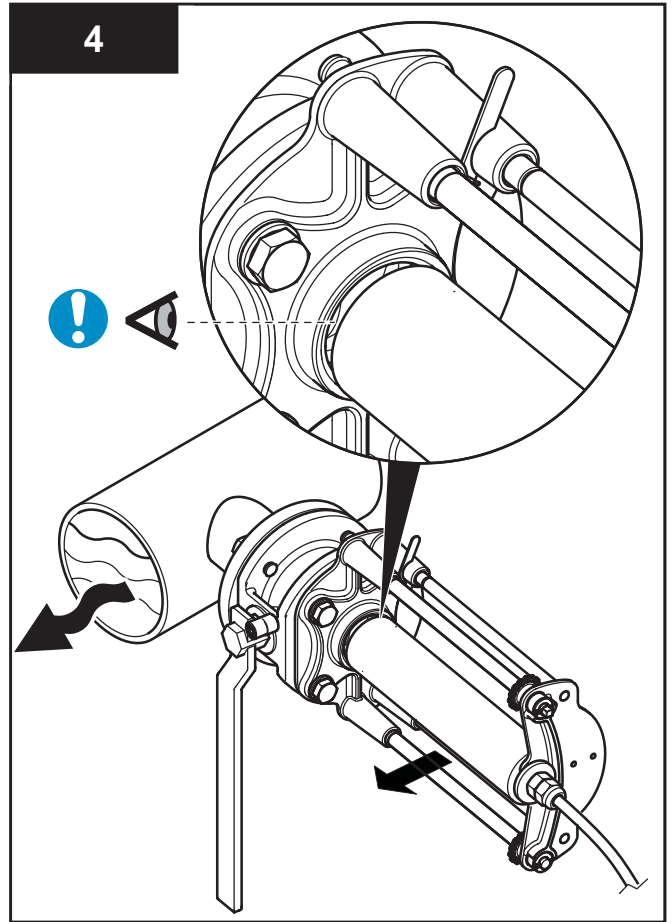
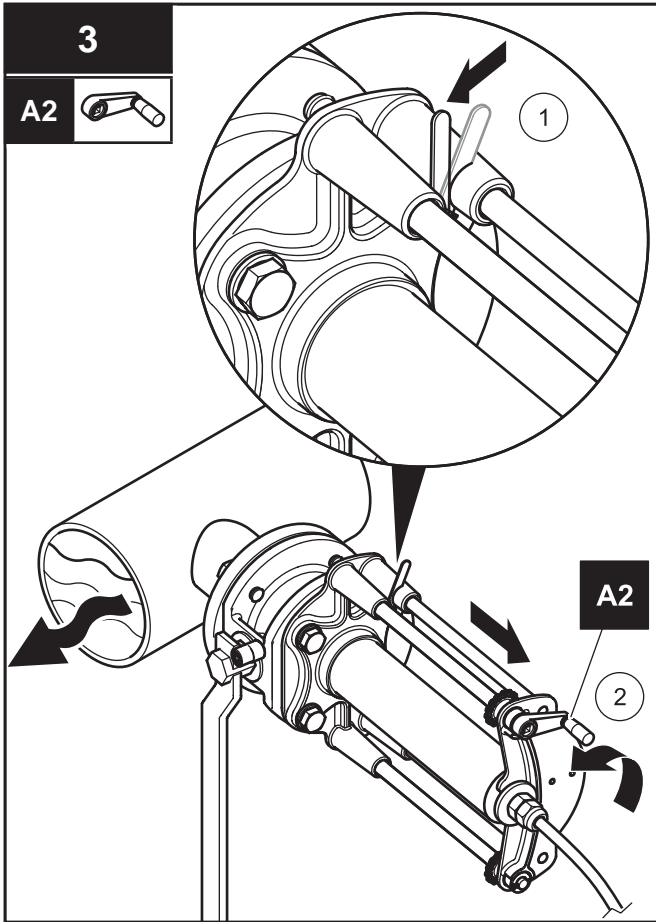

Lined writing area with horizontal lines.

Lined writing area consisting of 25 horizontal lines.

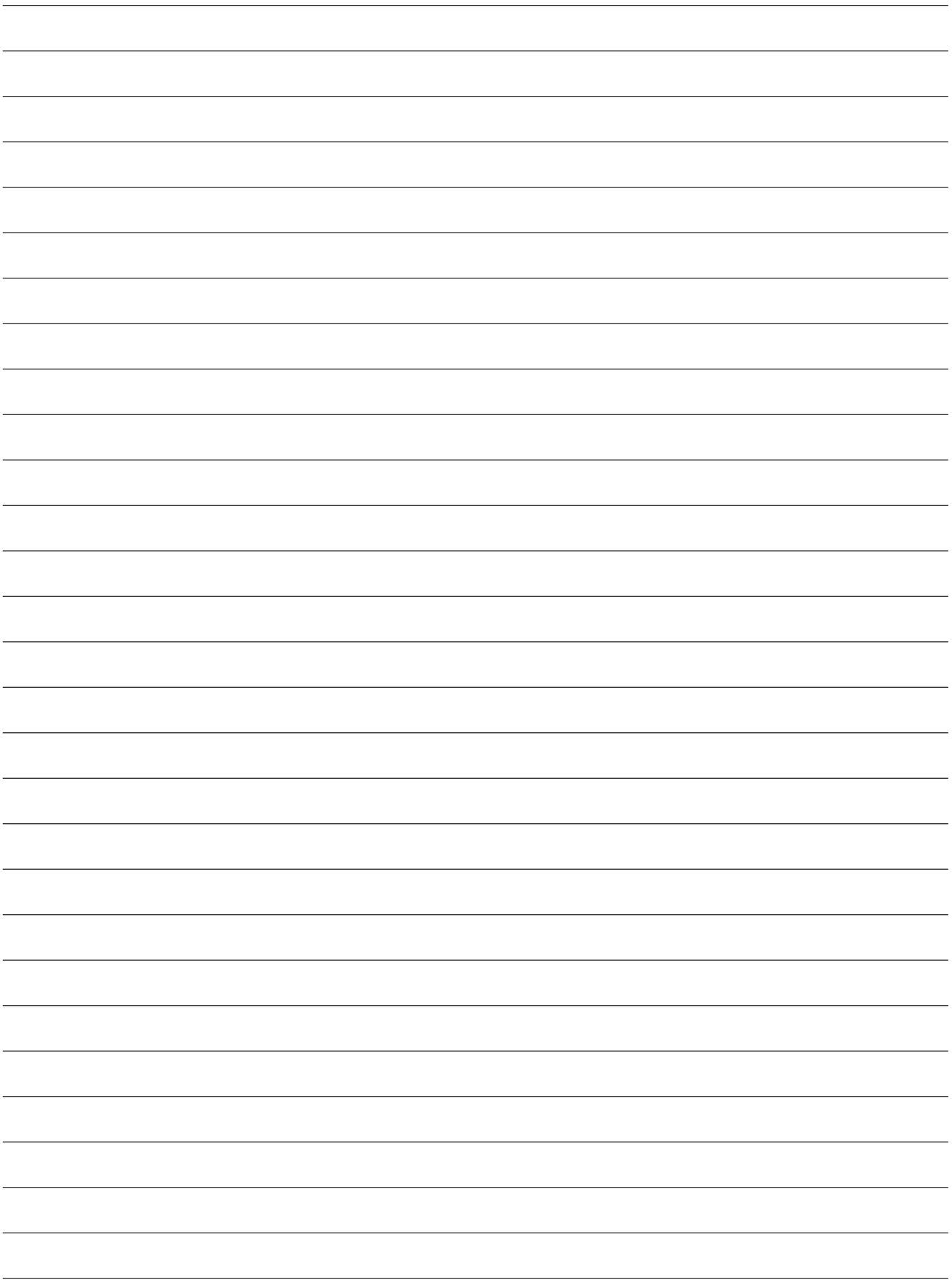

**HACH Company
World Headquarters**
P.O. Box 389
Loveland, Colorado
80539-0389 U.S.A.
Tel (800) 227-HACH
(800) -227-4224
(U.S.A. only)
Fax (970) 669-2932
orders@hach.com
www.hach.com

**Repair Service in the
United States:**
HACH Company
Ames Service
100 Dayton Avenue
Ames, Iowa 50010
Tel (800) 227-4224
(U.S.A. only)
Fax (515) 232-3835

Repair Service in Canada:
Hach Sales & Service
Canada Ltd.
1313 Border Street, Unit 34
Winnipeg, Manitoba
R3H 0X4
Tel (800) 665-7635
(Canada only)
Tel (204) 632-5598
Fax (204) 694-5134
canada@hach.com

**Repair Service in
Latin America, the
Caribbean, the Far East,
Indian Subcontinent, Africa,
Europe, or the Middle East:**
Hach Company World
Headquarters,
P.O. Box 389
Loveland, Colorado,
80539-0389 U.S.A.
Tel +001 (970) 669-3050
Fax +001 (970) 669-2932
intl@hach.com

HACH LANGE GMBH
Willstätterstraße 11
D-40549 Düsseldorf
Tel. +49 (0)2 11 52 88-320
Fax +49 (0)2 11 52 88-210
info@hach-lange.de
www.hach-lange.de

HACH LANGE LTD
Pacific Way
Salford
GB-Manchester, M50 1DL
Tel. +44 (0)161 872 14 87
Fax +44 (0)161 848 73 24
info@hach-lange.co.uk
www.hach-lange.co.uk

HACH LANGE LTD
Unit 1, Chestnut Road
Western Industrial Estate
IRL-Dublin 12
Tel. +353(0)1 46 02 5 22
Fax +353(0)1 4 50 93 37
info@hach-lange.ie
www.hach-lange.ie

HACH LANGE GMBH
Hütteldorferstr. 299/Top 6
A-1140 Wien
Tel. +43 (0)1 9 12 16 92
Fax +43 (0)1 9 12 16 92-99
info@hach-lange.at
www.hach-lange.at

HACH LANGE GMBH
Rorschacherstrasse 30 a
CH-9424 Rheineck
Tel. +41 (0)848 55 66 99
Fax +41 (0)71 886 91 66
info@hach-lange.ch
www.hach-lange.ch

HACH LANGE FRANCE S.A.S.
8, mail Barthélémy Thimonnier
Lognes
F-77437 Marne-La-Vallée
cedex 2
Tél. +33 (0)8 20 20 14 14
Fax +33 (0)1 69 67 34 99
info@hach-lange.fr
www.hach-lange.fr

HACH LANGE NV/SA
Motstraat 54
B-2800 Mechelen
Tél. +32 (0)15 42 35 00
Fax +32 (0)15 41 61 20
info@hach-lange.be
www.hach-lange.be

DR. LANGE NEDERLAND B.V.
Laan van Westroijen 2a
NL-4003 AZ Tiel
Tel. +31(0)344 63 11 30
Fax +31(0)344 63 11 50
info@hach-lange.nl
www.hach-lange.nl

HACH LANGE APS
Åkandevej 21
DK-2700 Brønshøj
Tel. +45 36 77 29 11
Fax +45 36 77 49 11
info@hach-lange.dk
www.hach-lange.dk

HACH LANGE AB
Vinhundsvägen 159A
SE-128 62 Sköndal
Tel. +46 (0)8 7 98 05 00
Fax +46 (0)8 7 98 05 30
info@hach-lange.se
www.hach-lange.se

HACH LANGE S.R.L.
Via Rossini, 1/A
I-20020 Lainate (MI)
Tel. +39 02 93 575 400
Fax +39 02 93 575 401
info@hach-lange.it
www.hach-lange.it

HACH LANGE S.L.U.
Edificio Seminario
C/Larrauri, 1C- 2ª Pl.
E-48160 Derio/Vizcaya
Tel. +34 94 657 33 88
Fax +34 94 657 33 97
info@hach-lange.es
www.hach-lange.es

HACH LANGE LDA
Av. do Forte nº8
Fracção M
P-2790-072 Carnaxide
Tel. +351 214 253 420
Fax +351 214 253 429
info@hach-lange.pt
www.hach-lange.pt

HACH LANGE SP.ZO.O.
ul. Krakowska 119
PL-50-428 Wrocław
Tel. +48 801 022 442
Zamówienia: +48 717 177 707
Doradztwo: +48 717 177 777
Fax +48 717 177 778
info@hach-lange.pl
www.hach-lange.pl

HACH LANGE S.R.O.
Zastrčená 1278/8
CZ-141 00 Praha 4 - Chodov
Tel. +420 272 12 45 45
Fax +420 272 12 45 46
info@hach-lange.cz
www.hach-lange.cz

HACH LANGE S.R.O.
Roľnícka 21
SK-831 07 Bratislava –
Vajnory
Tel. +421 (0)2 4820 9091
Fax +421 (0)2 4820 9093
info@hach-lange.sk
www.hach-lange.sk

HACH LANGE KFT.
Vöröskereszt utca. 8-10.
H-1222 Budapest XXII. ker.
Tel. +36 (06)1 225 7783
Fax +36 (06)1 225 7784
info@hach-lange.hu
www.hach-lange.hu

HACH LANGE S.R.L.
Str. Căminului nr. 3
et. 1, ap. 1, Sector 2
RO-021741 București
Tel. +40 (0) 21 205 30 03
Fax +40 (0) 21 205 30 17
info@hach-lange.ro
www.hach-lange.ro

HACH LANGE
8, Kr. Sarafov str.
BG-1164 Sofia
Tel. +359 (0)2 963 44 54
Fax +359 (0)2 866 15 26
info@hach-lange.bg
www.hach-lange.bg

**HACH LANGE SU
ANALİZ SİSTEMLERİ
LTD.ŞTİ.**
İlkbahar mah. Galip Erdem
Cad. 616 Sok. No:9
TR-Oran-Çankaya/ANKARA
Tel. +90312 490 83 00
Fax +90312 491 99 03
bilgi@hach-lange.com.tr
www.hach-lange.com.tr

HACH LANGE D.O.O.
Fajfarjeva 15
SI-1230 Domžale
Tel. +386 (0)59 051 000
Fax +386 (0)59 051 010
info@hach-lange.si
www.hach-lange.si

HACH LANGE E.Π.E.
Αυλίδος 27
GR-115 27 Αθήνα
Τηλ. +30 210 7777038
Fax +30 210 7777976
info@hach-lange.gr
www.hach-lange.gr

HACH LANGE D.O.O.
Ivana Severa bb
HR-42 000 Varaždin
Tel. +385 (0) 42 305 086
Fax +385 (0) 42 305 087
info@hach-lange.hr
www.hach-lange.hr

HACH LANGE MAROC SARLAU
Villa 14 – Rue 2 Casa Plaisance
Quartier Racine Extension
MA-Casablanca 20000
Tél. +212 (0)522 97 95 75
Fax +212 (0)522 36 89 34
info-maroc@hach-lange.com
www.hach-lange.ma

HACH LANGE OOO
Finlyandsky prospekt, 4A
B. Zentrum "Petrovsky fort", R.803
RU-194044, Sankt-Petersburg
Tel. +7 (812) 458 56 00
Fax. +7 (812) 458 56 00
info.russia@hach-lange.com
www.hach-lange.com