

Data sheet

>>>>SIGMATAX

Sampling and homogenisation

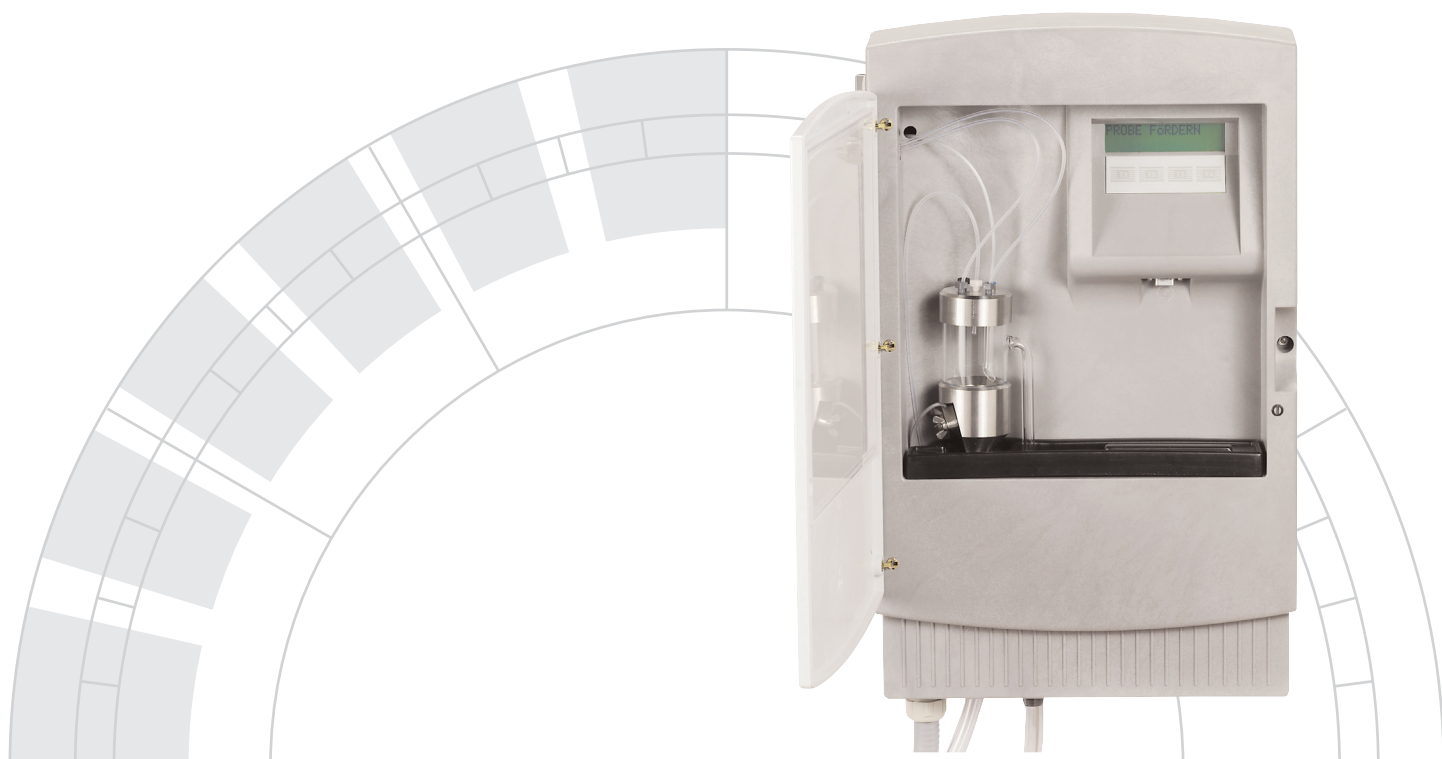

Automatic sampling and homogenisation

Automatic sampling and homogenisation for supplying the PHOSPHAX *sigma* (total phosphorous) and TOCTAX (total organic carbon) process photometers with samples from waters with a particle size < 0.5 mm (waste water treatment outlet).

Comprising: control unit in plastic housing, microprocessor controller with menu operation and alphanumeric liquid crystal display (LCD), sampling probe made of stainless steel with heated connecting hose in various lengths.

Using the immersed sampling probe the volume of sample necessary for the analysis is provided without coming into contact with pumps.

The sample is delivered to a small glass vessel in the control unit and is homogenised using an ultrasonic generator.

>>>>SIGMATAX

Sampling and sample homogenisation

Order numbers

Item no.	Designation
LXV231	SIGMATAX 2 with 10 m connecting hose
LXV232	SIGMATAX 2 with 20 m connecting hose
LXV282	SIGMATAX 2 with 30 m connecting hose
LXV215	Control unit

Further accessories

Item no.	Designation
LZX414.00.00000	Tank edge fastening for the probe
BDA361	Operating instructions
LZX456	Second fastening point (in case of vibration)

Spare parts and consumables

Item no.	Designation
LZX376	Membrane compressor 230 V (for approx. 1.5 years)
LZX394	Sample glass
LZX267	Valve piston
LZX306	Set of consumables, probe valve (for approx. 6 months)
LZX266	Drain valve, complete
LZX300	Air filter, complete
LZX299	Air filter without fittings (for approx. 12 months)
LZX381	Sample glass lid
LZX385	Set of accessories for sample glass lid
HDF167	Maintenance schedule
LZX271	Sampling pipe (inside the probe)
LZX295	Filter for outlet
LZX386	Level pipe with O-ring
LZX269	Probe valve, complete
LZX305	Small sample pipe, straight
LZX293	Small sample pipe, angled
LZX294	Sampling glass (probe body)
LZX275	Sample hoses 1.5 m and 2.0 m
LZX397	Cleaning glass
LZX393/398/411	Probe tube 10 m / 20 m / 30 m
LZX388	Overflow fitting, bottom
LZX284	Ultrasonic transducer, complete

>>>>SIGMATAX

Sampling and sample homogenisation

Dimensions

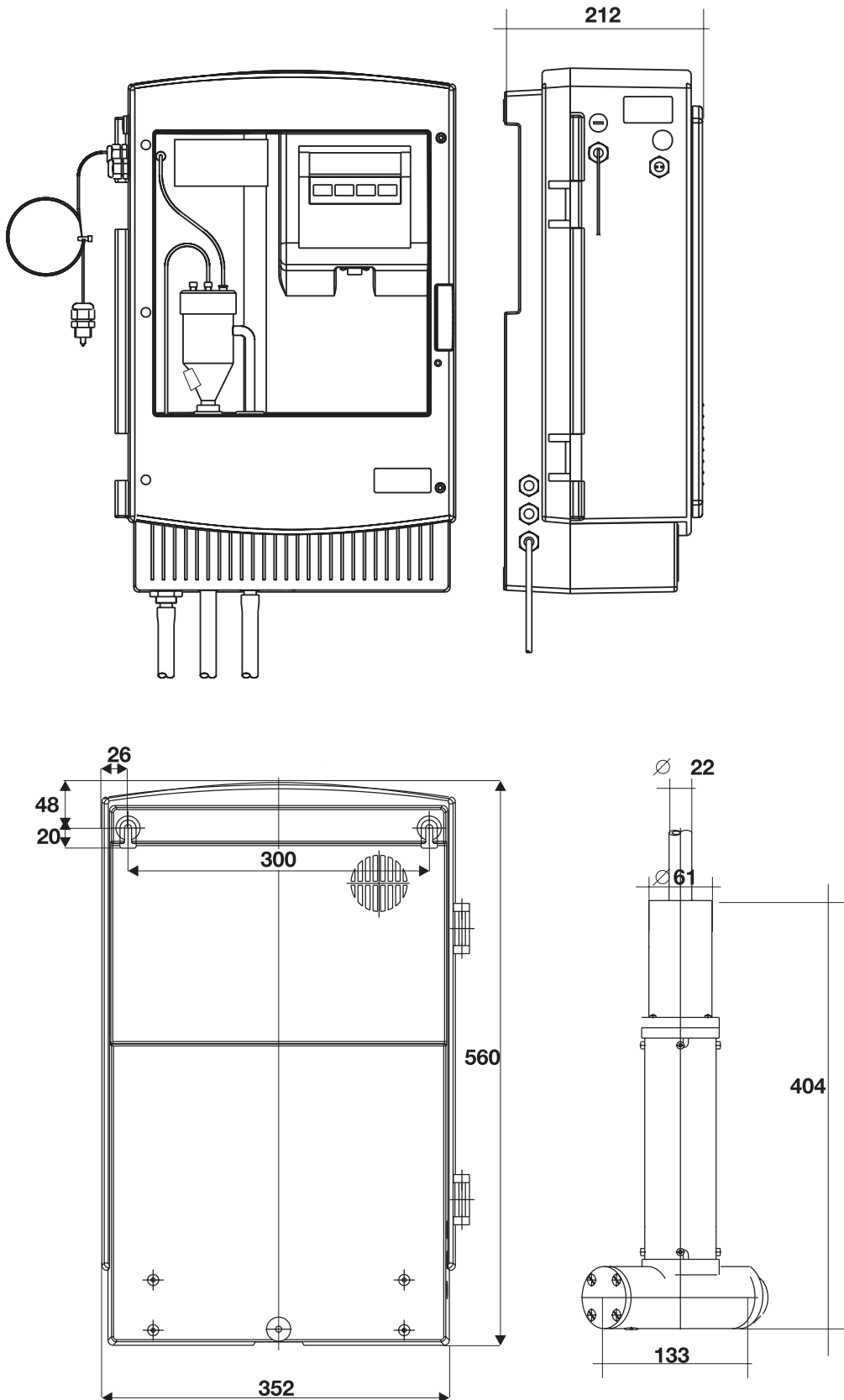

>>>>SIGMATAX

Sampling and sample homogenisation

Technical data

Process principle:	sample pumping controlled by pressure, homogenisation using ultrasound			
Interval:	12-20 min			
Sample volume:	for up to 2 PHOSPHAX <i>sigma</i> or TOCTAX process photometers			
Hose length:	10 m , 20 m, 30 m			
Suction height:	max. 7 m (for hose length 30 m: max. 6 m)			
Ambient temp.:	Control unit: +5 °C to +40 °C Connecting hose: -20 °C to +40 °C (without additional insulation, at lower outdoor temperatures only additional insulation will ensure correct operation. More information available on request.)			
Medium temperature:	+ 5 °C to + 30 °C (probe)			
Enclosure rating:	as per IP 54 (control unit)			
Outputs:	error signalling contact, floating, 24 V, max. 1 A service interface: RS 232			
Mains connection:	230 V AC / 50 Hz			
Power consumption:	Tube	Heating off	Heating on (-20 °C)	
			Continuous operation	Switch on surge
	10 m	150 VA	250 VA	1300 VA
	20 m	150 VA	350 VA	2300 VA
	30 m	150 VA	470 VA	3000 VA
recommended fuse rating: 10 A slow blow				
Servicing interval:	3 months			
User maintenance:	approx. 0.5 h / week, typically			
Dimensions:	Control unit: W x H x D 366 x 560 x 212 mm Probe: D x L 133 x 404 mm			
Mass (approx.):	Control unit:		12 kg	
	Sampling probe 10 m:		7.5 kg	
	Sampling probe 20 m:		15 kg	
	Sampling probe 30 m:		22 kg	
	Mounting pipes:		10 kg	