

PRODUCT SPECIFICATION SHEET

EDI FlexAir[®] Threaded Disc with Universal Saddle Mount

FlexAir Disc diffuser incorporates EDI's advanced technologies for superior aeration performance, flexibility, and reliability.

- Precision die cut openings for high oxygen transfer, uniform air release, and low operating pressure
- High capacity membrane option available for maximum airflow and low operating pressure
- Advanced technology premium quality membrane materials available in EPDM and special polymer blends
- Up to 12 inch (300 mm) of active area
- Triple check valve design prevents entry of liquid/solids into piping. Ideal for on / off applications
- Resistant to fouling and plugging for low maintenance
- Sturdy construction
- Glass fiber reinforced polypropylene construction for maximum chemical, temperature, and UV resistance
- Universal Saddle Mount provides ease of installation and maintenance
- KlicLoc™ retainer for positive mechanical lock
- Available in 3 inch, 4 inch, 90 mm and 110 mm pipe sizes for design flexibility
- Mounts on any pipe material (PVC, ABS, CPVC, SS, etc.).
- Standard units IN STOCK for immediate shipment.

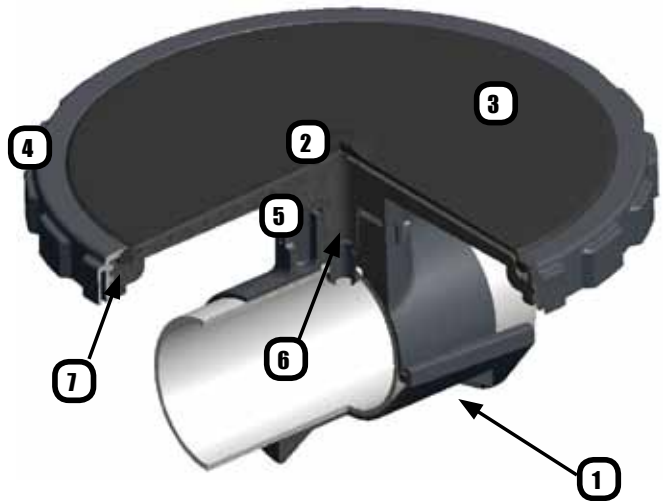

- | | |
|--------------------------------|----------------------|
| 1. KlicLoc™ Retainer | 5. Diffuser Body |
| 2. Primary Check Valve Feature | 6. Air Inlet Orifice |
| 3. Flexible Membrane Media | 7. EZSeal™ |
| 4. Membrane Retainer Ring | |



PRODUCT SPECIFICATION SHEET

The FlexAir disc diffuser provides high mechanical strength, operating flexibility and oxygen transfer efficiency.

The FlexAir disc diffuser is provided with premium quality membrane materials that are engineered by the EDI Membrane Technologies division. EDI's proprietary membrane materials are engineered for superior product life. Multiple membrane perforations are available to optimize the performance of the diffuser for maximum operating efficiency, air handling capacity, or operating pressure. An integral triple check valve feature prevents the backflow of liquid into the diffuser and piping.

The FlexAir disc diffuser is ideally suited for on/off applications and requires minimal maintenance for long-term performance.

The diffuser assembly and Universal Saddle Mount is available in glass-fiber reinforced polypropylene for maximum performance. This material option offers greater mechanical and temperature capabilities as conventional PVC or CPVC products. The Integral Saddle Mount is compatible with any pipe material and is available in 3 inch, 4 inch, 90 mm and 100 mm diameter sizes. This flexibility allows the air conveyance system to be sized to match project objectives with minimum pressure loss.

The Universal Saddle Mount features an air inlet port that inserts into the pipe and the KlicLoc™ retainer positively locks the assembly to the lateral piping. A 3/4 inch diameter threaded connection is used to join the diffuser and saddle assembly. This allow either component to be replaced as required.

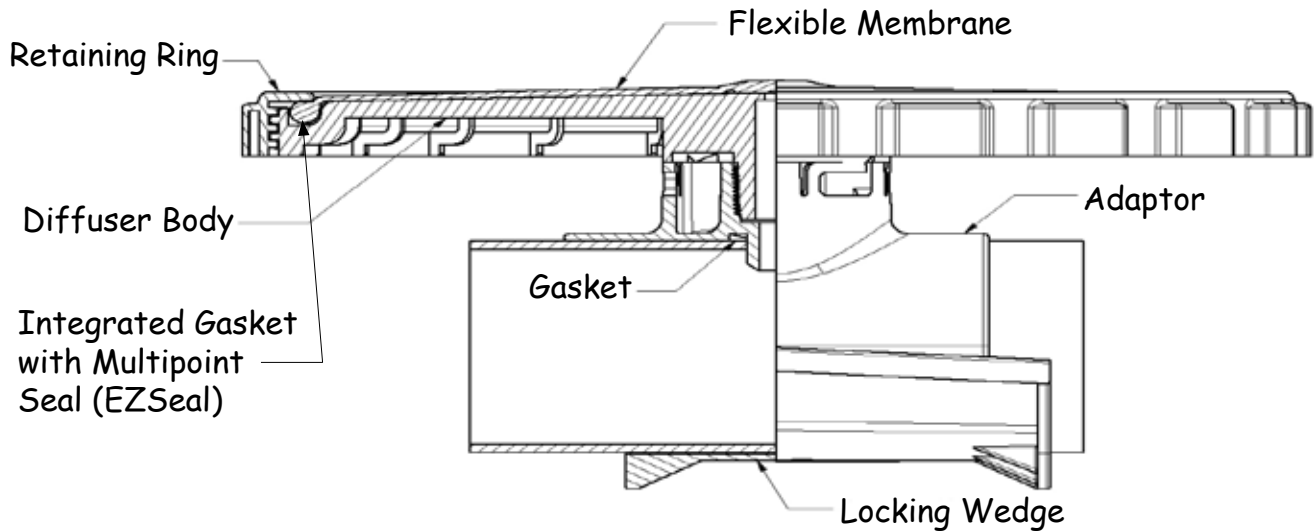

Diffuser Type	Design Airflow		Overall Diameter		Active Surface Area		Dry Weight		Net Operating Buoyancy	
	scfm	m ³ _N /h	in	mm	ft ²	m ²	lb	kg	lb	kg
12" Micro	0-10	0-16	13.8	351	0.73	0.068	2.8	1.3	2.2	1.0
12" High Cap	0-18	0-29	13.8	351	0.73	0.068	2.8	1.3	2.2	1.0

- Optimum oxygen transfer efficiency is achieved when operating in the middle to low end of the airflow range. The approximate operating pressure of the diffuser at the mid-range is 13-16 inches H₂O (3.2-4.0kPa).
- Operating the unit at the high end of the range will result in reduced performance and increased operating pressure. Use the maximum airflow value for short term operations such as peak loads or system maintenance.



Environmental Dynamics International

5601 Paris Road • Columbia, MO 65202 USA
+1 877.EDI.AIR8 (334.2478) +1 573.474.9456

For Parts Information:
parts@wastewater.com
www.diffuserexpress.com

For System Information:
systems@wastewater.com
www.wastewater.com