

## EBS Filters

The largest automatic self-cleaning filter for fine filtration



flow rates

**up to 7200 m<sup>3</sup>/h  
(32000 US gpm)**

filtration degrees

**800-10 micron**

water for cleaning

**less than 1%  
of the total flow**

minimum operating pressure

**2 bar (30 psi)**

### features:

- Large filtration area, reliable operating mechanism and simple construction make the EBS filter the ideal solution for filtration of high-flow and poor quality water to very finefiltration degrees
- Automatic flushing according to pressure differential and/or time
- No interruption of downstream flow during flushing
- Robust and reliable self-cleaning mechanism even on marginal operation conditions
- Minimal volume of reject water allows excellent operation during flush mode
- Applications: Water supply systems, Irrigation systems, Cooling Water, Wastewater Treatment, Industrial Pre-Filtration, etc.
- Industries: manufacturing, mining, water and wastewater treatment plants, turf and agriculture, etc.

## How the EBS Filters Work

### General

The Amiad EBS Series are automatic filters, with an electric self-cleaning mechanism.

The “EBS” filters range in flow-rates of up to 7200 m<sup>3</sup>/h (32000 US gpm), with screens designed ranging from 800-10 micron filtration degree. Inlet/Outlet flanges are available from 8”-36” diameter.

### The Filtering Process

Raw water enters from the filter inlet (1) and passes through the screen (2). Clean water flows through the filter outlet (3).

The gradual dirt buildup on the inner screen surface causes a filter cake to develop, with a corresponding increase in the pressure differential across the screen. A pressure differential switch (4) senses the pressure differential and when it reaches a pre-set value, the cleaning process begins.

### The Self-Cleaning Process

Cleaning of the filter is carried out by the suction scanner (5) which spirals across the screen, the open exhaust valves creates a high velocity suction stream at the nozzle tip which “vacuums” the filter cake from the screen. During the self-cleaning process, which takes approximately 30 seconds, filtered water continues to flow downstream.

### The Control System

The “EBS” operation and cleaning cycle is controlled and monitored by a Programmable Logic Control (PLC).

The PLC allows maximum flexibility in control options and has many features that can be incorporated per customer’s needs.

During the self-cleaning cycle the PLC controls a solenoid that operates the exhaust valve by means of a hydraulic command or compressed air.

The self-cleaning cycle begins under any one of the following conditions:

1. Receiving a signal from the Pressure Differential Switch
2. Time interval parameter set at the control board
3. Manual Start

The control board also provides:

- Optional continuous flush mode
- Flush cycles counter
- Alarm output – may be used to open a bypass, shut-off a pump, etc.

### “EBS” Models

Amiad’s “EBS” product-line consists of the following models:

- EBS-10000 for up to 1200 m<sup>3</sup>/h (5300 US gpm)
- EBS-15000 for up to 1800 m<sup>3</sup>/h (8000 US gpm)
- Mega EBS 40000 which consists of four EBS-10000 screen elements for up to 4800 m<sup>3</sup>/h (21100 US gpm)
- Mega EBS 60000 which consists of four EBS-15000 screen elements for up to 7200 m<sup>3</sup>/h (32000 US gpm)

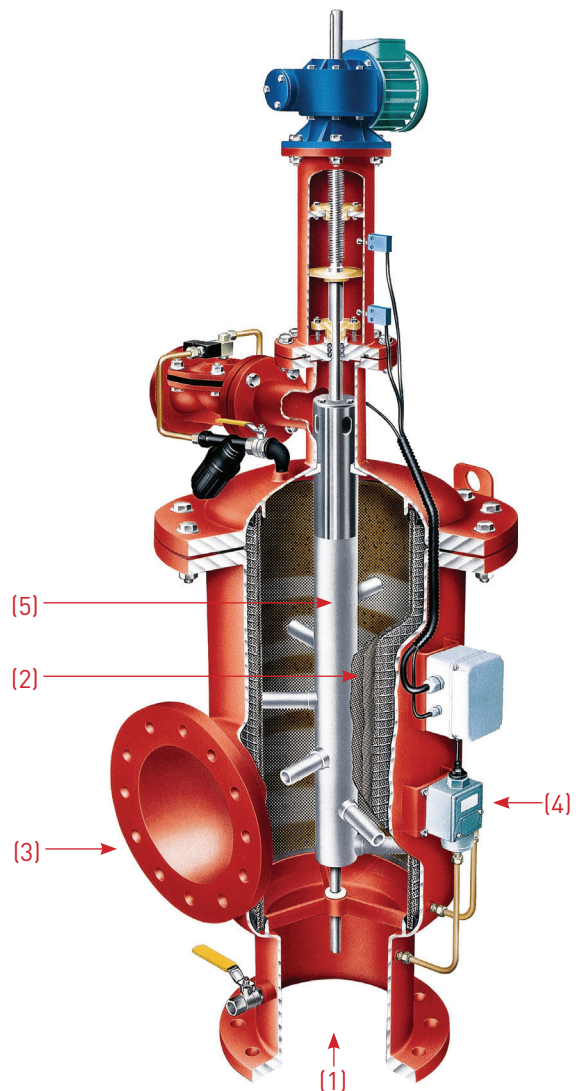

## EBS 10000



## ON-LINE

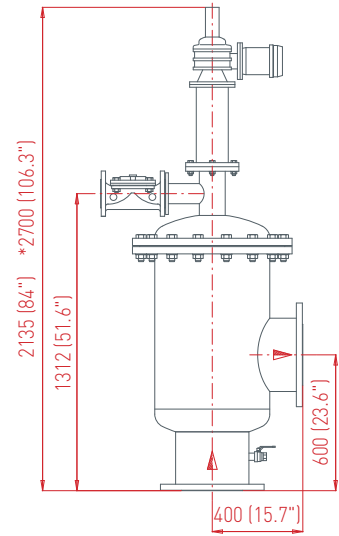

## EBS 15000

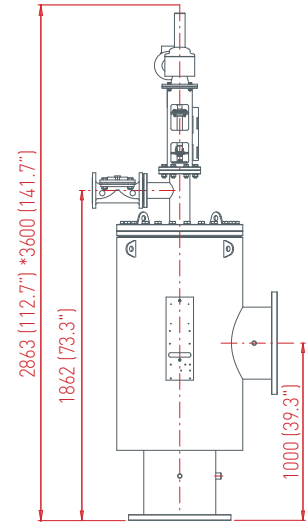
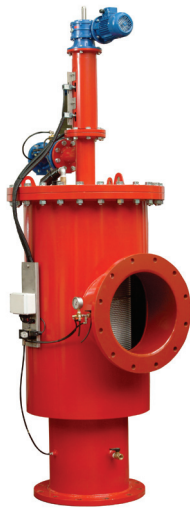

## MEGA EBS 40000

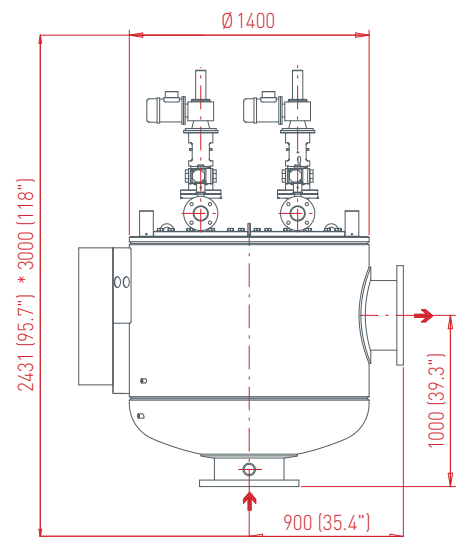

Dim. in mm (inch)

\*Approx. length required for maintenance

# IN-LINE

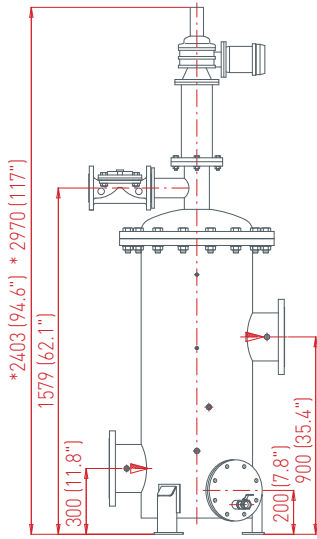

# Head Loss Graphs

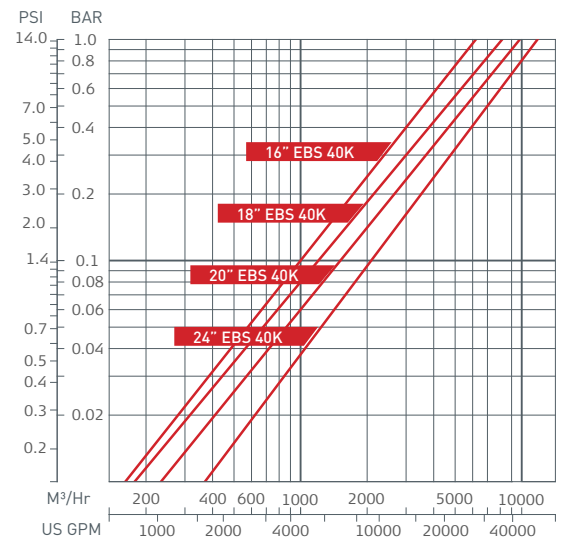
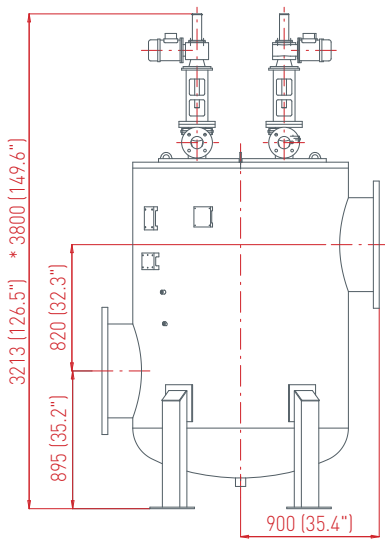
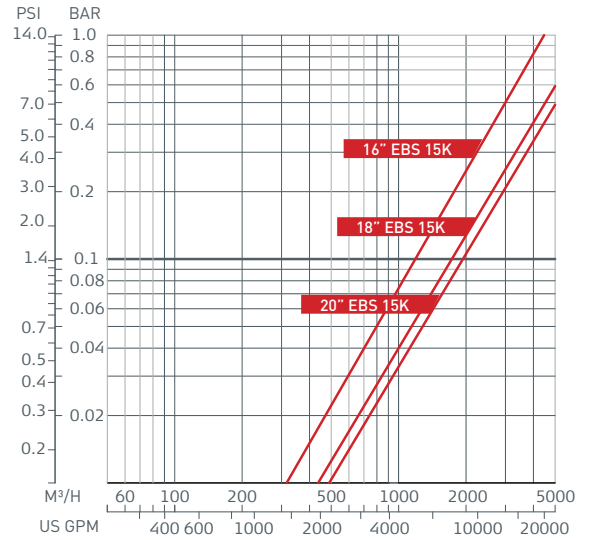
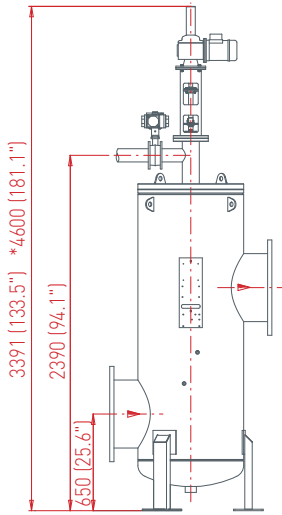
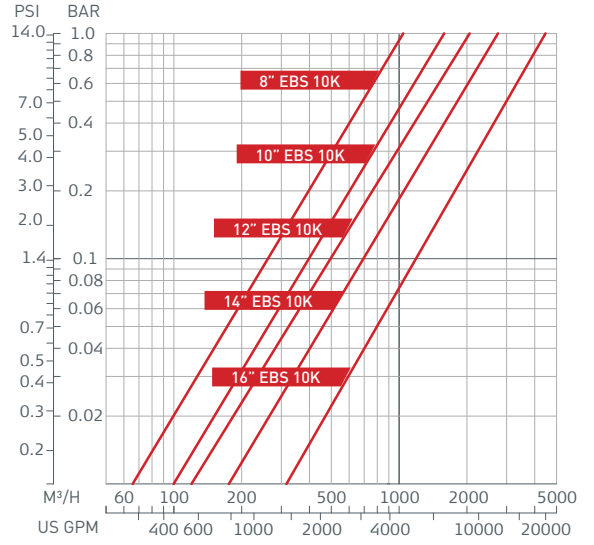

**Dim. in mm (inch)**

\*Approx. length required for maintenance

## Technical Specifications

Filter Type	EBS 10000	EBS 15000	Mega EBS 40000	Mega EBS 60000
-------------	-----------	-----------	----------------	----------------

General Data				
Maximum flow rate*	1200 m <sup>3</sup> /h (5300 US gpm)	1800 m <sup>3</sup> /h (8000 US gpm)	4800 m <sup>3</sup> /h (21100 US gpm)	7200 m <sup>3</sup> /h (32000 US gpm)
Inlet/Outlet diameter	8"-16" (200-400 mm)	10"-20" (250-500 mm)	16"-24" (400-600 mm)	20"-36" (500-900 mm)
Standard filtration degrees	Weave Wire Screen 800, 500, 300, 200, 130, 100, 80,50, 25, 10 micron			
Min. working pressure	2 bar (30 psi)			
Max. working pressure	10 bar (145 psi) 16 bar (232 psi) upon request			
Max. working temperature	60°C (140°F)			
Electrical Supply	3 phase, 220/380/440 VAC 50/60 Hz			
Weight [empty On-line models]	490 kg (1080 lb)	684 kg (1508 lb)	2250 kg (4960 lb)	6200 kg (13670 lb)

\* Consult Amiad for optimum flow depending on filtration degree & water quality

Flushing Data				
Minimum flow for flushing (at 2 bar - 30 psi)	50 m <sup>3</sup> /h (220 US gpm)	50 m <sup>3</sup> /h (220 US gpm)	50 or 200 m <sup>3</sup> /h (220 or 880 US gpm)*	50 or 200 m <sup>3</sup> /h* (220 or 880 US gpm)*
Reject water volume per flush cycle	420 liter (111 US gallon)	500 liter (132 US gallon)	1680 liter (444 US gallon)	2000 liter (528 US gallon)
Flushing cycle time	30 seconds	36 seconds	30 or 120 seconds*	144 or 36 seconds*
Exhaust valve	3" (80 mm)	3" (80 mm)	4 units of 3" (4 units of 80 mm)	4 units of 3" (4 units of 80 mm)
Flushing criteria	Differential pressure of 0.5 bar (7 psi), time intervals and manual operation			

\*One by one or all four screens simultaneously

Screen Data				
Filter area	10000 cm <sup>2</sup> (1500 in <sup>2</sup> )	15000 cm <sup>2</sup> (2325 in <sup>2</sup> )	40000 cm <sup>2</sup> (6200 in <sup>2</sup> )	60000 cm <sup>2</sup> (9300 in <sup>2</sup> )
Screen types	Four-layer Weave Wire stainless steel 316L			

Control and Electricity				
Rated operation voltage	3 phase, 220/380/440 VAC 50/60 Hz			
Electric motor 20 / 24 Gear output RPM	½ HP	½ HP	4 x ½ HP	4 x ½ HP
Current consumption	1.5 Amp	1.5 Amp	5 Amp	5 Amp
Control voltage	24 VAC			

*Construction Materials				
Filter housing and lid	Epoxy or Polyester coated carbon steel 37-2			
Cleaning mechanism	Stainless steel 316L, Acetal			
Exhaust valve	Epoxy-coated cast iron, Natural rubber			
Seals	Synthetic rubber, Teflon			
Control	Aluminum, Brass, Stainless steel, PVC, Nylon			

\* Amiad offers a variety of construction materials and screens. Please consult us for specifications



Municipal



Industry



Irrigation

**Hyxo Oy**

P.O. Box 16 (Palokorvenkatu 2)  
FI-04261 Kerava, Finland  
Tel. +358 10 417 4500  
Fax +358 10 417 4501  
hyxo@hyxo.fi • www.hyxo.com

**Headquarters**

Amiad Water Systems Ltd. D.N. Galil Elyon 1, 12335, Israel,  
Tel: 972 4 690 9500, Fax: 972 4 690 9391,  
E-mail: info@amiad.com

**North America**

Amiad Filtration Systems, 2220 Celsius Avenue, Oxnard,  
California 93030, USA, Tel: 1 805 988 3323, Fax: 1 805 988 3313,  
E-mail: info@amiadusa.com

**South America**

Amiad Oil & Gas, Benito Nardone 2219, Montevideo, Uruguay,  
Tel: 598 2 7117617, Fax: 598 2 7120816,  
E-mail: amisur@adinet.com.uy

**Chile**

Amiad Andina, Carretera General San Martín 16.500 No 30,  
Loteo Industrial Los Libertadores, Colina, Santiago de Chile,  
Tel: 56 2 489 5100, Fax: 56 2 489 5101,  
E-mail: amiadandina@amiad.com

**Brazil**

E-mail: amiad@amiad.com.br

**Europe**

Amiad Water Systems Europe SAS, Ilot No4 ZI La Boitardière,  
37530 Chargé, Tel: 33 (0) 2 47 23 01 10, Fax: 33 (0) 2 47 23 80 67,  
E-mail: info@amiadfrance.com

**Germany**

Amiad Filtration Solutions (2004) Ltd. Zweigniederlassung  
Deutschland Prinz-Regent-Str. 68 a 44795 Bochum,  
Tel: 49 (0) 234 588082-0, Fax: 49 (0) 234 588082-12,  
E-mail: info@amiad.de

**Turkey**

FTS – Filtration & Treatment Systems, Istanbul yolu 26 Km,  
Yurt Orta Sanayii, Saray, Ankara, Tel: 90 312 8155266/7,  
Fax: 90 312 8155248, E-mail: info@fts-filtration.com

**India**

Amiad Filtration India Pvt Limited, 305 Sai Commercial Building  
Govandi St Rd, Govandi Mumbai 400 088, Tel: 91 22-67997813/14,  
Fax: 91 22-67997814, Email: info@amiadindia.com

**China**

Yixing Taixing Environtec Co., Ltd. 70 Baihe Chang, Xingjie Yixing  
Jiangsu, 214204, Tel: 86 510 87134000, Fax: 86 510 87134999,  
E-mail: marketing@taixing.cc

**South-East Asia**

Filtration & Control Systems Pte. Ltd., 19B Teo Hong Road,  
088330 Singapore, Tel: 65 6 337 6698, Fax: 65 6 337 8180,  
E-mail: fcs1071@pacific.net.sg

**Australia**

Amiad Australia Pty Ltd. 138 Northcorp Boulevard,  
Broadmeadows, Victoria 3047,  
Tel: 61 3 93585800, Fax: 61 3 93585888,  
E-mail: sales@amiad.com.au

www.amiad.com

NP.00894/10.2011

