



Applications

- Drinking water: ground water, sea water (desalination), distribution network and surface water
- Process water: boiler and cooling systems, food and beverage
- Waste and reused water

Process: Total and free chlorine

CLT10 sc / CLF10 sc: Total and free reagentless chlorine sensors

Disinfection under control

HACH LANGE's self diagnostics alerts you when the process has changed or the instrument needs servicing. Diagnostic features include the CAL WATCH algorithm for warning of pH and chlorine calibration deviation and a non-contacting sample flow sensor for notification of insufficient sample flow. All warnings are easy to configure. CAL WATCH is unique in the market.

Minimal operation costs

The amperometric sensors monitor chlorine concentration continuously without reagents. There is no need neither to replace reagents nor to manage disposal. This saves time and keeps operation costs at a low level.

Plug and play

The sensors are designed for all HACH LANGE digital SC controllers so you only need to know one controller for all measurements. They are easy to operate, no matter if measuring turbidity or chlorine. HACH LANGE SC controllers have no complicated wiring or setup procedures. Simply plug in any HACH LANGE digital sensor and it's ready to use without software configuration.

Real-time process control

Continuous readings indicate when treatment conditions have changed allowing CLT10 sc and CLF10 sc a real-time control of disinfection processes.

EPA compliant according to Method 334.0

In accordance with the US EPA Method 334.0, the sensors can be used for reporting chlorine residual measurements.

Extended up-time via various service options

The HACH LANGE ISO certified service is available close to you. It offers a range from one-off installation service to warranty extension up to 5 years. Thus, the lifetime of the system is increased and costs become transparent and foreseeable.

Complete solutions for disinfection analysis

HACH LANGE is a recognised expert in disinfection with a unique product spectrum. The CLT10 sc and CLF10 sc amperometric sensors complement online chemical analysis solutions and the amperometric and chemical laboratory solutions.



UNITED FOR WATER QUALITY

CLT10 sc / CLF10 sc: Total and free reagentless chlorine sensors

Technical data

Chlorine sensor

Measurement range

0 to 10 ppm

Lower limit of detection (LOD)

30 ppb (0.03 ppm) or lower

Limit of quantitation (LOQ)

90 ppb (0.09 ppm) or lower

Resolution

0.001 ppm (1 ppb)

Accuracy

Free chlorine: $\pm 3\%$ of the reference test* (DPD) at constant pH less than 7.2 (± 0.2 pH unit)

Free chlorine: $\pm 10\%$ of the reference test* (DPD) at stable pH less than 8.5 (± 0.5 pH unit from the pH at calibration)

Total chlorine: $\pm 10\%$ of the reference test* (DPD) at stable pH less than 8.5 (± 0.5 pH unit from the pH at calibration)

Total chlorine: $\pm 20\%$ of the reference test* (DPD) at stable pH greater than 8.5

Repeatability

30 ppb or 3 %, whichever is greater

Response times

140 seconds or less for 90 % change (T90) at a stable temperature and pH

Total chlorine: 100 seconds or less for 90 % change (T90) at a stable temperature and pH

Sampling time

Continuous

Interferences

Free chlorine: monochloramine, chlorine dioxide, ozone, and chalk deposits.

Total chlorine: chlorine dioxide, ozone and chalk deposits

Pressure limit

0.5 bar, no pressure impulses and/or vibrations

Sample flow rate

30 to 50 L/hour, optimal is 40 L/hour

pH range of sample

pH 4 to 9

Sample temperature (compensated for fluctuations)

5 to 45 °C

Temperature compensation

Internal temperature compensation in the sensor

Storage temperature

0 to 50 °C dry, without electrolyte

15 to 25 °C with electrolyte

Dimensions (D x L)

25 mm x 482.6 mm

Measurement method

Reagentless, electrochemical, three-electrode amperometric system

Calibration methods

1-point or 2-point (zero and slope) calibration

Material

Corrosion-resistant, fully-submersible (stainless steel, PVC, silicon rubber and polycarbonate)

Warranty

1 year on the electrode body

Panel (including SS panel, gateway, chlorine sensor flow cell, pH sensor flow cell)

Operating temperature

0 to 50 °C

Power requirements

12 V DC, 30 mA maximum (supplied by sc controller)

Connections

6 mm OD

(pH Flow Cell Outlet): 12 mm OD

Panel dimensions

495.3 mm x 482.6 mm x 151.2 mm

Weight

Approximately 5.5 kg (panel and empty panel-mounted components only)

Controller platform

SC controller

Waterproof rating

IP65 (NEMA 4X)

Certification

CE / ETL, EMC

* Reference measurement must be conducted at the sensor sampling point.

Subject to change without notice.

CLT10 sc / CLF10 sc: Total and free reagentless chlorine sensors

Principle of operation

Amperometry is an electrochemical technique that measures the change in current resulting from chemical reactions taking place on the electrodes. The generated current is proportional to the analyte concentration. A typical amperometric sensor consists of two dissimilar electrodes; an anode and a cathode (i.e. silver/platinum or copper/gold, respectively).

Typically, the electrodes are covered with a membrane cap containing electrolyte, providing for better selectivity of the analysis. Additionally, a small constant electrical voltage is applied across the electrodes.

On the right hand side is a general schematic of the reduction oxidation reaction taking place in a simple 2-electrode amperometric system:

Cathode (working electrode):
 $\text{HOCl} + \text{H}^+ + 2\text{e}^- \rightarrow \text{Cl}^- + \text{H}_2\text{O}$
(reduction of hypochlorous acid)

Anode (reference electrode):
 $\text{Cl}^- + \text{Metal} \rightarrow \text{Metal-Cl} + \text{e}^-$
(oxidation of the anodic material)

In a three electrode amperometric system, such as used in the CLT10 sc and CLF10 sc, the anode is essentially split into two parts; a reference and an auxiliary (or counter) electrode. These systems are always supported by special electrical circuit directing the voltage between all electrodes. The three electrode design generally makes the measurements more stable and provides longer life for the working and reference electrodes.

Dimensions

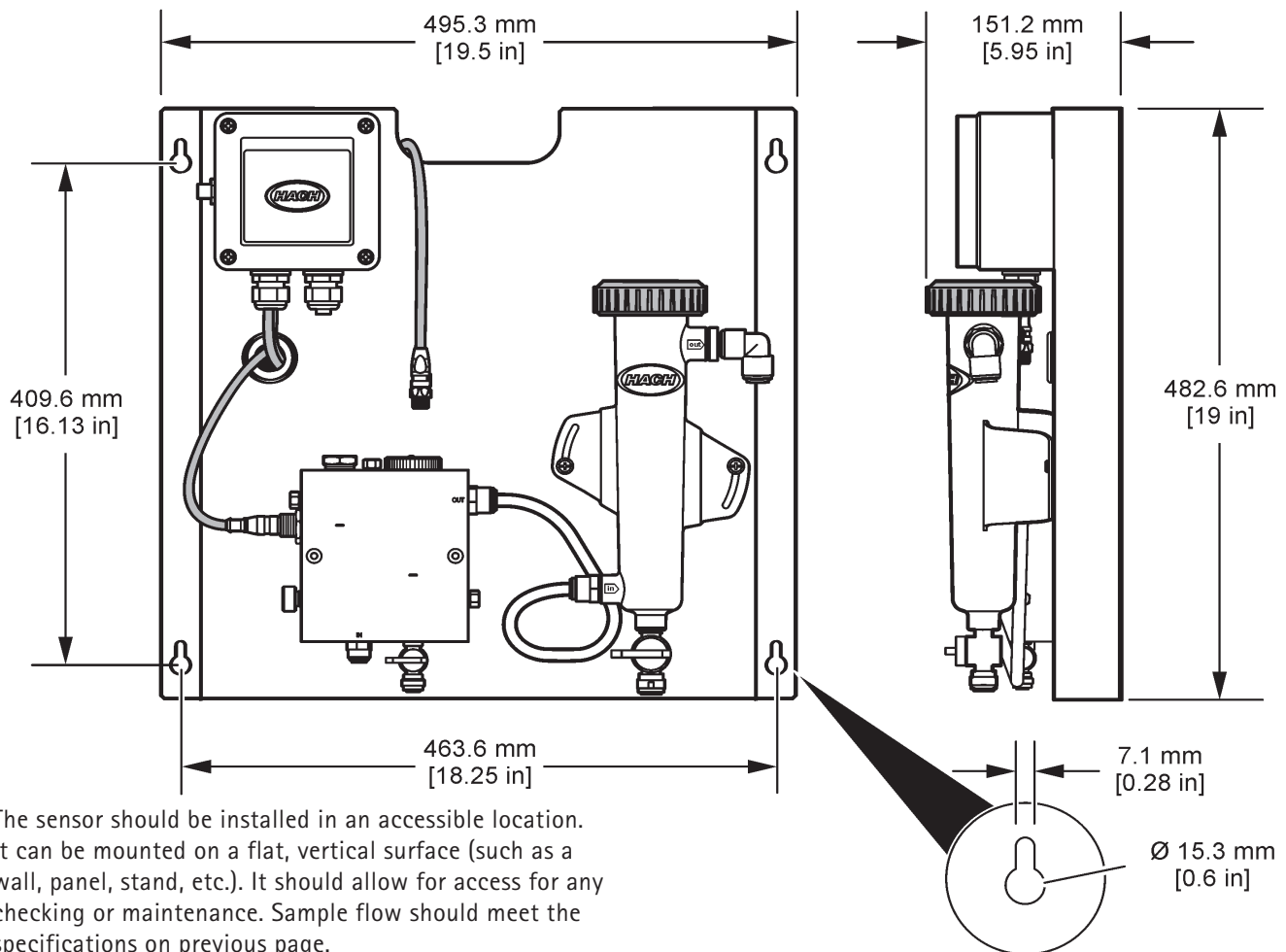

The sensor should be installed in an accessible location. It can be mounted on a flat, vertical surface (such as a wall, panel, stand, etc.). It should allow for access for any checking or maintenance. Sample flow should meet the specifications on previous page.

CLT10 sc / CLF10 sc: Total and free reagentless chlorine sensors

Order information and accessories

CLT10 sc total chlorine sensors

Article number	Product name	Product description
LXV45B.98.23022	CLT10 sc	Total chlorine sensor with pHD differential sensor (on panel)
LXV45B.98.22022	CLT10 sc	Total chlorine sensor with pH combination sensor (on panel)
LXV45B.98.21022	CLT10 sc	Total chlorine sensor with grab sample (on panel)

CLF10 sc free chlorine sensors

Article number	Product name	Product description
LXV45A.98.23022	CLF10 sc	Free chlorine sensor with pHD differential sensor (on panel)
LXV45A.98.22022	CLF10 sc	Free chlorine sensor with pH combination sensor analogue (on panel)
LXV45A.98.21022	CLF10 sc	Free chlorine sensor with grab sample (on panel)

Controllers

Article number	Product name	Product description
LXV401.99.XXXX1	SC 100	Digital dual-channel controller
LXV402.99.XXXX1	SC 1000	Digital multi-channel controller, display module
LXV400.99.XXXX1	SC 1000	Digital multi-channel controller, probe module

Accessories

Article number	Product description
LZY051	Acidification/cleaning unit for amperometric sc sensors
9159900	Sample conditioning kit, with two pressure regulators
9181505	pHD differential analogue pH sensor, Ryton
9181605	pH combination sensor, analogue, Ryton

Service options

Article number	Product description
TSE-COM-CL-10	Commissioning CLF10 sc / CLT10 sc sensor
TSE-MC-CL-10	One-off Service CLF10 sc / CLT10 sc
TSE-BC-CL-10	Basic Contract CLF10 sc / CLT10 sc
TSE-CC-CL-10	Extended Warranty Contract CLF10 sc / CLT10 sc

HACH LANGE has the broadest range of disinfection monitoring systems:



SC 1000 Controller (see above):
Up to eight out of 40 + different sensors covering 14 parameters can be connected to one controller. SC 1000 controllers can also be networked together, handling a maximum of 24 sensors at the same time. The multi talent with graphic and touch display for process management and communication.



CL17 chlorine analyser
(5440001 free chlorine / 5440002 total chlorine):
The CL17 is the market leader in chlorine analysis suitable for online chemical analysis solutions.



Pocket Colorimeter II (5953000V.02):
The colorimeter for chlorine analysis covers chemical laboratory applications and is suitable for DPD and Method 334.0.

For more information please visit our website!

DOC053.52.35006.May10



UNITED FOR WATER QUALITY