

## The Centec Group

Centec is a privately owned group of companies. Our automated process skids are used throughout the entire brewing process. For soft drinks, dairy and food industries we offer a large variety of skid mounted systems. We have decades of experience in water purification and deaeration, carbonation, liquid blending and dosing, flash pasteurization and cleaning-in-place. Centec technology includes a range of high precision process sensors for accurately measuring critical product properties such as extract, alcohol, milk fat, O<sub>2</sub> and CO<sub>2</sub>. The largest brewery, soft drink, dairy and food groups in the world are among our key customers.

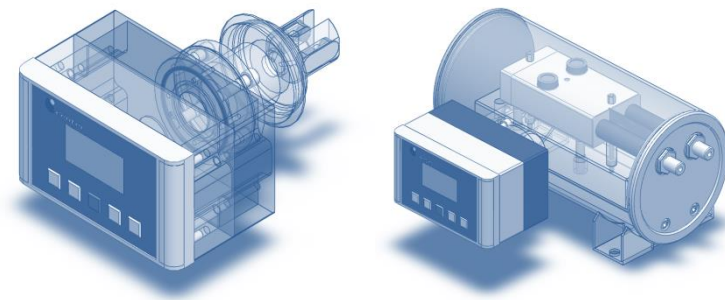

**Accuracy. Reliability. Centec.**

**Germany**  
Centec GmbH  
Wilhelm-Röntgen-Strasse 10  
63477 Maintal  
Tel.: +49 6181 18 78 0  
Fax: +49 6181 18 78 50  
info@centec.de

**Czech Republic**  
Centec automatika s.r.o.  
Pekařská 8/601  
155 00 Praha 5  
Tel.: +420 257 084 111  
Fax: +420 235 518 701  
prodej@centec.cz

**USA**  
Centec LLC  
P. O. Box 820  
Germantown, WI 53022-0820  
Tel.: +1 262 251 8209  
Fax: +1 262 251 8376  
info@centec-usa.com

**UK**  
Centec UK  
Stalworths, The Street  
Great Tey, Colchester, Essex, CO6 1JS  
Tel.: +44 1206 21 19 21  
Fax: +44 1206 21 19 16  
info@centec-uk.com

**Serbia**  
Centec Serbia  
Bogdana Žerajića 34/III  
11000 Beograd  
Tel.: + 381 11 358 11 24  
Fax: + 381 11 358 11 24  
info@centec.rs

**Hyxo Oy**  
P.O. Box 16 (Palokorvenkatu 2)  
FI-04261 Kerava, Finland  
Tel. +358 10 417 4500  
hyxo@hyxo.fi • www.hyxo.com

**India**  
Centec RRR Systems & Sensors Pvt Ltd  
RRR House, Plot 80, Sector 23  
Turbhe Naka, Navi Mumbai - 400 705  
Tel.: +91 22 2783 3655 & 2783 1348  
Fax: +91 22 2783 4814  
mail@centecrrr.com

**Brazil**  
Centec América Latina Ltda  
Largo de Sao Francisco de Paula nº 26  
Centro Cep. 20051 070 Rio de Janeiro  
Tel.: +55 21 2223 2066  
Fax: +55 21 2223 0324  
centeclatina@terra.com.br

# DeCarbonator

## Carbonation & Decarbonation

### Centec Beverage Systems



Automated  
process skids  
and high precision  
sensors from a  
single source.  
**Centec.**

# DeCarbonator

## The Principle

The Centec DeCarbonator is used for the carbonation, decarbonation and deoxygenation of beverages like beer, cider, soft drinks and sparkling water. Highly effective membrane contactors are applied in order to reach exactly the required value of residual CO<sub>2</sub> and O<sub>2</sub>. Each contactor contains thousands of microporous hydrophobic hollow fibre membranes. Their large internal surface maximizes the contact area between liquid and gas. While N<sub>2</sub> or CO<sub>2</sub> is applied on the inside of the hollow fibres, the beverage flows in counter current on the outside. Depending on the partial pressure difference of CO<sub>2</sub> between the liquid and the gas phase, the CO<sub>2</sub> permeates through the membranes into or out of the liquid. At the same time the O<sub>2</sub> content of the beverage is reduced. This fundamental scientific principle is described by "Henry's Law". At the outlet of the system the CO<sub>2</sub> content is permanently measured with a highly reliable CARBOTEC sensor developed and manufactured by Centec. Based on this accurate in-line measurement, the CO<sub>2</sub> flow is instantly and fully automatically adjusted. The modular design of the process units allows for easy expansion, e.g. for carboblending or additional nitrogenation.

## Technical Data

Capacity	10 - 1.500 hl/h
Range of CO <sub>2</sub>	0 - 10 g/l or 0 - 5 vol.%
Range of CO <sub>2</sub>	0 - 10 g/l or 0 - 5 vol.%
Pressure of Operation	0 - 6 bar
Temperature of Operation	2 - 20 °C
Temperature of CIP	up to 85 °C
Material	1.4301/1.4404 AISI 304/316L
PLC	SIMATIC S7
Options	in-line measurement of O <sub>2</sub> /CO <sub>2</sub> /sugar/alcohol/... nitrogenation blending

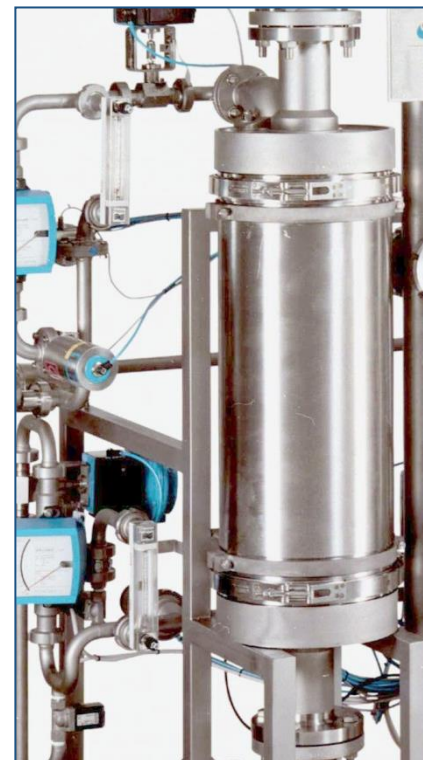

- **Application Specific and Energy Efficient**  
exceptional accuracy with CARBOTEC sensor technology  
membrane contactors for increase or decrease of CO<sub>2</sub>  
carboblending or additional nitrogenation on demand
- **Modular Design with Standard PLC**  
skid mounted for easy installation and start-up
- **Hygienic Execution and Full CIP Capability**
- **Outstanding Price-Performance-Ratio**

## Experience. Expertise. Centec.

*Ion Exchange · Reverse Osmosis · Membrane Deaeration · Column Deaeration · Hops Pre-Isomerization  
Wort Aeration · Yeast Pitching · Nitrogenation · Carbonation · Carboblending · High Gravity Blending  
Multi Component Mixing · Additive Dosing · Flash Pasteurization · Cleaning-in-Place · Dealcoholization*

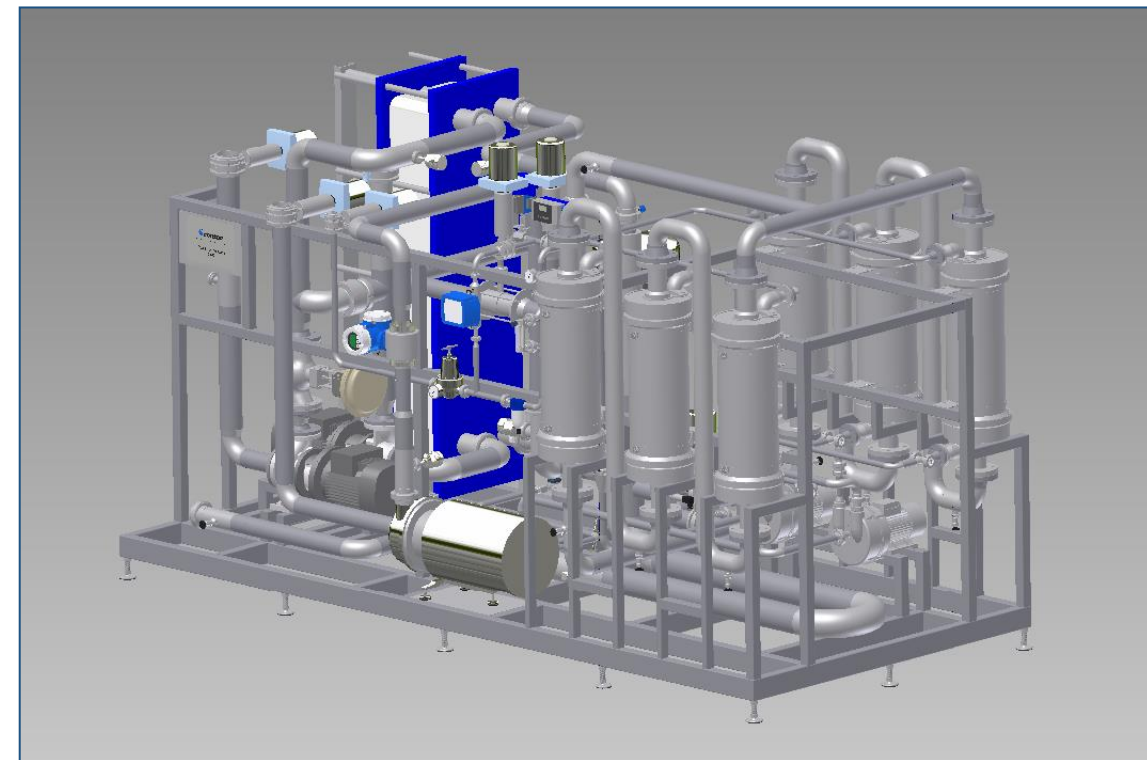

The Centec production is certified according to ISO 9001.