

SEEPEX.
ALL THINGS FLOW

YOUR PUMPING SOLUTION FOR HARSH APPLICATIONS PRODUCT GROUP T BTEX RANGE

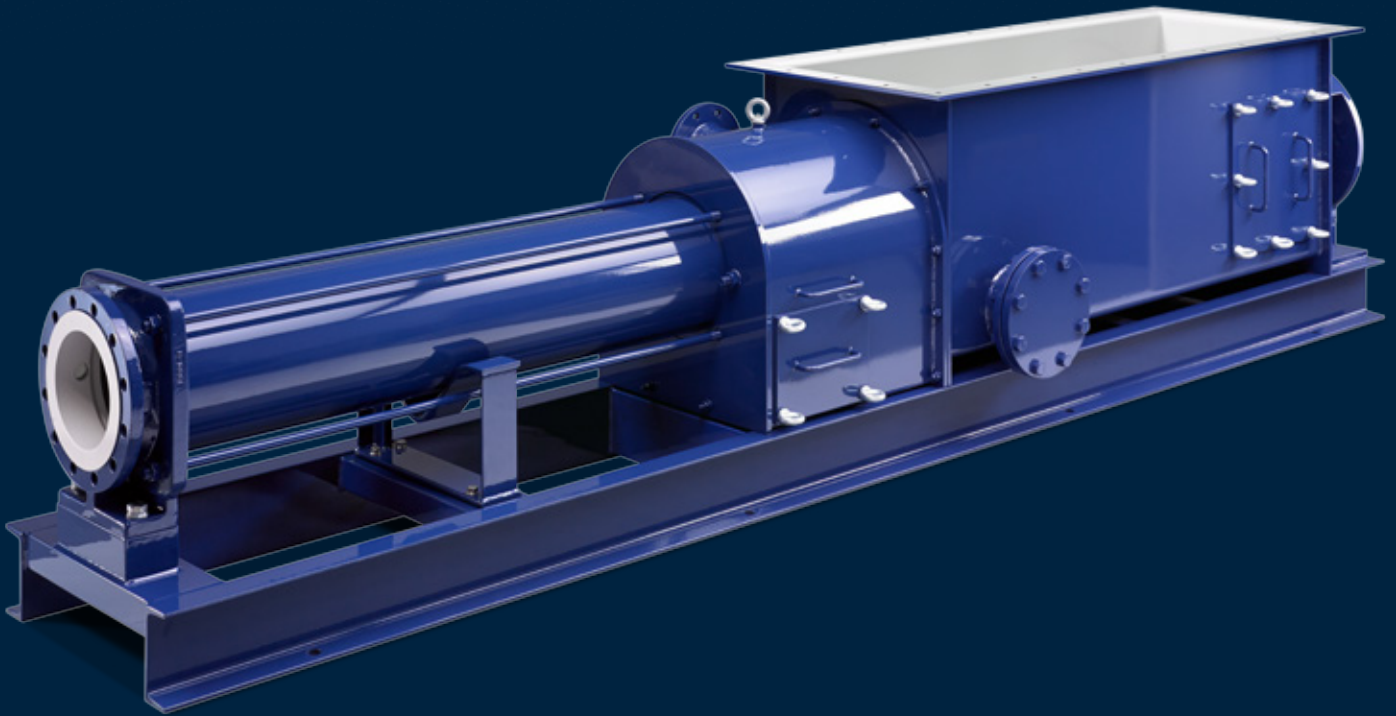

T – OPEN HOPPER PUMPS BTEX RANGE.

SEEPEX BTEX range progressive cavity pumps with their robust design and reinforced components are used in extreme conveying applications in the agriculture and biogas industries. In these applications, the conveyed products can contain solids like stones, pieces of wood or metal parts. During the pumping process this debris is separated from the media in the hopper/compression housing unit and can be easily removed via the large inspection openings.

A significant feature is the removable compression housing, which greatly simplifies maintenance. Depending on the application, the connections in the hopper and the compression housing can be used for feeding the liquid phases.

Available options include dry running protection, pressure monitoring and level control.

FLANGE CONNECTION

Flange for feeding liquids.

ROBUST JOINT PROTECTION WITH CONVEYING FLIGHTS

Protects the joint from damage and penetration of fibrous foreign solids. Additional blade ensure optimum product infeed.

COMPRESSION HOUSING

Acts as a solids separator for removing foreign objects and is easily removable for quick and easy maintenance.

SCREW CONVEYOR

High flow screw auger for thorough mixing and optimum product infeed via a special pitch and solid conveying flights.

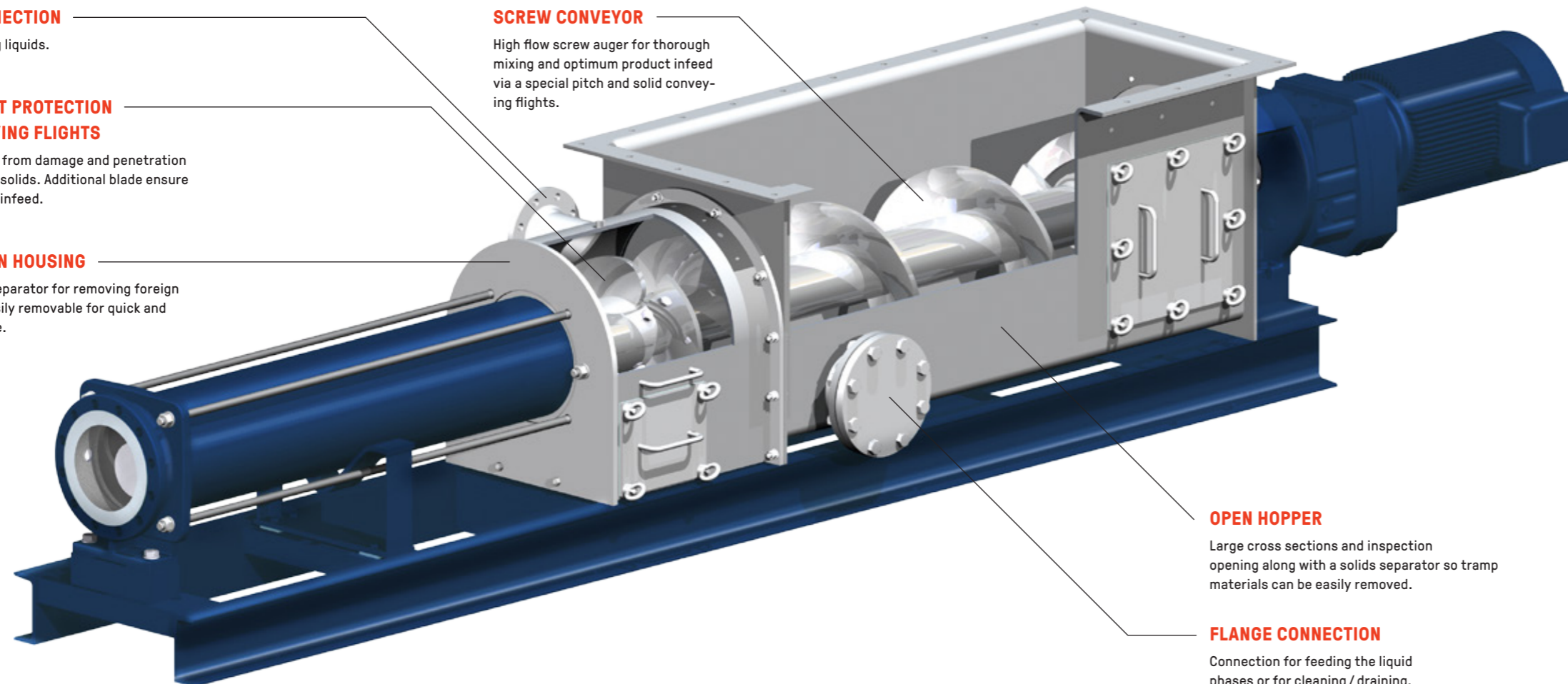

OPEN HOPPER

Large cross sections and inspection opening along with a solids separator so tramp materials can be easily removed.

FLANGE CONNECTION

Connection for feeding the liquid phases or for cleaning / draining.

WHY A SEEPEX BTEX PUMP?

PROPERTIES AND BENEFITS

- Robust components for harsh applications
- Large cross sections
- Foreign solids are separated within the special hopper design
- Large inspection openings allow for easy removal of any separated solids

- The high volume feed auger promotes thorough mixing of solid and liquid fermentation products
- Removable compression housing ensures quick and easy maintenance

KEY FACTS

- Conveying capacity: 20–80 m³/h (90–350 USGPM)
- Pressure: up to 8 bar (120 psi)



We are a member of the German Biogas Association and the ADBA, Anaerobic Digestion and Biogas Association, UK.

SEEPEX.
ALL THINGS FLOW

SEEPEX GmbH
www.seepex.com

Hyxo Oy PL 16 (Palokorvenkatu 2), 04261 Kerava • puh. 010 417 4500 • hyxo@hyxo.fi • www.hyxo.fi