

SEEPEX.
ALL THINGS FLOW

TO EXACTING STANDARDS PRODUCT GROUP N BNA RANGE, API 676

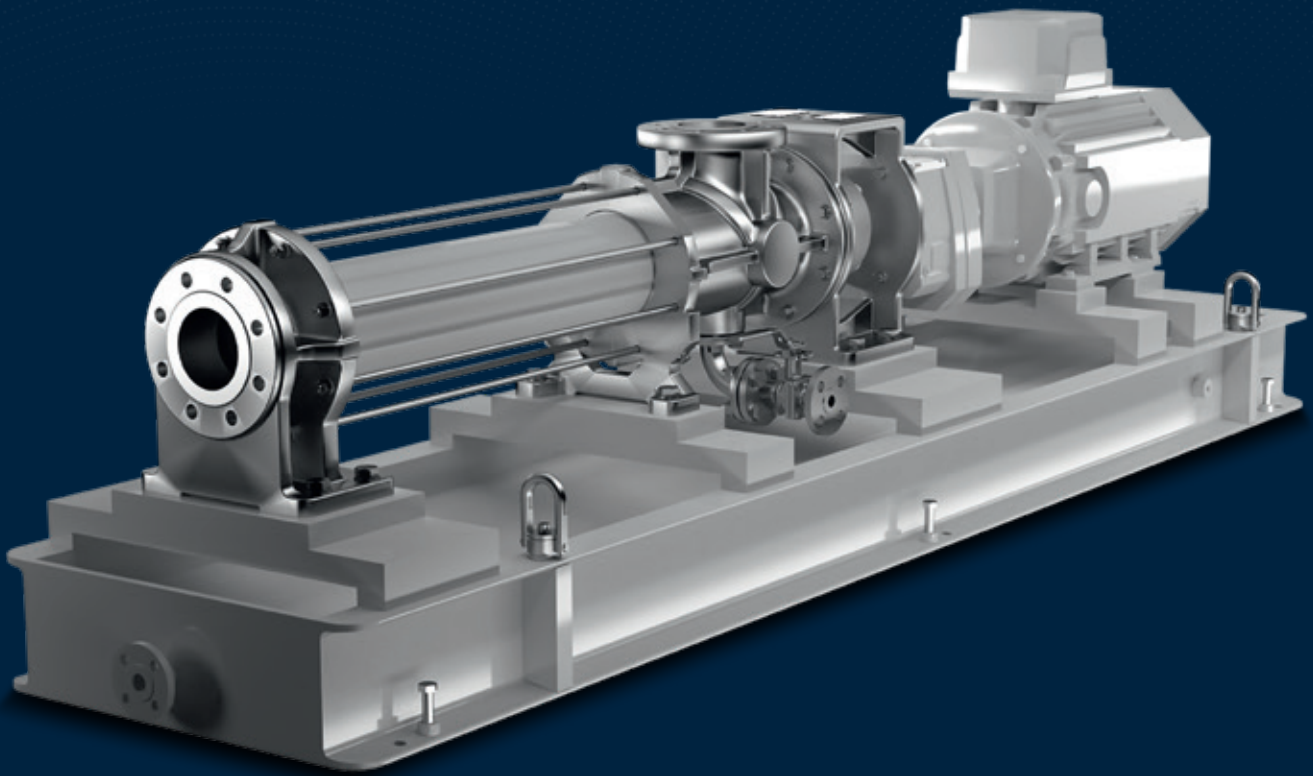

BNA

API COMPLIANT.

SEEPEX progressive cavity pumps from the BNA range are designed to fulfill the exacting requirements of the Oil & Gas Industry and meet American Petroleum Institute (API) standards.

BNA range pumps have rugged, heavy-duty castings in accordance with API 676 3rd Edition and casing parts made of super duplex stainless steel.

The maximum containment pressure for both suction and discharge is 50 bar. The flanges are according to ASME B16.5 – suitable for two times the external forces and moments required by API 676.

Additionally, SEEPEX offers fully API 682 compliant mechanical seals with optimized seal plans. ASTM materials, full traceability and compliance with NACE MR0175 are standard features. The pump can also be designed for gas hazardous areas.

WHY A SEEPEX API PUMP?

BENEFITS

- All process parts are cast or machined – no welding required
- Reduced number of documents and fewer inspections
- API compliant
- Heavy duty design
- Standardized pump components
- Favorable lead time

OPTIONAL

- Casing items available with NORSOK qualification
- Motors acc. to IEEE841/NEMA
- Seal plans optimized for use with a progressive cavity pump
- Dry-running protection device
- Supply of pressure limiting valve acc. to API 520 & API 526

KEY FACTS

- Conveying capacity: 0.1–150 m³/h (0.44–660 USGPM)
- Working pressure (MAWP): up to 48 bar (700 psi)
- Casing pressure (MACP): up to 50 bar (725 psi)

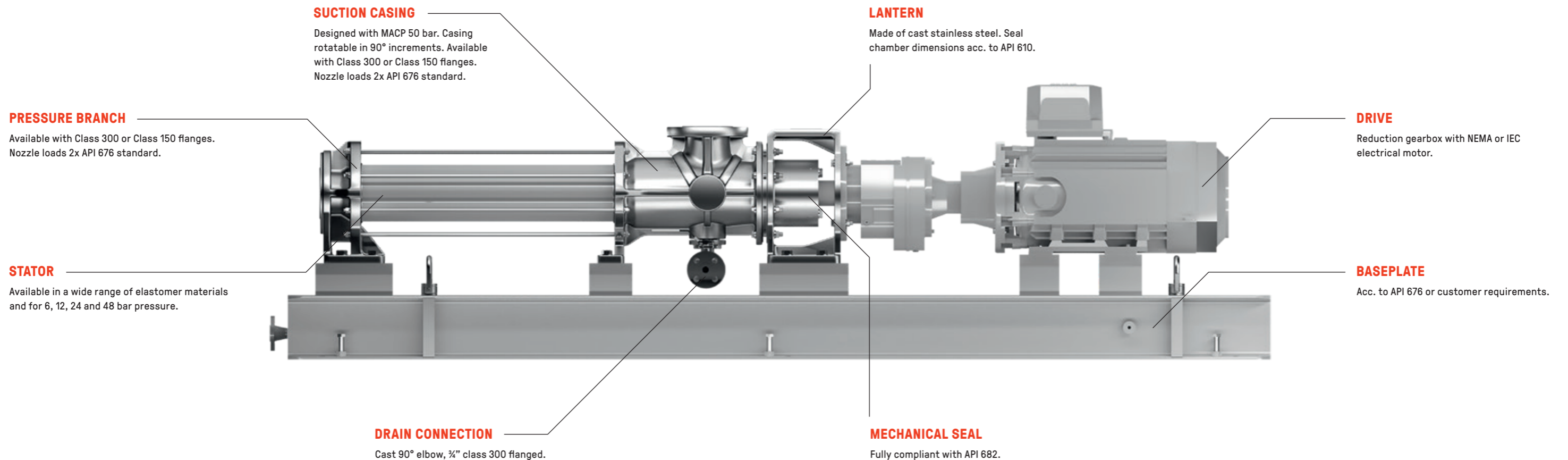

SEEPEX.
ALL THINGS FLOW

SEEPEX GmbH
www.seepex.com

HyXo Oy PL 16 (Palokorvenkatu 2), 04261 Kerava • puh. 010 417 4500 • hyxo@hyxo.fi • www.hyxo.fi