



GS SERIES

WET PRIME CENTRIFUGAL PUMPS

The GS Series lineup from Pioneer is the next generation of self-priming pumps. By utilizing the best materials coupled with reliable construction, these heavy-duty pumps are designed to handle solids and clear liquids while providing exceptional performance and reliability.





GS SERIES

Designed for handling solids and clear liquids, the Pioneer GS Series is the next generation of self-priming pumps. This lineup of pumps offer superior performance, increased reliability, and additional ease-of-maintenance features.

FEATURES

- Rotating assembly utilizes a double-lip seal with atmospheric drain for additional bearing protection
- Simple, external shimless impeller adjustment from either the rotating assembly or cover plate allows for increased wear life and ease of adjusting tolerances
- Removable cover plate with convenient grip handle for ease of maintenance; incorporates jack bolts for aiding in removal
- Cartridge-type, oil-lubricated tungsten versus silicon carbide mechanical seal for simple installation and ease of maintenance
- 17-4 PH stainless steel shaft is corrosion-resistant, easy to maintain, and highly reliable
- Standard, heavy-wall volute for durability and peace of mind
- Semi-open, trash-handling, dynamically-balanced ductile iron impeller
- FKM O-rings allow for use in a wide range of applications
- Available in other alloys, including 316 and CD4MCu stainless steels



MARKETS

- Industrial
- Municipal
- Construction
- Oil Field
- Agricultural
- Food Processing
- Wastewater
- Mining
- Petrochemical

AVAILABLE MATERIALS

- Cast Iron
- 316 SS
- CD4MCu SS
- 304 SS
- ADI

DRIVE OPTIONS

- Bareshaft Pump End
- Overhead Belt Drive
- Electric Driven Trailer
- Diesel Driven Trailer
- Electric Direct Drive w/ Guard

PUMP SPECIFICATIONS

Model Number	GS3087L75-HO	GS4097L75-HO	GS6012L75-HO	GS8014L75-HO	GS10014L75-HO
Size (Connection)	3" x 3" (76 x 76 mm)	4" x 4" (102 x 102 mm)	6" x 6" (152 x 152 mm)	8" x 8" (203 x 203 mm)	10" x 10" (254 x 254 mm)
Max Flow	490 usgpm (111 m ³ /h)	800 usgpm (181 m ³ /h)	1500 usgpm (340 m ³ /h)	2500 usgpm (567 m ³ /h)	3450 usgpm (783 m ³ /h)
Max Head	140 ft (42 m)	112 ft (34 m)	115 ft (35 m)	130 ft (39 m)	175 ft (53 m)
Solids Handling	2.5" (63.5 mm)	3" (76 mm)	3" (76 mm)	3" (76 mm)	3" (76 mm)
Efficiency at BEP	47%	47%	47%	59%	76%

GS SERIES

PERFORMANCE

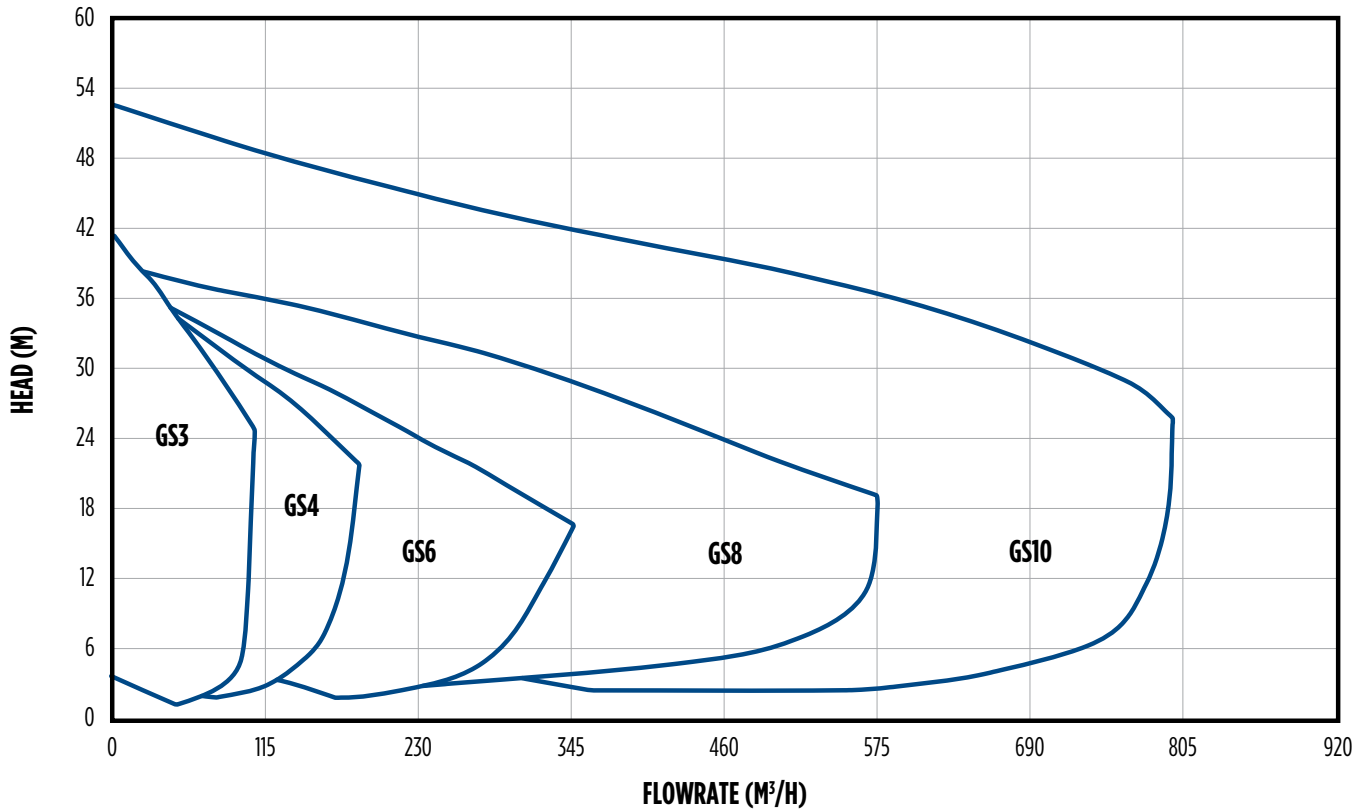

CONSTRUCTION

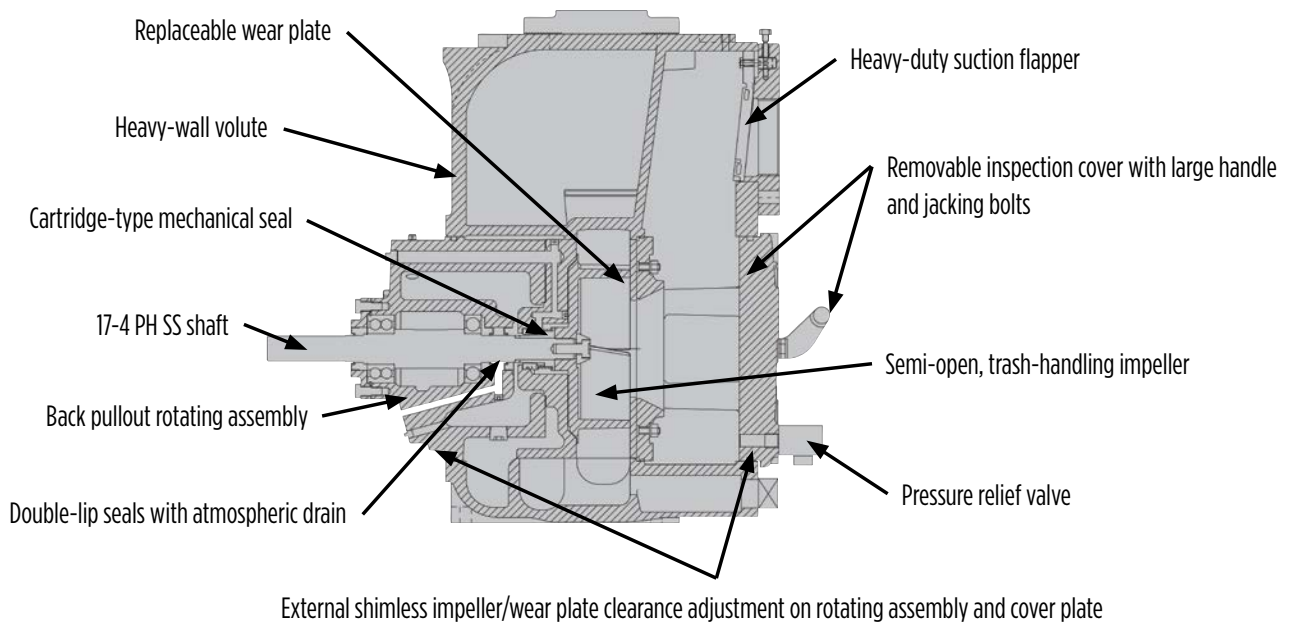



pioneerpump.com

M5125 04-18