



# **BLAGDON PUMP®**

A Warren Rupp, Inc. Brand

**PROVEN  
PERFORMANCE  
RELIABLE PUMPING  
SOLUTIONS**





# ABOUT BLAGDON

## Our Background

Blagdon Pump was founded in the early 1950's in the North East of England as a specialist pump manufacturer. In 1979 production of **AIR OPERATED DOUBLE DIAPHRAGM PUMPS** commenced and we soon became a market leader. In 1997 the US based multinational IDEX Corporation acquired Blagdon Pump to strengthen their global position in the double diaphragm market. Blagdon Pump transferred operations to Ireland in 2009. Blagdon Pump is dynamic and evolving. Our aim is to make dealing with us an easy and efficient experience – a service you can rely on for all your pump requirements.

## Our Mission

Blagdon AODD pumps provide high performance, reliable solutions for your pumping needs. We specialise in extreme condition environments and applications, keeping your process moving both above and below ground.

## Our Website

We are committed to offering you a dedicated sales and after sales service which is second to none. Now you can keep up to date with developments as they happen with our website, [www.blagdonpump.com](http://www.blagdonpump.com). We look forward to working with you.

## Blagdon Certifications



ATEX



GOST-R



EHEDG



CE



FDA

**NEW**

## AIRVANTAGE - Energy Saving Technology

AirVantage is a new technology for Air Operated Double Diaphragm pumps that significantly reduces air consumption over conventional AODD pumps.

### Conventional

AODD pumps fully expand diaphragms to complete pump stroke, causing increased air usage and expense.

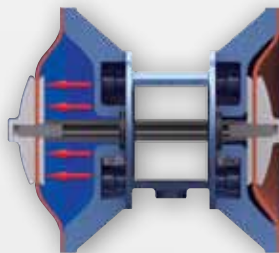

VS.

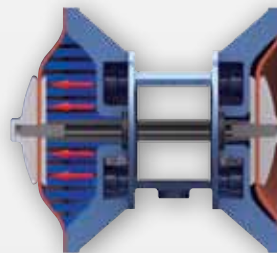

Uses advanced technology to complete full diaphragm expansion using up to 50% less air while maintaining flow.

## Benefits of AirVantage

- Reduces air consumption
- Adapts to process conditions
- Powered only by compressed air
- Saves energy while maintaining flow
- Increases productivity
- Reduces compressor maintenance

Visit the Blagdon AirVantage website at [www.airvantagepump.com/blagdon](http://www.airvantagepump.com/blagdon) to learn more about this award winning technology.

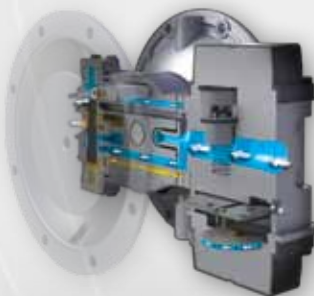



Air operated double diaphragm pumps have long been recognised as the “work horse” of the industry for handling difficult liquids at relatively low pressures and flows. The range of applications is virtually limitless. Blagdon AODD pumps come in many sizes and choices of materials of construction. Almost every type of liquid from highly corrosive acids through high viscosity paints and adhesives, to food and drink products can be pumped.

Blagdon 1/2", 1" and 2" EHEDG approved hygienic pumps in polished 316L stainless steel



Blagdon 1/2", 1", 1 1/2" and 2" FDA compliant pumps in polished steel plus assorted standard fluid fittings



Blagdon 1" and 2" high pressure 2:1 pumps available in aluminum, stainless steel



Blagdon metallic pumps available in aluminum, cast iron, stainless steel from 1/4" to 3"



Blagdon non-metallic pumps available in conductive polypropylene, and kynar (PVDF) from 1/4" to 2"



100 PSI (7 Bar)

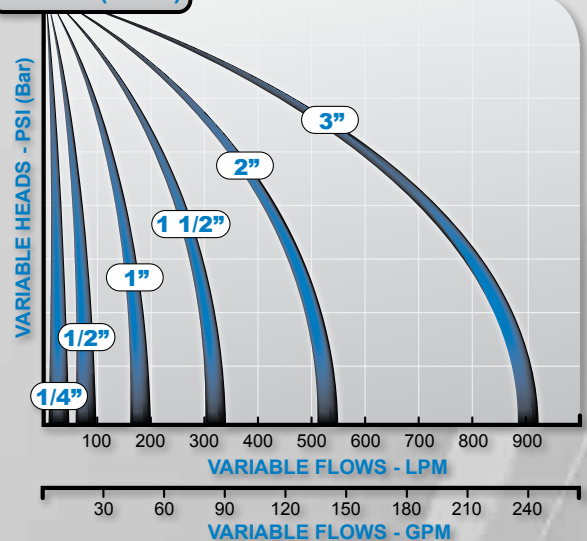

Individual specification sheets available for download at [www.blagdonpump.com](http://www.blagdonpump.com)



# BLAGDON BENEFITS

Blagdon offers an extensive pump range for handling fluid media safely and cost effectively. We offer low cost ownership, by combining high quality wear parts with low price spares and a vast array of accessories. A flexible modular design of pumps means we can offer short lead times and high degree of customising opportunities. Our experienced staff can provide instant support for installation, servicing, maintenance or a technical enquiry. We offer a fast spares delivery service, with many items in stock for immediate delivery.

## Key features and benefits of a Blagdon Pump

- Can run dry without damage or heat build up
- Fully submersible
- Designed to operate at low noise levels
- Leak-free air valves, easily removed for servicing
- Easily maintained – Stripped down quickly without any specialist tools
- Self priming to over 6 metres (19.7 Feet)
- Can safely “dead head” against closed discharge
- Low degradation and minimum product agitation
- Low start up pressures
- Portable and compact – can be remotely controlled
- Safe in hazardous areas – No sparking – Air-driven



## How the air-operated, double diaphragm pump operates

The Pump Chambers are alternatively filled and emptied by drawing fluid in through a common (suction) inlet (C), and out through a common (discharge) outlet (D). The diaphragms in each chamber are linked by a common shaft, so that they move backwards and forwards in unison. Compressed air is directed by the air valve alternatively, behind each diaphragm, to power discharge strokes. Pump speed, fluid output and pressure (or head) is controlled by increasing or decreasing the flow of compressed air to the pump.

## Operation Sequence

### Suction Cycle:

Fluid is drawn into the suction manifold at (C), by the suction stroke of the diaphragm and into chamber (B).

This ‘opens’ the ball valve (2) to allow liquid to enter the chamber. Ball valve (4) is drawn into the valve seat and ‘closed’ by the diaphragm suction stroke.

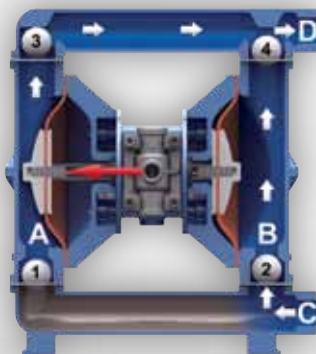

### Discharge Cycle:

In chamber (A), air has been applied to the rear of the diaphragm to force out the fluid in the chamber through the ball valve (3) to the discharge manifold (D).

The discharge stroke ‘closes’ the ball valve (1) to prevent further liquid entering the chamber.

This cycle is repeated to provide a continuous flow to the discharge manifold at outlet (D).

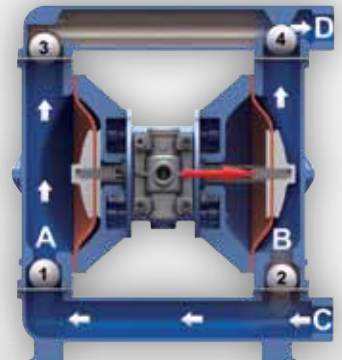



A full list of chemicals and recommended elastomers is available on request, or our sales office can advise on the best pumps and materials for specific media.

### Typical range of products you can pump.

- **ABRASIVES:** Clay slip, titanium dioxide, mill scale
- **ACIDS:** All mineral and organic acids
- **ADHESIVE:** Solvent and water based
- **ALCOHOLS:** Chemicals
- **CAUSTICS:** Acids
- **CEMENT:** Slip, glazes, clay
- **COSMETICS:** Creams, emulsions, detergents
- **DRILLING:** Mud, grout, lubricants
- **DRINKS:** Soft drinks, spirits, beer, wine, milk
- **EXPLOSIVES:** Suspensions of gun powder, explosives, etc.
- **FOODS:** Liquid and semi-solid foods, flavourings
- **INKS & DYES:** Printing inks, dyes, sizes and solvents
- **OILS:** Petrol, diesel, hydraulic, and cutting oils, lube oils, animal and vegetable oils and greases
- **PAINT:** Emulsions, latexes, pigments, solvents, resins, thinners
- **PHARMACEUTICALS:** Liquids, creams, and compounds
- **PLATING:** Aggressive acids, salts, sludge and effluents
- **PULPS:** paper, wood, sizes, bleaches
- **RESINS:** Natural and synthetics, water and solvent based, monomeric and polymeric plastics
- **RUBBER:** Gum, latex
- **SLUDGE & WASTE:** Sewage, effluents, coal and lime slurry
- **SOLVENTS:** Aromatic and aliphatics, ketones, aldehydes, esters and chlorinated hydrocarbons, de-icing fluids
- **TIMBER PRESERVATIVES:** Creosote, turpentine, copper naphthenate
- **WATER:** All types

<p style="text-align: center;"><b>Self Priming</b></p>	<p style="text-align: center;"><b>Filling / Injection / Dosing</b></p>
<p style="text-align: center;"><b>Submerged Operation</b></p>	<p style="text-align: center;"><b>Flooded Suction</b></p>
<p style="text-align: center;"><b>Permanent or Portable Options</b></p>	<p style="text-align: center;"><b>Safe for Hazardous Areas</b></p>

## Pump Duties

Blagdon pumps can be installed in any of the models illustrated to perform the following duties: Liquid Transfer, Slurry Handling, Filter Feeding, Circulation, De-watering, Low Pressure, Spray Supply, Tank/Sump/Barrel/Drum Filling and Emptying, Batching/Mixing/Metering/Dosing, and Chemical Injection, etc.



# PORTFOLIO INFORMATION

 <b>Blagdon</b> <b>Portfolio Information</b>	Pump Model/Size/Material	Fluid Contact Materials								Air Chamber Materials					Diaphragm										
		Conductive PTFE	Virgin PTFE	Aluminium	Cast Iron	PVDF	Polypropylene	Conductive Polypropylene	Stainless Steel	Polished Stainless	Aluminium	Cast Iron	Nickel Plated Aluminium	Polypropylene	Stainless Steel	Epoxy Coated Aluminium	Epoxy Coated Stainless Steel	Conductive PTFE	PTFE Coated Aluminium	Buna-N	EPDM (Inc. Food Grade)	Geolast	Polyester (Hytel)	Neoprene	
Metallic Pumps (Ball Valve)	B06 - 1/4" Stainless Steel							•							•					•	•	•	•		
	B15 - 1/2" Aluminium			•							•										•	•	•	•	
	B15 - 1/2" Stainless Steel								•						•						•	•	•	•	
	B25 - 1" Aluminium			•								•									•	•	•	•	
	B25 - 1" Cast Iron				•							•									•	•	•	•	
	B25 - 1" Stainless Steel								•			•			•						•	•	•	•	
	B40 - 1 1/2" Aluminium			•								•									•	•	•	•	
	B40 - 1 1/2" Cast Iron				•							•									•	•	•	•	
	B40 - 1 1/2" Stainless Steel								•			•				•					•	•	•	•	
	B50 - 2" Aluminium			•								•									•	•	•	•	
	B50 - 2" Cast Iron				•							•									•	•	•	•	
	B50 - 2" Stainless Steel								•			•			•						•	•	•	•	
	X75 - 3" Aluminium			•								•				•					•	•	•	•	
	X75 - 3" Cast Iron				•							•									•	•	•	•	
X75 - 3" Stainless Steel								•			•				•					•	•	•	•		
Non-Metallic Pumps (Ball Valve)	B06 - 1/4" Polypropylene					•								•						•	•	•	•		
	B06 - 1/4" PVDF						•							•							•	•	•	•	
	B10 - 3/8" Polypropylene					•								•							•	•	•	•	
	B15 - 1/2" Polypropylene						•	•	•						•	•					•	•	•	•	
	B15 - 1/2" PVDF					•									•	•					•	•	•	•	
	B25 - 1" Polypropylene						•	•							•	•					•	•	•	•	
	B25 - 1" PVDF					•									•	•					•	•	•	•	
	B50 - 2" Polypropylene						•	•							•	•					•	•	•	•	
	B50 - 2" PVDF					•									•	•					•	•	•	•	
	B75 - 3" Polypropylene						•		•						•	•			•			•	•	•	•
B75 - 3" PVDF					•									•	•			•			•	•	•	•	
Metallic Pumps (Flap Valve)	X25 - 1" Aluminium			•							•									•	•	•	•		
	X25 - 1" Cast Iron				•						•										•	•	•	•	
	X25 - 1" Stainless Steel								•		•										•	•	•	•	
	X50 - 2" Aluminium			•								•									•	•	•	•	
	X50 - 2" Cast Iron				•							•									•	•	•	•	
	X50 - 2" Stainless Steel								•		•				•						•	•	•	•	
	X75 - 3" Aluminium			•								•									•	•	•	•	
	X75 - 3" Cast Iron				•							•									•	•	•	•	
	X75 - 3" Stainless Steel								•			•				•					•	•	•	•	
	AVB75 / AVX75 - Aluminum Air Vantage						•					•									•	•	•	•	
	AVB75 / AVX75 - Cast Iron Air Vantage						•					•									•	•	•	•	
AVB75 / AVX75 - Stainless Steel Air Vantage						•					•									•	•	•	•		
Hygienic Pumps	B15 - 1/2" Hygienic								•			•			•						•	•	•	•	
	B25 - 1" Hygienic								•			•			•						•	•	•	•	
	B50 - 2" Hygienic								•			•			•						•	•	•	•	
High Pressure Pumps	B25 - 1" Standard 2:1			•	•						•		•								•	•	•	•	
	B25 - 1" Full Flow 2:1			•							•				•						•	•	•	•	
	B50 - 2" Full Flow 2:1			•							•				•						•	•	•	•	
FDA Pumps	B15 - 1/2" Stainless Steel								•			•									•	•	•	•	
	B25 - 1" Stainless Steel								•			•									•	•	•	•	
	B40 - 1 1/2" Stainless Steel								•			•									•	•	•	•	
	B50 - 2" Stainless Steel								•			•									•	•	•	•	
PTFE Pumps	B15 - 1/2" Conductive PTFE	•													•										
	B15 - 1/2" Virgin PTFE		•												•										
	B25 - 1" Conductive PTFE	•																•							
	B25 - 1" Virgin PTFE		•																						



Materials						Check Valve Materials						Max. Flow		Fluid Connections			Air Inlet	Max. Op Pressure		Max. Solid Size (mm)	
PTFE (One Piece)	Polyurethane	Santoprene	PTFE	Viton		Buna-N	EPDM (Inc. Food Grade)	Neoprene	Santoprene	Stainless Steel	PTFE	Viton	UKGPM	L/Min	BSP(F)	ANSI Flange	RJT(M)	BSP (NPT)F	Bar	PSI	
•	•	•	•	•	•	•	•	•	•	•	•	•	4	18	1/4"			1/4"	8.6	125	1
•	•	•	•	•	•	•	•	•	•	•	•	•	14	60	1/2"			1/4"	8.6	125	2
•	•	•	•	•	•	•	•	•	•	•	•	•	14	60	1/2"			1/4"	8.6	125	2
•	•	•	•	•	•	•	•	•	•	•	•	•	40	180	1"			3/8"	8.6	125	3
•	•	•	•	•	•	•	•	•	•	•	•	•	40	180	1"			3/8"	8.6	125	3
•	•	•	•	•	•	•	•	•	•	•	•	•	40	180	1"			3/8"	8.6	125	3
•	•	•	•	•	•	•	•	•	•	•	•	•	76	320	1 1/2"			3/8"	8.6	125	6
•	•	•	•	•	•	•	•	•	•	•	•	•	76	320	1 1/2"			3/8"	8.6	125	6
•	•	•	•	•	•	•	•	•	•	•	•	•	76	320	1 1/2"			3/8"	8.6	125	6
•	•	•	•	•	•	•	•	•	•	•	•	•	120	530	2"			3/4"	8.6	125	6
•	•	•	•	•	•	•	•	•	•	•	•	•	120	530	2"			3/4"	8.6	125	6
•	•	•	•	•	•	•	•	•	•	•	•	•	120	530	2"			3/4"	8.6	125	6
•	•	•	•	•	•	•	•	•	•	•	•	•	202	889	3"			3/4"	8.6	125	10
•	•	•	•	•	•	•	•	•	•	•	•	•	202	889	3"			3/4"	8.6	125	10
•	•	•	•	•	•	•	•	•	•	•	•	•	202	889	3"			3/4"	8.6	125	10
•	•	•	•	•	•	•	•	•	•	•	•	•	4	16	1/4"			1/4"	5	72	1
•	•	•	•	•	•	•	•	•	•	•	•	•	4	16	1/4"			1/4"	5	72	1
•	•	•	•	•	•	•	•	•	•	•	•	•	6	26	3/8"			1/4"	7	100	2
•	•	•	•	•	•	•	•	•	•	•	•	•	1	48		1/2" 150 RF		1/4"	8	116	2
•	•	•	•	•	•	•	•	•	•	•	•	•	1	48		1/2" 150 RF		1/4"	8	116	2
•	•	•	•	•	•	•	•	•	•	•	•	•	34	152		1" 150 RF		3/8"	8	116	3
•	•	•	•	•	•	•	•	•	•	•	•	•	34	152		1" 150 RF		3/8"	8	116	3
•	•	•	•	•	•	•	•	•	•	•	•	•	120	530		2" 150 RF		3/4"	8.6	125	6
•	•	•	•	•	•	•	•	•	•	•	•	•	120	530		2" 150 RF		3/4"	8.6	125	6
•	•	•	•	•	•	•	•	•	•	•	•	•	238	901		3" 150 RF		1"	6.9	100	18
•	•	•	•	•	•	•	•	•	•	•	•	•	238	901		3" 150 RF		1"	6.9	100	18
•	•	•	•	•	•	•	•	•	•	•	•	•	70	265	1"			1/2"	8.6	125	25
•	•	•	•	•	•	•	•	•	•	•	•	•	70	265	1"			1/2"	8.6	125	25
•	•	•	•	•	•	•	•	•	•	•	•	•	70	265	1"			1/2"	8.6	125	25
•	•	•	•	•	•	•	•	•	•	•	•	•	140	530	2"			3/4"	8.6	125	50
•	•	•	•	•	•	•	•	•	•	•	•	•	140	530	2"			3/4"	8.6	125	50
•	•	•	•	•	•	•	•	•	•	•	•	•	140	530	2"			3/4"	8.6	125	50
•	•	•	•	•	•	•	•	•	•	•	•	•	260	988		3" 150 RF		3/4"	8.6	125	80
•	•	•	•	•	•	•	•	•	•	•	•	•	260	988		3" 150 RF		3/4"	6.9	125	80
•	•	•	•	•	•	•	•	•	•	•	•	•	260	988		3" 150 RF		3/4"	6.9	125	80
•	•	•	•	•	•	•	•	•	•	•	•	•	238	901		3" 1 0 RF		1"	6.9	100	18
•	•	•	•	•	•	•	•	•	•	•	•	•	238	901		3" 1 0 RF		1"	6.9	100	18
•	•	•	•	•	•	•	•	•	•	•	•	•	238	901		3" 1 0 RF		1"	6.9	100	18
•	•	•	•	•	•	•	•	•	•	•	•	•	17	75			1"	1/4"	8.6	125	2
•	•	•	•	•	•	•	•	•	•	•	•	•	31	136			1"	3/8"	8.6	125	3
•	•	•	•	•	•	•	•	•	•	•	•	•	114	500			2"	3/4"	8.6	125	10
•	•	•	•	•	•	•	•	•	•	•	•	•	20	86	1"			1/4"	16	232	3
•	•	•	•	•	•	•	•	•	•	•	•	•	28	125	1"			3/8"	16	232	3
•	•	•	•	•	•	•	•	•	•	•	•	•	80	350	2"			3/4"	16	232	6
•	•	•	•	•	•	•	•	•	•	•	•	•	14	60	1/2"			1/4"	8.6	125	2
•	•	•	•	•	•	•	•	•	•	•	•	•	40	180	1"			3/8"	8.6	125	3
•	•	•	•	•	•	•	•	•	•	•	•	•	76	320	1 1/2"			3/8"	8.6	125	6
•	•	•	•	•	•	•	•	•	•	•	•	•	120	530	2"			3/4"	8.6	125	6
•	•	•	•	•	•	•	•	•	•	•	•	•	1	48		1/2" 150 RF		1/4"	7	100	2
•	•	•	•	•	•	•	•	•	•	•	•	•	1	48		1/2" 150 RF		1/4"	7	100	2
•	•	•	•	•	•	•	•	•	•	•	•	•	34	136		1" 150 RF		3/8"	7	100	3
•	•	•	•	•	•	•	•	•	•	•	•	•	34	136		1" 150 RF		3/8"	7	100	3



## Diaphragm & Ball Valve Options

- Uses, Temperature Limits & Specific Gravity

Elastomer	Main Properties and Uses	Operating Temperatures			Ball Valve S.G.	
		Min	Optimum	Max	Standard	Weighted
Buna-N	General purpose for use on water, most hydrocarbons and mild chemicals	-18F -28C	50 to 140F 10 to 60C	176F 80C	1.23	2.64
EPDM	Caustic solutions and dilute acids. Poor on oils and solvents	-11F -24C	50 to 140F 10 to 60C	212F 100C	1.23	2.64
Geolast	General purpose for use on water, most hydrocarbons and mild chemicals	-10F -23C	50 to 140F 10 to 60C	212F 100C	1.0	N/A
Neoprene	Excellent abrasion resistance. Widely used in the ceramics industry on dirty wate, clays, grout etc.	-4F -20C	50 to 130F 10 to 54C	212F 100C	1.23	2.64
Polyester	High mechanical strength. Suitable with most oils, solvents and hydrocarbons	-40F -40C	50 to 130F 10 to 54C	158F 70C	N/A	N/A
Polyurethane	Excellent abrasion resistance, dirty water, oils and hydrocarbons	-40F -40C	50 to 130F 10 to 54C	158F 70C	N/A	N/A
PTFE	Aggressive chemicals and solvents but with low abrasion resistance	32F 0C	50 to 212F 10 to 100C	356F 180C	N/A	N/A
Santoprene	Caustic solutions and dilute acids. Excellent abrasion resistance	-10F -23C	50 to 140F 10 to 60C	212F 100C	0.98	N/A
Stainless Steel	N/A	N/A	N/A	N/A	7.80	N/A
Viton	Aggressive chemicals and most solvents. High temperature uses	0F -18C	75 to 212F 24 to 100C	356F 180C	1.80	3.2

## Pump Identification

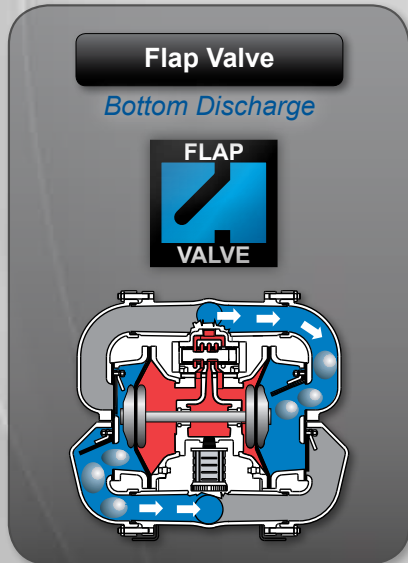
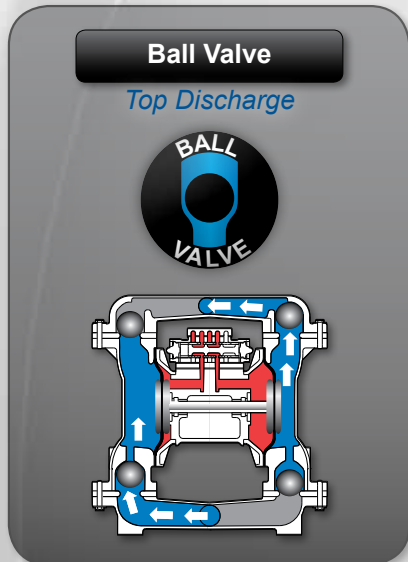

## Viscosity Guide

This table is a guide only – cps = centipoise

X75 - 3" Pumps		Maximum 25000						
B50 - 2" Pumps		Maximum 12000						
B40 - 1 1/2" Pumps		Maximum 12000						
B25 - 1" Pumps		Maximum 5000						
B15 - 1/2" Pumps		Maximum 5000						
B10 - 3/8" Pumps		Maximum 2000						
B06 - 1/4" Pumps		Maximum 2000						
1	200	500	1000	2000	4000	10000	15000	
Water 1 cps	Tomato Juice 176 cps	SAE 30 Oil 352 cps	Glycerine 880 cps	SAE 50 Oil 1561 cps	Glue 3000 cps	Mayonnaise 5000 cps	Molasses B 8640 cps	Scour Cream 15200 cps
								SAE 70 Oil 17640 cps

## Recommended Installation Guidelines

For best results, the factory recommends installing the surge suppressor on the discharge side of the pump. Though the more common top-ported pump is shown here, this recommendation also applies to bottom, side and dual-ported diaphragm pumps.

The compressed air supply line to the surge suppressor should connect before a filter/regulator unit limited to inlet air of 125 PSI. To reduce piping and pump connection stresses, we recommend flexible connections on both inlet and outlet piping and air inlet connections.

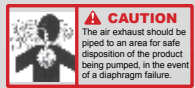
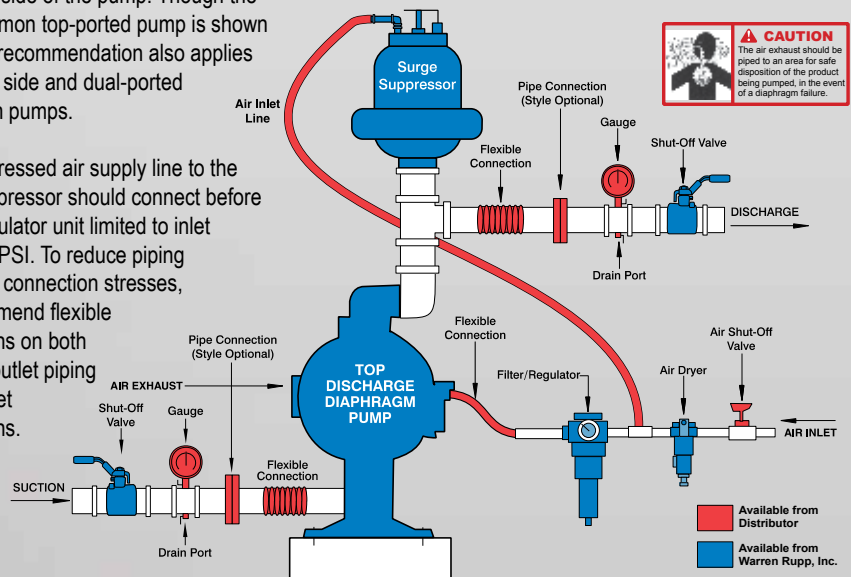



- Simple construction, easy to maintain
- Self priming, ideal for emptying containers
- Pressures to 5 bar (73 PSI)
- Flow rates up to 16 litres/minute (4.3 gal/min)
- Bolted construction for safety
- Low break out pressure requirement
- Reliable pneumatic air valve system



### TYPICAL CODE = B06. 04. PP. BB. TTP

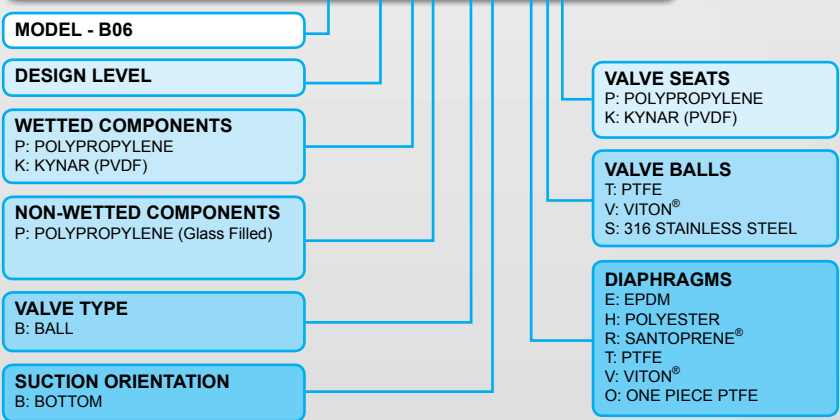

**Example above:** B06.04.PP.BB.TTP refers to B06 model, Design Level 4 with Polypropylene wetted components, Glass filled Polypropylene non-wetted components, with PTFE Diaphragms and Valve Balls and Polypropylene Seats.

### Performance Curve

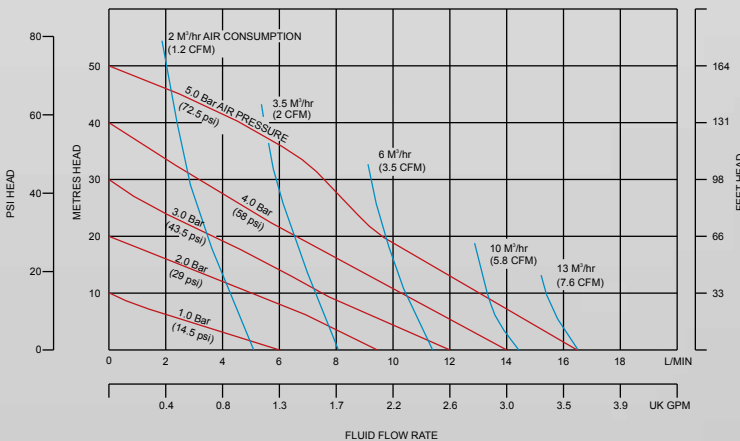

**Note:** The above Performance Curve has been determined under the following conditions: flooded suction, pumping clean water through a calibrated electronic flow meter with pulsation dampener and silencer fitted.

### Technical Data

#### NON-METALLIC SERIES B06 POLYPROPYLENE & PVDF

Maximum Delivery:	16 ltrs/min (4.3 gal/min)
Max. Working Pressure:	5 bar (73 PSI)
Max. Solid Particle Size:	1 mm. (0.04")
Air Inlet:	1/4" NPT
Temperature Limits:	Determined by Elastomers
Suction Lift (Dry):	1.5 m. (4.9')
Suction Lift (Wet):	4.1 m. (13.5')
Fluid Inlet/Outlet:	1/4" BSP / NPT
Installation:	Wall or surface mounted
Accessories Included:	Exhaust air Silencer

#### Shipping Weights:

Polypropylene	1.7 kg. (3.8 lbs.)
PVDF	1.9 kg. (4.2 lbs.)

**Shipping Dimensions:** 240 x 180 x 200 mm.  
(9.5" x 7.1" x 7.9")

### Dimensions

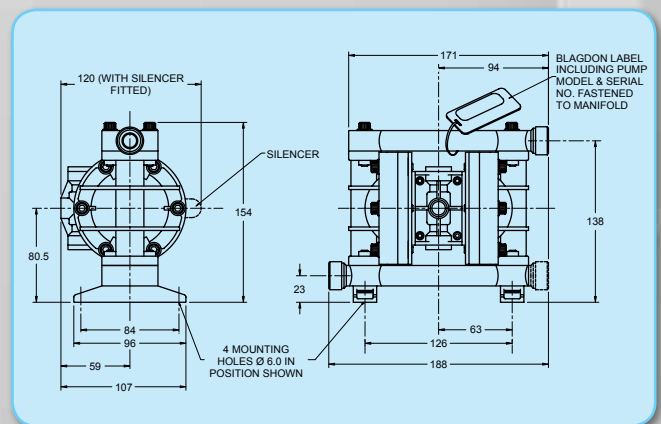

- Simple construction, easy to maintain
- Self priming, ideal for emptying containers
- High quality investment cast design
- Pressures to 8.6 bar (125 PSI)
- Flow rates up to 18 litres/minute (4.8 gal/min)
- Bolted construction for safety
- Reliable pneumatic air valve system
- Constructed from 316L Stainless Steel



### TYPICAL CODE = B06. 04. SS. BB. TTS

**MODEL - B06: Standard**  
X06: ATEX Approved

**DESIGN LEVEL**

**WETTED COMPONENTS**  
S: 316L STAINLESS STEEL

**NON-WETTED COMPONENTS**  
S: 316L STAINLESS STEEL

**VALVE TYPE**  
B: BALL

**SUCTION ORIENTATION**  
B: BOTTOM

**VALVE SEATS**  
S: 316L STAINLESS STEEL

**VALVE BALLS**  
T: PTFE  
V: VITON®  
S: 316 STAINLESS STEEL

**DIAPHRAGMS**  
E: EPDM  
H: POLYESTER  
R: SANTOPRENE®  
T: PTFE  
V: VITON®  
O: ONE PIECE PTFE

### Technical Data

#### METALLIC SERIES B06 STAINLESS STEEL

Maximum Delivery:	18 ltrs/min (4.8 gal/min)
Max. Working Pressure:	8.6 bar (125 PSI)
Max. Solid Particle Size:	1 mm. (0.04")
Air Inlet:	1/4" NPT
Temperature Limits:	Determined by Elastomers
Suction Lift (Dry):	1.5 m. (4.9')
Suction Lift (Wet):	4.1 m. (13.5')
Fluid Inlet/Outlet:	1/4" BSP / NPT
Installation:	Wall or surface mounted
Accessories Included:	Exhaust air Silencer

#### Shipping Weight:

Stainless Steel 3.7 kg. (8.2 lbs.)

**Shipping Dimensions:** 240 x 180 x 200 mm.  
(9.5" x 7.1" x 7.9")

### Performance Curve

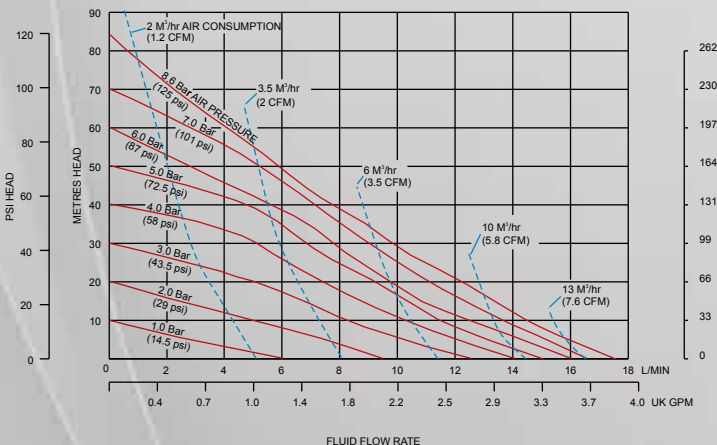

### Dimensions

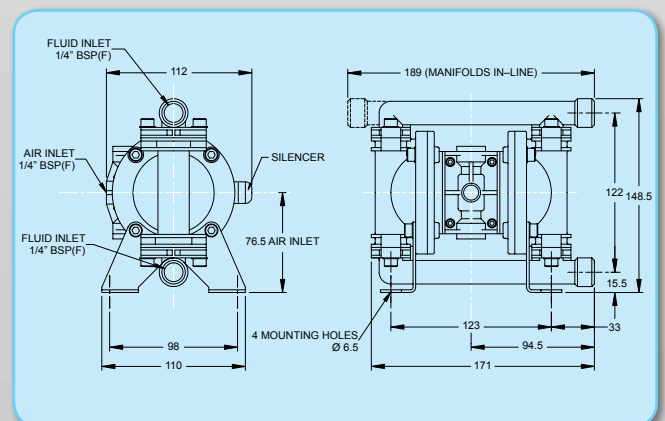

**Note:** The above Performance Curve has been determined under the following conditions: flooded suction, pumping clean water through a calibrated electronic flow meter with pulsation dampener and silencer fitted.

- Simple construction, easy to maintain
- Self priming, ideal for emptying containers
- Strong, robust design
- Pressures to 8 bar (116 PSI)
- Flow rates up to 48 litres/minute (13 gal/min)
- Flanged or screwed end connections
- Pneumatic air valve, reliable and easy



## TYPICAL CODE = B15. 01. PT. BB. TTP -LF

**MODEL - B15: Standard**  
X15: ATEX Approved

**DESIGN LEVEL**

**WETTED COMPONENTS**  
P: POLYPROPYLENE  
K: KYNAR (PVDF)  
G: CONDUCTIVE POLYPROPYLENE

**NON-WETTED COMPONENTS**  
T: EPOXY COATED ALUMINUM  
W: EPOXY COATED STAINLESS STEEL

**VALVE TYPE**  
B: BALL

**SUCTION ORIENTATION**  
B: BOTTOM

**LUBE FREE**

**VALVE SEATS**  
B: BUNA-N K: KYNAR (PVDF)  
E: EPDM V: VITON  
N: NEOPRENE  
P: POLYPROPYLENE

**VALVE BALLS**  
B: BUNA-N K: KYNAR (PVDF)  
E: EPDM V: VITON  
N: NEOPRENE  
S: 316 STAINLESS STEEL

**DIAPHRAGMS**  
B: BUNA-N  
P: POLYPROPYLENE  
E: EPDM R: SANTROPENE  
H: POLYESTER T: PTFE  
N: NEOPRENE V: VITON  
O: ONE PIECE PTFE

## Technical Data

### MOULDED NON-METALLIC SERIES B15 POLYPROPYLENE & PVDF

Maximum Delivery:	48 ltrs/min (13 gal/min)
Max. Working Pressure:	8 bar (116 PSI)
Max. Solid Particle Size:	2 mm. (0.08")
Air Inlet:	1/4" NPT
Temperature Limits:	Determined by Elastomers
Suction Lift (Dry):	4.6 m. (15.1')
Suction Lift (Wet):	6.1 m. (20')
Fluid Inlet/Outlet:	1/2 ANSI #150 RF Flanged
Installation:	Wall or surface mounted
Accessories Included:	Exhaust air Silencer

### Shipping Weights:

Polypropylene/Aluminum	5.3 kg. (11.7 lbs.)
PVDF/Aluminum	7 kg. (15.4 lbs.)
Polypropylene/Stainless Steel	12 kg. (26.5 lbs.)
PVDF/Stainless Steel	13.5 kg. (29.8 lbs.)

**Shipping Dimensions:** 320 x 200 x 340 mm.  
(12.6" x 7.9" x 13.4")

\*X Series ATEX pumps are ONLY applicable to Conductive Polypropylene pumps.

## Performance Curve

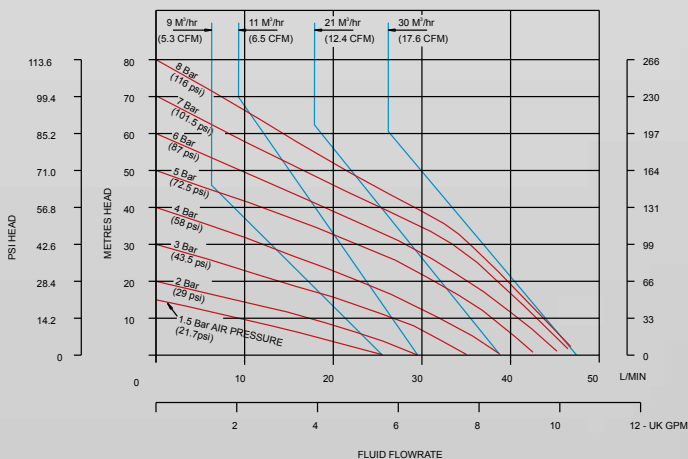

**Note:** The above Performance Curve has been determined under the following conditions: flooded suction, pumping clean water through a calibrated electronic flow meter with pulsation dampener and silencer fitted.

## Dimensions

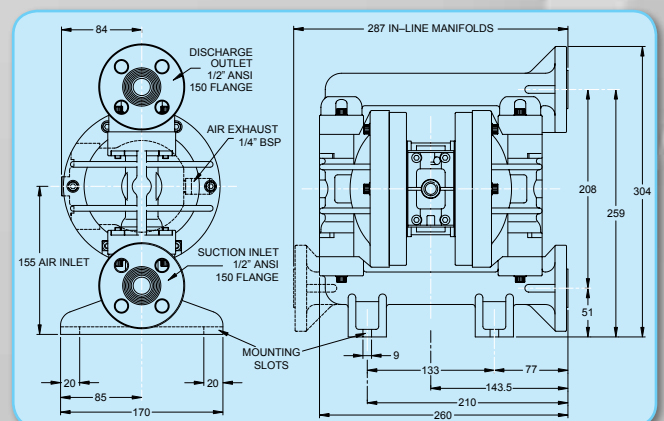

- Simple construction, easy to maintain
- Self priming, ideal for emptying containers
- Pressures to 8.6 bar (125 PSI)
- Flow rates up to 60 litres/minute (16 gal/min)
- Bolted construction for greater integrity
- Reliable pneumatic air valve design
- Portable



### TYPICAL CODE = B15. 01. AA. BB. TTS -LF

**MODEL - B15: Standard**  
X15: ATEX Approved

**DESIGN LEVEL**

**WETTED COMPONENTS**  
A: ALUMINUM

**NON-WETTED COMPONENTS**  
A: ALUMINUM

**VALVE TYPE**  
B: BALL

**SUCTION ORIENTATION**  
B: BOTTOM

#### LUBE FREE

#### VALVE SEATS

A: ALUMINUM  
B: BUNA-N  
E: EPDM  
N: NEOPRENE  
V: VITON  
S: 316 STAINLESS STEEL

#### VALVE BALLS

B: BUNA-N V: VITON  
E: EPDM T: PTFE  
N: NEOPRENE  
S: 316 STAINLESS STEEL

#### DIAPHRAGMS

B: BUNA-N  
P: POLYPROPYLENE  
E: EPDM  
R: SANTROPENE  
H: POLYESTER T: PTFE  
N: NEOPRENE V: VITON  
O: ONE PIECE PTFE

### Technical Data

#### METALLIC SERIES B15 ALUMINUM

Maximum Delivery: 60 ltrs/min (16 gal/min)  
Max. Working Pressure: 8.6 bar (125 PSI)  
Max. Solid Particle Size: 2 mm. (0.08")  
Air Inlet: 1/4" NPT  
Temperature Limits: Determined by Elastomers  
Suction Lift (Dry): 4.6 m. (15.1')  
Suction Lift (Wet): 6.1 m. (20')  
Fluid Inlet/Outlet: 1/2 BSP / NPT  
Installation: Wall or surface mounted  
Accessories Included: Exhaust air Silencer

#### Shipping Weight:

Aluminum 5.9 kg. (13 lbs.)

**Shipping Dimensions:** 320 x 200 x 340 mm.  
(12.6" x 7.9" x 13.4")

### Performance Curve

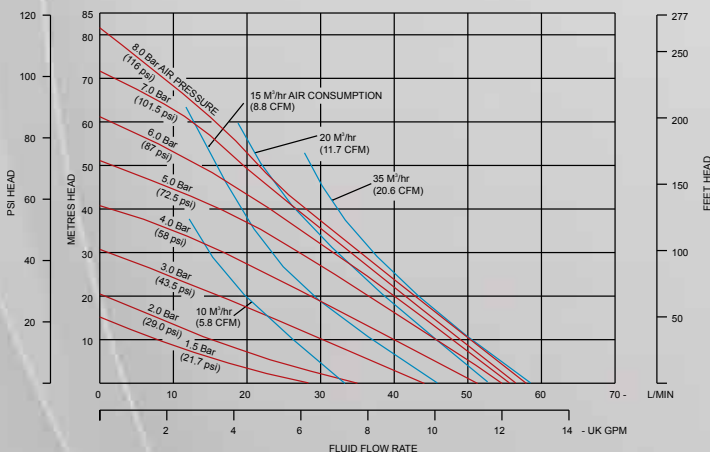

### Dimensions

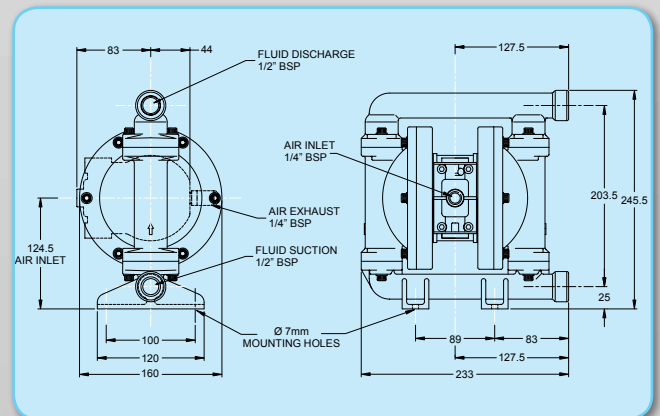

**Note:** The above Performance Curve has been determined under the following conditions: flooded suction, pumping clean water through a calibrated electronic flow meter with pulsation dampener and silencer fitted.

- Simple construction, easy to maintain
- Self priming, ideal for emptying containers
- Pressures to 8.6 bar (125 PSI)
- Flow rates up to 60 litres/minute (16 gal/min)
- Bolted construction for greater integrity
- 316L Stainless Steel



### TYPICAL CODE = B15. 01. SA. BB. TTS -LF

<b>MODEL - B15: Standard</b> X15: ATEX Approved	<b>LUBE FREE</b>
<b>DESIGN LEVEL</b>	<b>VALVE SEATS</b> S: 316 STAINLESS STEEL
<b>WETTED COMPONENTS</b> S: 316 STAINLESS STEEL	<b>VALVE BALLS</b> B: BUNA-N      T: PTFE E: EPDM        V: VITON N: NEOPRENE S: 316 STAINLESS STEEL
<b>NON-WETTED COMPONENTS</b> A: ALUMINUM S: 316 STAINLESS STEEL	<b>DIAPHRAGMS</b> B: BUNA-N P: POLYPROPYLENE E: EPDM R: SANTROPENE H: POLYESTER    T: PTFE N: NEOPRENE    V: VITON O: ONE PIECE PTFE
<b>VALVE TYPE</b> B: BALL	
<b>SUCTION ORIENTATION</b> B: BOTTOM	

### Technical Data

#### METALLIC SERIES B15 STAINLESS STEEL

Maximum Delivery:	60 ltrs/min (16 gal/min)
Max. Working Pressure:	8.6 bar (125 PSI)
Max. Solid Particle Size:	2 mm. (0.08")
Air Inlet:	1/4" NPT
Temperature Limits:	Determined by Elastomers
Suction Lift (Dry):	4.6 m. (15.1')
Suction Lift (Wet):	6.1 m. (20')
Fluid Inlet/Outlet:	1/2 BSP / NPT
Installation:	Wall or surface mounted
Accessories Included:	Exhaust air Silencer

#### Shipping Weights:

Stainless Steel/Aluminum	9.7 kg. (12.4 lbs.)
Stainless Steel	15 kg. (33.1 lbs.)

**Shipping Dimensions:** 320 x 200 x 340 mm.  
(12.6" x 7.9" x 13.4")

### Performance Curve

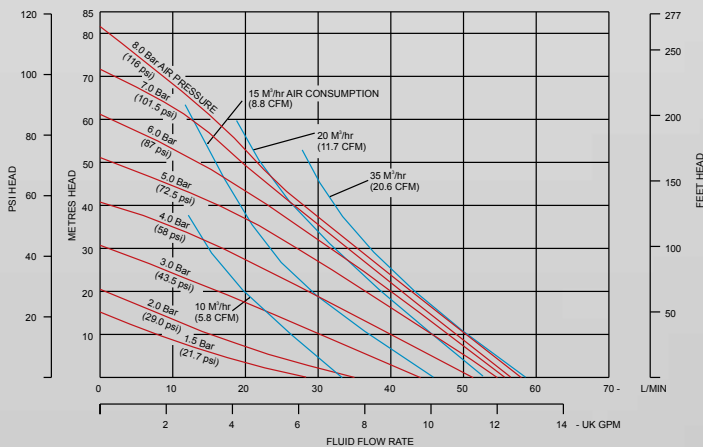

**Note:** The above Performance Curve has been determined under the following conditions: flooded suction, pumping clean water through a calibrated electronic flow meter with pulsation dampener and silencer fitted.

### Dimensions

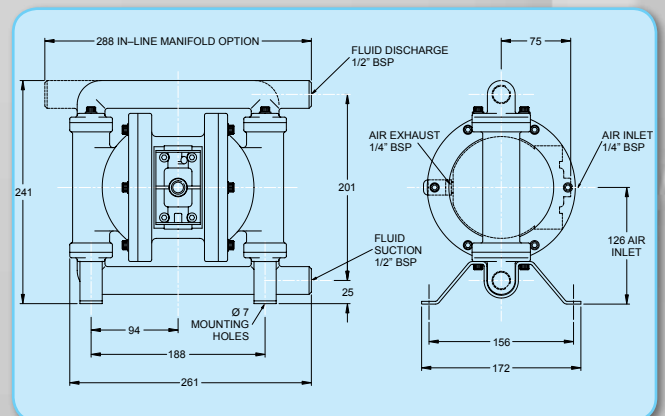

- Simple construction, easy to maintain
- Available in virgin and conductive PTFE
- Chemically inert
- Flanged end connections
- ATEX approved - intrinsically safe
- Reliable, proven pneumatic air valve
- Strong, robust design



### TYPICAL CODE = B15. 00. TS. BB. TTT -LF

**MODEL - B15: Standard**  
X15: ATEX Approved

**DESIGN LEVEL**

**WETTED COMPONENTS**  
T: PTFE  
4: CONDUCTIVE PTFE

**NON-WETTED COMPONENTS**  
4: CONDUCTIVE PTFE  
5: POLYTHYLENE (HDPE)  
S: 316 STAINLESS STEEL

**VALVE TYPE**  
B: BALL  
W: WEIGHTED

**SUCTION ORIENTATION**  
B: BOTTOM

**LUBE FREE**

**VALVE SEATS**  
T: PTFE

**VALVE BALLS**  
T: PTFE

**DIAPHRAGMS**  
T: PTFE  
X: PTFE/MITON (HIGH TEMP.)

\*X Series ATEX pumps are ONLY applicable to Conductive PTFE pumps.

### Technical Data

#### NON-METALLIC SERIES B15 CONDUCTIVE / VIRGIN PTFE

Maximum Delivery:	48 ltrs/min (13 gal/min)
Max. Working Pressure:	7 bar (102 PSI)
Max. Solid Particle Size:	2 mm. (0.08")
Air Inlet:	1/4" NPT
Temperature Limits:	Determined by Elastomers
Suction Lift (Dry):	4.6 m. (15.1')
Suction Lift (Wet):	6.1 m. (20')
Fluid Inlet/Outlet:	1/2 BSP / NPT
Installation:	Wall or surface mounted
Accessories Included:	Exhaust air Silencer

#### Shipping Weights:

Conductive PTFE	16 kg. (35.3 lbs.)
Virgin PTFE	16 kg. (35.3 lbs.)

**Shipping Dimensions:** 320 x 200 x 340 mm.  
(12.6" x 7.9" x 13.4")

### Performance Curve

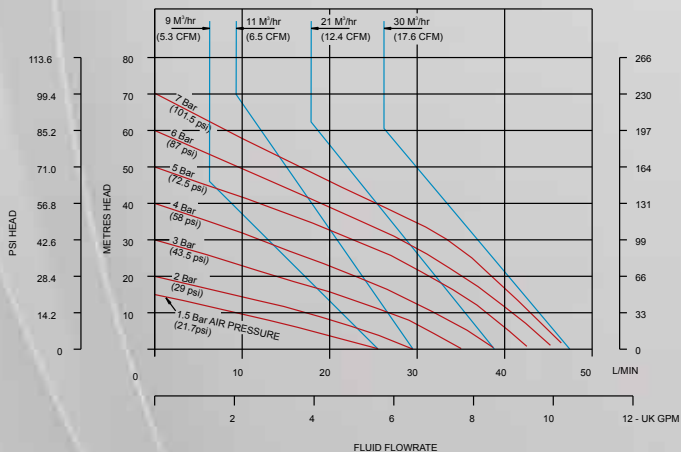

**Note:** The above Performance Curve has been determined under the following conditions: flooded suction, pumping clean water through a calibrated electronic flow meter with pulsation dampener and silencer fitted.

### Dimensions

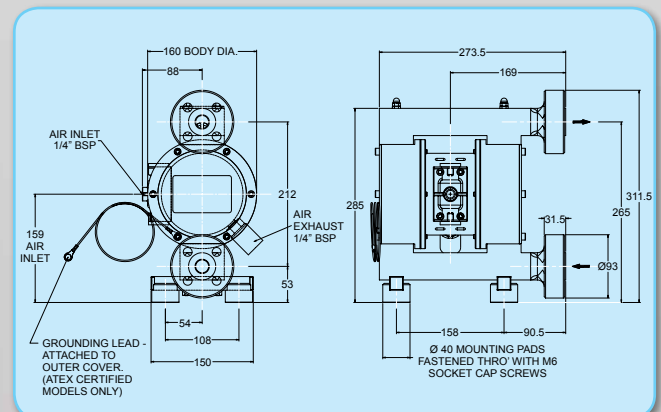

- Range of DIN/RJT and Ferrule connections
- Self priming, ideal for emptying containers
- Food grade elastomers-EPDM/PTFE
- Pressures to 8.6 bar (125 PSI)
- Capable of handling high viscosity & S.G.
- Certified CIP cleanable
- EU Design approval
- 316L stainless steel



## TYPICAL CODE = B15. 01. SA. BB. TTS -LF

**MODEL - B15: Standard**  
X15: ATEX Approved

**DESIGN LEVEL**

**WETTED COMPONENTS**  
Z: 316 STAINLESS STEEL (POLISHED)

**NON-WETTED COMPONENTS**  
S: 316 STAINLESS STEEL  
F: NICKEL PLATED ALUMINUM

**VALVE TYPE**  
B: BALL

**SUCTION ORIENTATION**  
B: BOTTOM

**LUBE FREE**

**VALVE SEATS**  
E: FOOD GRADE EPDM

**VALVE BALLS**  
E: FOOD GRADE EPDM  
T: PTFE  
S: 316 STAINLESS STEEL

**DIAPHRAGMS**  
E: FOOD GRADE EPDM  
T: PTFE  
O: ONE PIECE PTFE

## Technical Data

### HYGIENIC SERIES B15 STAINLESS STEEL

Maximum Delivery:	75 ltrs/min (20 gal/min)
Max. Working Pressure:	8.6 bar (125 PSI)
Max. Solid Particle Size:	2 mm. (0.08")
Air Inlet:	1/4" NPT
Temperature Limits:	Determined by Elastomers
Suction Lift (Dry):	4.6 m. (15.1')
Suction Lift (Wet):	6.1 m. (20')
Fluid Inlet/Outlet:	1" RJT (Standard)
Installation:	Wall or surface mounted
Accessories Included:	Exhaust air Silencer

### Shipping Weights:

Stainless Steel/Aluminum	10.5 kg. (23.1 lbs.)
Stainless Steel	15.8 kg. (34.8 lbs.)

**Shipping Dimensions:** 320 x 210 x 390 mm.  
(12.6" x 8.3" x 15.4")

## Performance Curve

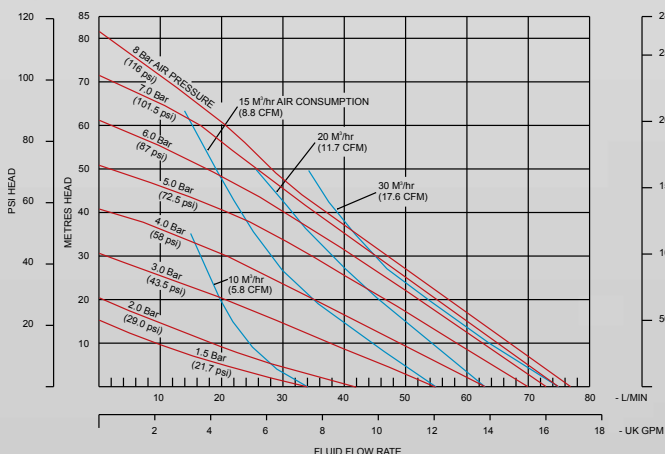

**Note:** The above Performance Curve has been determined under the following conditions: flooded suction, pumping clean water through a calibrated electronic flow meter with pulsation dampener and silencer fitted.

## Dimensions

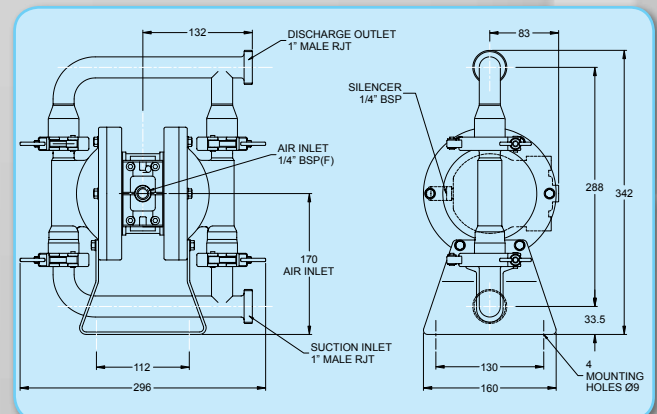

- Material options suitable for a wide range of chemicals
- Simple construction, easy to maintain
- Self priming, ideal for emptying containers
- Pressures to 8 bar (116 PSI)
- Flow rates up to 152 litres/minute (40 gal/min)
- Flanged or screwed end connections
- Reliable, pneumatic air valve
- Strong, robust design, bolted construction

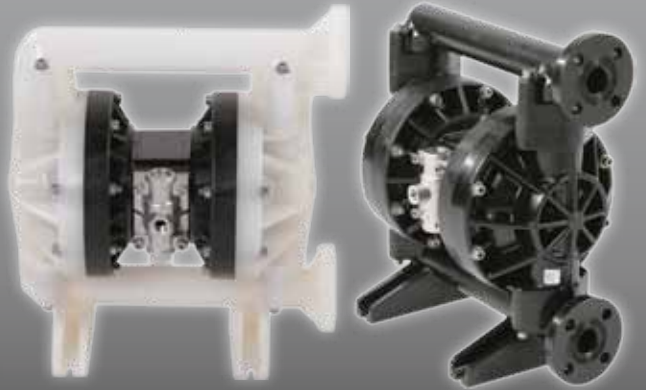

**TYPICAL CODE = B25. 05. PT. BB. EEP -LF**

**MODEL - B25: Standard**  
X25: ATEX Approved

**DESIGN LEVEL**

**WETTED COMPONENTS**  
P: POLYPROPYLENE  
K: KYNAR (PVDF)  
G: CONDUCTIVE POLYPROPYLENE

**NON-WETTED COMPONENTS**  
T: ALUMINUM / EPOXY PAINTED  
W: STAINLESS STEEL / EPOXY PAINTED

**VALVE TYPE**  
B: BALL  
W: WEIGHTED

**SUCTION ORIENTATION**  
B: BOTTOM

**LUBE FREE**

**VALVE SEATS**  
B: BUNA-N N: NEOPRENE  
E: EPDM  
K: KYNAR (PVDF)  
P: POLYPROPYLENE

**VALVE BALLS**  
B: BUNA-N T: PTFE  
E: EPDM V: VITON  
N: NEOPRENE  
S: STAINLESS STEEL

**DIAPHRAGMS**  
B: BUNA-N T: PTFE  
E: EPDM V: VITON  
H: POLYESTER (HYTREL)  
N: NEOPRENE  
P: POLYPROPYLENE  
R: SANTOPRENE  
O: ONE PIECE PTFE

\*X Series ATEX pumps are ONLY applicable to Conductive Polypropylene pumps.

### Technical Data

#### MOULDED NON-METALLIC SERIES B25 POLYPROPYLENE & PVDF

Maximum Delivery:	152 ltrs/min (40 gal/min)
Max. Working Pressure:	8 bar (116 PSI)
Max. Solid Particle Size:	3 mm. (0.12")
Air Inlet:	3/8" NPT
Temperature Limits:	Determined by Elastomers
Suction Lift (Dry):	6.1 m. (20')
Suction Lift (Wet):	7.6 m. (24.9')
Fluid Inlet/Outlet:	1" ANSI #150 Flanged RF
Installation:	Wall or surface mounted
Accessories Included:	Exhaust air Silencer

#### Shipping Weights:

Polypropylene/Aluminum	13.5 kg. (29.8 lbs.)
PVDF/Aluminum	18 kg. (39.7 lbs.)
Polypropylene/Stainless Steel	18 kg. (39.7 lbs.)
PVDF/Stainless Steel	20 kg. (44.1 lbs.)

**Shipping Dimensions:** 440 x 260 x 470 mm.  
(17.3" x 10.2" x 18.5")

### Performance Curve

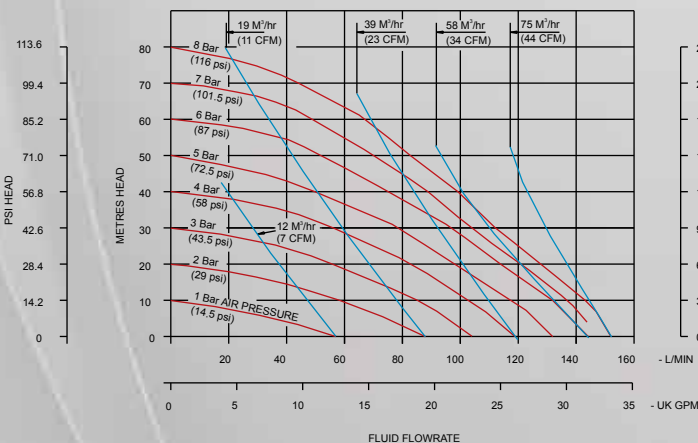

**Note:** The above Performance Curve has been determined under the following conditions: flooded suction, pumping clean water through a calibrated electronic flow meter with pulsation dampener and silencer fitted.

### Dimensions

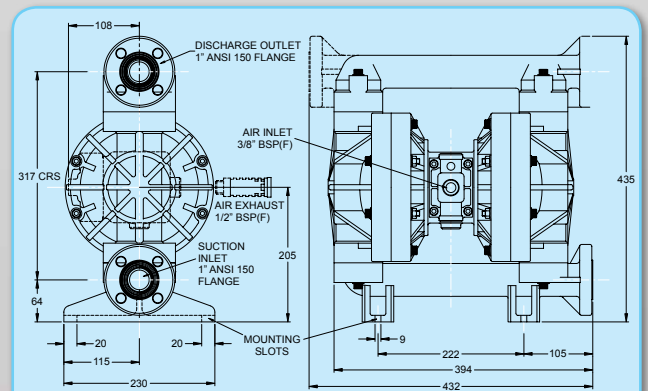



- Material options suitable for a wide range of applications
- Simple construction, easy to maintain
- Self priming, ideal for emptying containers
- Pressures to 8.6 bar (125 PSI)
- Flow rates up to 180 litres/minute (48 gal/min)
- Bolted construction for greater integrity
- Weighted Valve Balls for high S.G. and viscous fluids
- Reliable, pneumatic air valve



## TYPICAL CODE = B25. 05. AA. BB. BBS -LF

**MODEL - B2505: Standard**  
X2505: ATEX Approved

**DESIGN LEVEL**

**WETTED COMPONENTS**

A: ALUMINUM  
S: 316L STAINLESS STEEL  
C: CAST IRON

**NON-WETTED COMPONENTS**

A: ALUMINUM  
S: 316L STAINLESS STEEL

**VALVE TYPE**

B: BALL  
W: WEIGHTED

**SUCTION ORIENTATION**

B: BOTTOM

**LUBE FREE**

**VALVE SEATS**

S: 316 STAINLESS STEEL

**VALVE BALLS**

B: BUNA-N      T: PTFE  
E: EPDM      V: VITON  
N: NEOPRENE   D: DELRIN  
S: 316 STAINLESS STEEL

**DIAPHRAGMS**

B: BUNA-N  
P: POLYURETHANE  
E: EPDM  
R: SANTROPENE  
H: POLYESTER   T: PTFE  
N: NEOPRENE   V: VITON  
O: ONE PIECE PTFE

## Technical Data

### METALLIC SERIES B25 ALUMINUM, STAINLESS STEEL, CAST IRON

Maximum Delivery:	180 ltrs/min (48 gal/min)
Max. Working Pressure:	8.6 bar (125 PSI)
Max. Solid Particle Size:	3 mm. (0.12")
Air Inlet:	3/8" NPT
Temperature Limits:	Determined by Elastomers
Suction Lift (Dry):	6.1 m. (20')
Suction Lift (Wet):	7.6 m. (24.9')
Fluid Inlet/Outlet:	1" BSP / NPT
Installation:	Wall or surface mounted
Accessories Included:	Exhaust air Silencer

### Shipping Weights:

Aluminum	16 kg. (35.3 lbs.)
Cast Iron/Aluminum	25 kg. (55.1 lbs.)
Stainless Steel/Aluminum	25 kg. (55.1 lbs.)

**Shipping Dimensions:** 400 x 300 x 470 mm.  
(15.8" x 11.8" x 18.5")

## Performance Curve

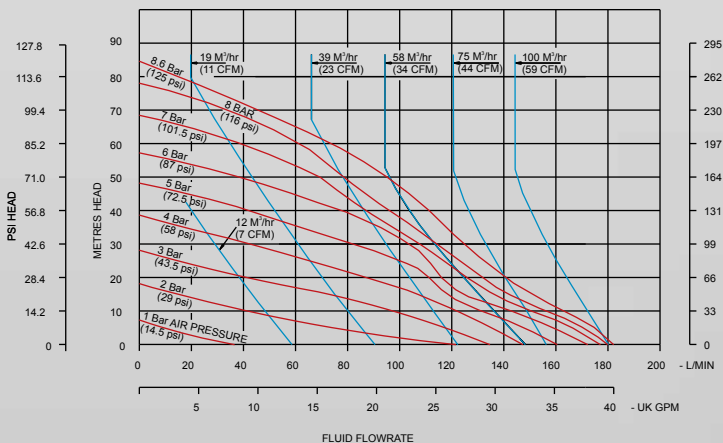

**Note:** The above Performance Curve has been determined under the following conditions: flooded suction, pumping clean water through a calibrated electronic flow meter with pulsation dampener and silencer fitted.

## Dimensions

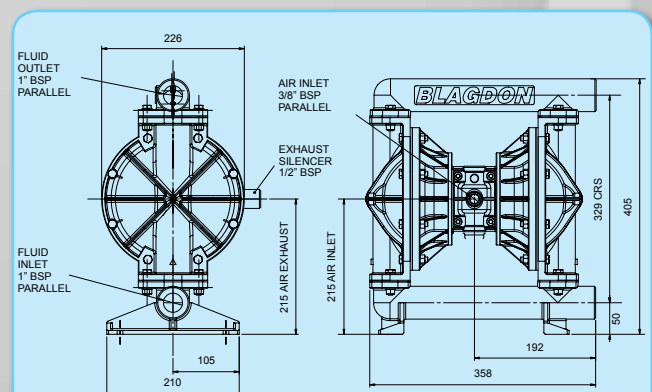

- Simple construction, easy to maintain
- Available in virgin and conductive PTFE
- Chemically inert
- Flanged end connections
- ATEX approved - intrinsically safe
- Reliable, proven pneumatic air valve
- Strong, robust design

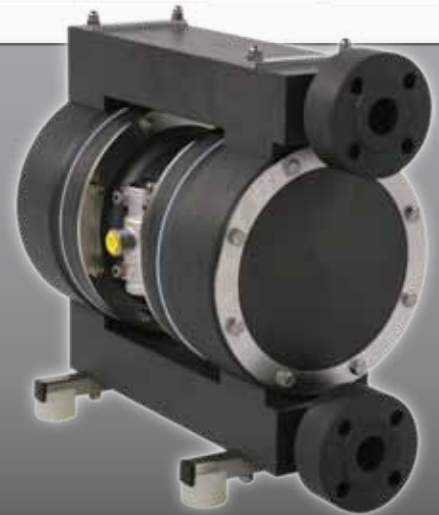

**TYPICAL CODE = B25. 05. T5. BB. TTT -LF**

<b>MODEL - B25: Series 00</b> <b>X25: ATEX Approved</b>	<b>LUBE FREE</b>
<b>DESIGN LEVEL</b>	<b>VALVE SEATS</b> T: PTFE
<b>WETTED COMPONENTS</b> T: PTFE 4: CONDUCTIVE PTFE	<b>VALVE BALLS</b> T: PTFE
<b>NON-WETTED COMPONENTS</b> 4: CONDUCTIVE PTFE 5: POLYTHYLENE (HDPE)	<b>DIAPHRAGMS</b> T: PTFE X: PTFE/VITON (HIGH TEMP.)
<b>VALVE TYPE</b> B: BALL W: WEIGHTED	
<b>SUCTION ORIENTATION</b> B: BOTTOM	

\*X Series ATEX pumps are ONLY applicable to Conductive PTFE pumps.

### Technical Data

#### NON-METALLIC SERIES B25 CONDUCTIVE / VIRGIN PTFE

Maximum Delivery:	136 ltrs/min (36 gal/min)
Max. Working Pressure:	7 bar (102 PSI)
Max. Solid Particle Size:	3 mm. (0.12")
Air Inlet:	3/8" NPT
Temperature Limits:	Determined by Elastomers
Suction Lift (Dry):	6.1 m. (20')
Suction Lift (Wet):	7.6 m. (24.9')
Fluid Inlet/Outlet:	1" BSP / ANSI #150 Flange
Installation:	Wall or surface mounted
Accessories Included:	Exhaust air Silencer

#### Shipping Weights:

Conductive PTFE	40 kg. (88.2 lbs.)
Virgin PTFE	37 kg. (81.6 lbs.)

**Shipping Dimensions:** 500 x 300 x 450 mm. (19.7" x 11.8" x 17.7")

### Performance Curve

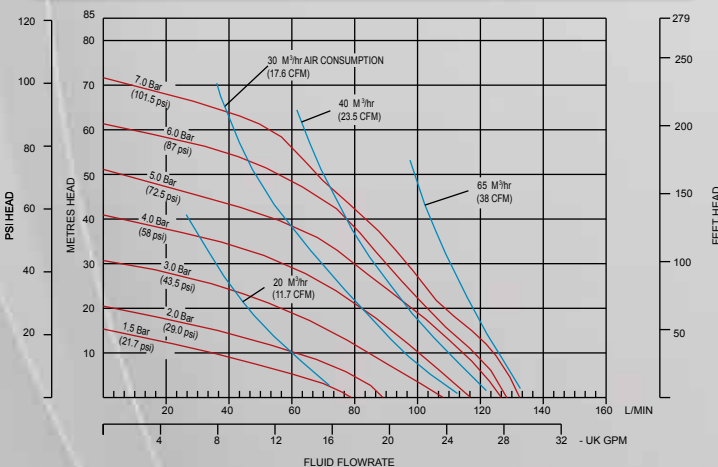

**Note:** The above Performance Curve has been determined under the following conditions: flooded suction, pumping clean water through a calibrated electronic flow meter with pulsation dampener and silencer fitted.

### Dimensions

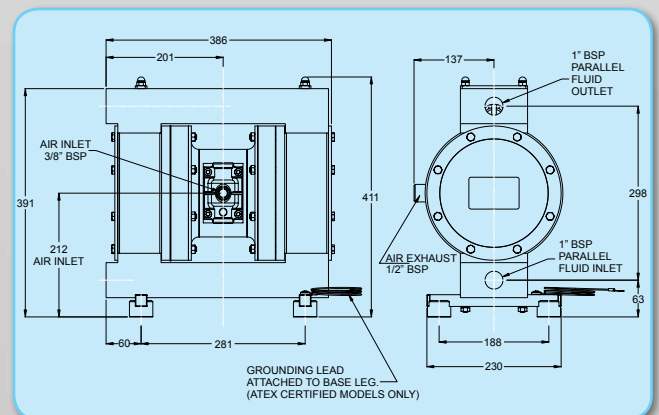

- Robust construction, easy to maintain
- Can easily handle viscous, high S.G. and high head applications
- Smooth action, less vibration and wear
- Pressures to 16 bar (232 PSI)
- Flow rates up to 125 litres/minute (33 gal/min)
- Bolted construction for greater integrity
- Reliable pneumatic air valve
- Stalls against closed head without damage
- Re-start on demand



## TYPICAL CODE = B25. 05. AA. W3. NNS

**MODEL - B25: Series 00**  
X25: ATEX Approved

**DESIGN LEVEL**

**WETTED COMPONENTS**

A: ALUMINUM  
S: 316 STAINLESS STEEL

**NON-WETTED COMPONENTS**

A: ALUMINUM

**VALVE TYPE**

B: BALL  
W: WEIGHTED

**MODEL DESIGNATION**

**VALVE SEATS**

S: 316 STAINLESS STEEL

**VALVE BALLS**

T: PTFE  
N: NEOPRENE  
B: BUNA-N  
E: EPDM  
S: STAINLESS STEEL  
V: VITON

**DIAPHRAGMS**

T: PTFE  
N: NEOPRENE  
B: BUNA-N  
R: SANTOPRENE  
E: EPDM  
H: POLYESTER (HYTREL)  
O: ONE PIECE PTFE  
P: POLYURETHANE  
V: VITON

## Technical Data

### METALLIC SERIES FULL FLOW 2:1 B25

Maximum Delivery:	125 ltrs/min (33 gal/min)
Max. Working Pressure:	16 bar (232 PSI)
Max. Solid Particle Size:	3 mm. (0.12")
Air Inlet:	3/8" NPT
Temperature Limits:	Determined by Elastomers
Suction Lift (Dry):	6 m. (20')
Suction Lift (Wet):	7.6 m. (24.9')
Fluid Inlet/Outlet:	1" BSP / NPT
Installation:	Surface mounted
Accessories Included:	Exhaust air Silencer

### Shipping Weights:

Stainless Steel/Aluminum	33 kg. (72.8 lbs.)
Aluminum	24.5 kg. (54 lbs.)

**Shipping Dimensions:** 480 x 320 x 480 mm.  
(18.9" x 12.6" x 18.9")

## Performance Curve

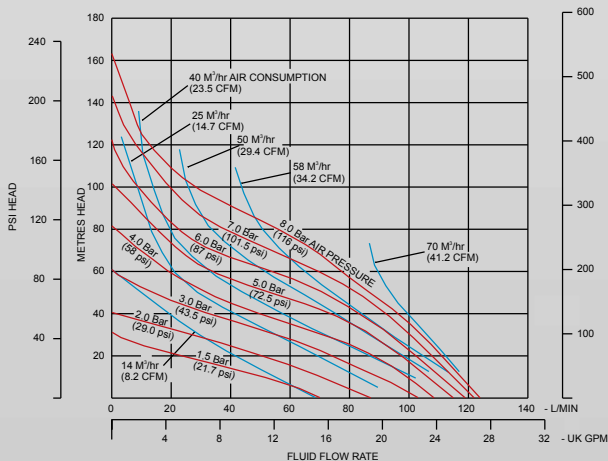

**Note:** The above Performance Curve has been determined under the following conditions: flooded suction, pumping clean water through a calibrated electronic flow meter with pulsation dampener and silencer fitted.

## Dimensions

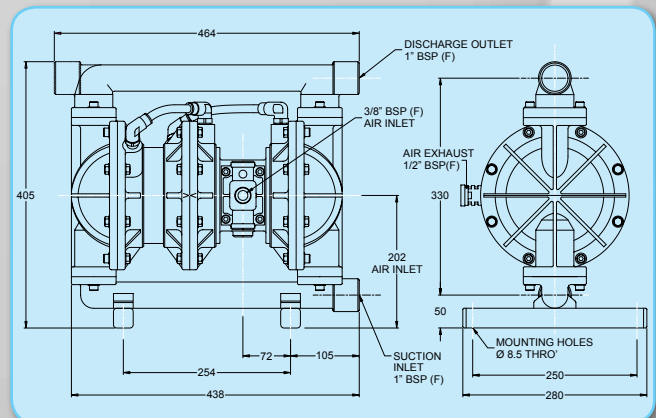

- Range of DIN/RJT and Ferrule connections
- Self priming, ideal for emptying containers
- Food grade elastomers-EPDM/PTFE
- Pressures to 8.6 bar (125 PSI)
- Capable of handling high viscosity & S.G.
- Certified CIP cleanable
- EU Design approval
- 316L Stainless Steel



### TYPICAL CODE = B25. ZF. BB. EEE -LF

**MODEL - B15: Standard**  
X15: ATEX Approved

**WETTED COMPONENTS**  
Z: 316 STAINLESS STEEL  
(ELECTRO POLISHED)

**NON-WETTED COMPONENTS**  
S: 316 STAINLESS STEEL  
F: NICKEL PLATED ALUMINUM

**VALVE TYPE**  
B: BALL

**SUCTION ORIENTATION**  
B: BOTTOM

**LUBE FREE**

**VALVE SEATS**  
E: FOOD GRADE EPDM  
S: 316 STAINLESS STEEL

**VALVE BALLS**  
E: FOOD GRADE EPDM  
T: PTFE  
S: 316 STAINLESS STEEL

**DIAPHRAGMS**  
E: FOOD GRADE EPDM  
T: PTFE

### Technical Data

#### HYGIENIC SERIES B25 STAINLESS STEEL

Maximum Delivery:	136 ltrs/min (36 gal/min)
Max. Working Pressure:	8.6 bar (125 PSI)
Max. Solid Particle Size:	5 mm. (0.2")
Air Inlet:	3/8" NPT
Temperature Limits:	Determined by Elastomers
Suction Lift (Dry):	4.6 m. (15.1')
Suction Lift (Wet):	6.1 m. (20')
Fluid Inlet/Outlet:	1" RJT
Installation:	Wall or surface mounted
Accessories Included:	Exhaust air Silencer

#### Shipping Weights:

Stainless Steel 21.5 kg. (47.4 lbs.)

**Shipping Dimensions:** 450 x 280 x 500 mm.  
(17.7" x 11" x 19.7")

### Performance Curve

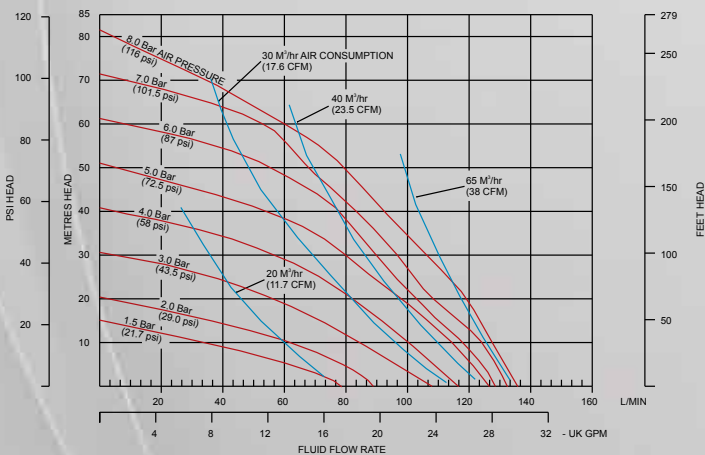

**Note:** The above Performance Curve has been determined under the following conditions: flooded suction, pumping clean water through a calibrated electronic flow meter with pulsation dampener and silencer fitted.

### Dimensions

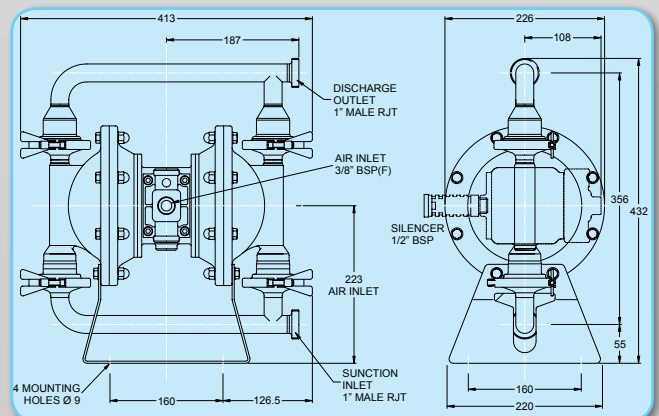

- Simple construction, easy to maintain
- Self priming, ideal for emptying containers
- Pressures to 8.6 bar (125 PSI)
- Flow rates up to 320 litres/minute (85 gal/min)
- Bolted construction for greater integrity
- Reliable, proven pneumatic air valve system



### TYPICAL CODE = B40. 05. AA. BB. BBS -LF

**MODEL - B40: Standard**  
X40: ATEX Approved

**DESIGN LEVEL**

**WETTED COMPONENTS**

A: ALUMINUM  
C: CAST IRON  
S: 316L STAINLESS STEEL

**NON-WETTED COMPONENTS**

A: ALUMINUM  
C: CAST IRON  
S: 316L STAINLESS STEEL

**VALVE TYPE**

B: BALL  
W: WEIGHTED

**SUCTION ORIENTATION**

B: BOTTOM

**LUBE FREE**

**VALVE SEATS**

B: BUNA-N      A: ALUMINUM  
E: EPDM        V: VITON  
N: NEOPRENE  
S: 316 STAINLESS STEEL

**VALVE BALLS**

B: BUNA-N      T: PTFE  
E: EPDM        V: VITON  
N: NEOPRENE  
S: 316 STAINLESS STEEL

**DIAPHRAGMS**

B: BUNA-N  
P: POLYURETHANE  
E: EPDM  
R: SANTROPENE  
H: POLYESTER    T: PTFE  
N: NEOPRENE    V: VITON  
O: ONE PIECE PTFE

### Technical Data

#### METALLIC SERIES B40 ALUMINUM, CAST IRON, STAINLESS STEEL

Maximum Delivery:	320 ltrs/min (85 gal/min)
Max. Working Pressure:	8.6 bar (125 PSI)
Max. Solid Particle Size:	6 mm. (0.24")
Air Inlet:	3/8" NPT
Temperature Limits:	Determined by Elastomers
Suction Lift (Dry):	6.1 m. (20')
Suction Lift (Wet):	7.6 m. (24.9')
Fluid Inlet/Outlet:	1 1/2" BSP / NPT
Installation:	Surface mounted
Accessories Included:	Exhaust air Silencer

#### Shipping Weights:

Aluminum	22 kg. (48.5 lbs.)
Stainless Steel/Aluminum	36 kg. (79.4 lbs.)
Stainless Steel	46 kg. (101.4 lbs.)
Stainless Steel/Cast Iron	46 kg. (101.4 lbs.)
Cast Iron/Aluminum	51.4 kg. (113.3 lbs.)
Cast Iron	61 kg. (134.5 lbs.)

**Shipping Dimensions:** 500 x 350 x 600 mm.  
(19.7" x 13.8" x 23.6")

### Performance Curve

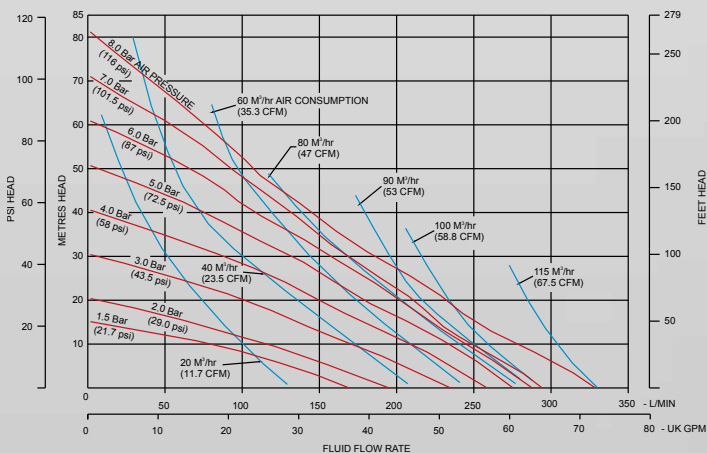

**Note:** The above Performance Curve has been determined under the following conditions: flooded suction, pumping clean water through a calibrated electronic flow meter with pulsation dampener and silencer fitted.

### Dimensions

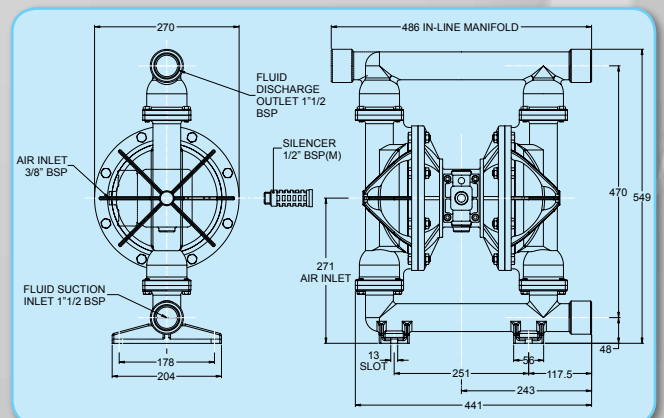

The above drawing shows Aluminum and Cast Iron only.

- Simple construction, easy to maintain
- Capable of handling high S.G. and viscous fluids
- Pressures to 8.6 bar (125 PSI)
- Flow rates up to 530 litres/minute (140 gal/min)
- Flanged end connections
- Reliable, proven pneumatic air valve

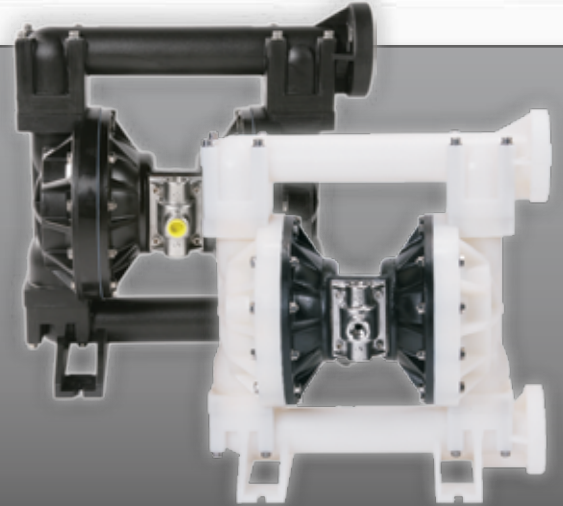

**TYPICAL CODE = B50. 05. PT. BB. EEP -LF**

**MODEL - B50: Standard**  
**X50: ATEX Approved**

**DESIGN LEVEL**

**WETTED COMPONENTS**  
P: POLYPROPYLENE  
K: KYNAR (PVDF)  
G: CONDUCTIVE POLYPROPYLENE

**NON-WETTED COMPONENTS**  
T: ALUMINUM / EPOXY PAINTED  
W: STAINLESS STEEL / EPOXY PAINTED

**VALVE TYPE**  
B: BALL  
W: WEIGHTED

**SUCTION ORIENTATION**  
B: BOTTOM

**LUBE FREE**

**VALVE SEATS**  
B: BUNA-N                   T: PTFE  
E: EPDM                    V: VITON  
N: NEOPRENE  
P: POLYPROPYLENE

**VALVE BALLS**  
B: BUNA-N                   T: PTFE  
E: EPDM                    V: VITON  
N: NEOPRENE  
S: 316 STAINLESS STEEL

**DIAPHRAGMS**  
B: BUNA-N                   T: PTFE  
E: EPDM                    V: VITON  
H: POLYESTER (HYTREL)  
N: NEOPRENE  
P: POLYPROPYLENE  
R: SANTOPRENE  
O: ONE PIECE PTFE

\*X Series ATEX pumps are ONLY applicable to Conductive Polypropylene pumps.

### Technical Data

#### MOULDED NON-METALLIC SERIES B50 POLYPROPYLENE & PVDF

Maximum Delivery:	530 ltrs/min (140 gal/min)
Max. Working Pressure:	8.6 bar (125 PSI)
Max. Solid Particle Size:	6 mm. (0.24")
Air Inlet:	3/4" NPT
Temperature Limits:	Determined by Elastomers
Suction Lift (Dry):	6.1 m. (20')
Suction Lift (Wet):	7.6 m. (24.9')
Fluid Inlet/Outlet:	2" ANSI #150 Flanged RF
Installation:	Surface mounted
Accessories Included:	Exhaust air Silencer

#### Shipping Weights:

Polypropylene/Aluminum	39.5 kg. (87.1 lbs.)
PVDF/Aluminum	50.5 kg. (111.3 lbs.)
Polypropylene/Stainless Steel	50.5 kg. (111.3 lbs.)
PVDF/Stainless Steel	70 kg. (154.3 lbs.)

**Shipping Dimensions:** 630 x 380 x 670 mm. (24.8" x 15" x 26.4")

### Performance Curve

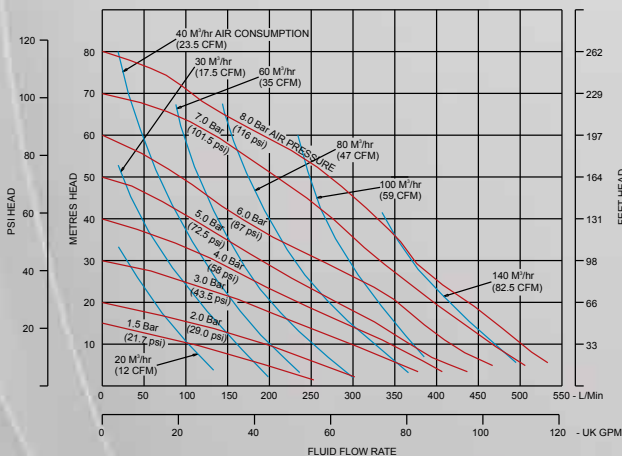

**Note:** The above Performance Curve has been determined under the following conditions: flooded suction, pumping clean water through a calibrated electronic flow meter with pulsation dampener and silencer fitted.

### Dimensions

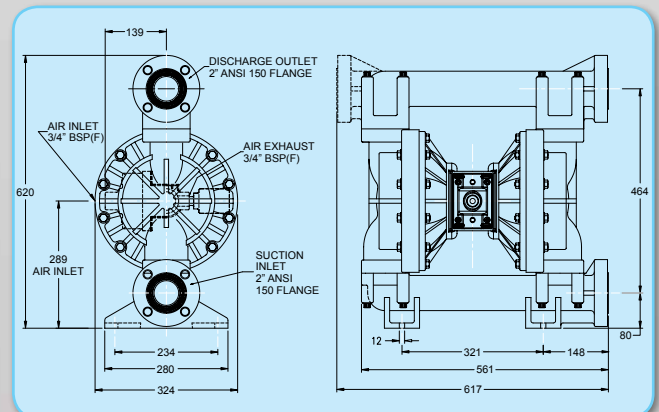

- Air valve designed for in-line maintenance
- End ported for improved flow
- Pressures to 8.6 bar (125 PSI)
- Flow rates up to 530 litres/minute (140 gal/min)
- Bolted construction for greater integrity
- Robust construction



## TYPICAL CODE = B50. 05. AA. BB. BBB -LF

**MODEL - B50: Standard**  
X50: ATEX Approved

**DESIGN LEVEL**

**WETTED COMPONENTS**

A: ALUMINUM  
C: CAST IRON

**NON-WETTED COMPONENTS**

A: ALUMINUM  
C: CAST IRON

**VALVE TYPE**

B: BALL  
W: WEIGHTED

**SUCTION ORIENTATION**

B: BOTTOM

**LUBE FREE**

**VALVE SEATS**

B: BUNA-N      A: ALUMINUM  
E: EPDM      T: PTFE  
N: NEOPRENE  
S: 316 STAINLESS STEEL

**VALVE BALLS**

B: BUNA-N      T: PTFE  
E: EPDM      V: VITON  
N: NEOPRENE  
S: 316 STAINLESS STEEL

**DIAPHRAGMS**

B: BUNA-N  
P: POLYURETHANE  
E: EPDM  
R: SANTROPENE  
H: POLYESTER      T: PTFE  
N: NEOPRENE      V: VITON  
O: ONE PIECE PTFE

## Technical Data

### METALLIC SERIES B50 ALUMINUM & CAST IRON

Maximum Delivery:	530 ltrs/min (140 gal/min)
Max. Working Pressure:	8.6 bar (125 PSI)
Max. Solid Particle Size:	6 mm. (0.24")
Air Inlet:	3/4" NPT
Temperature Limits:	Determined by Elastomers
Suction Lift (Dry):	6.1 m. (20')
Suction Lift (Wet):	7.6 m. (24.9')
Fluid Inlet/Outlet:	2" BSP / NPT
Installation:	Surface mounted
Accessories Included:	Exhaust air Silencer

### Shipping Weights:

Aluminum	38 kg. (83.8 lbs.)
Cast Iron/Aluminum	63 kg. (138.9 lbs.)
Cast Iron	90 kg. (198.4 lbs.)

**Shipping Dimensions:** 540 x 350 x 750 mm.  
(12.3" x 13.8" x 29.5")

## Performance Curve

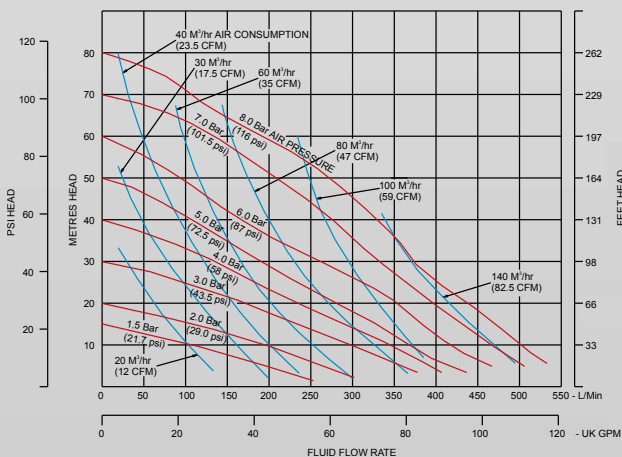

**Note:** The above Performance Curve has been determined under the following conditions: flooded suction, pumping clean water through a calibrated electronic flow meter with pulsation dampener and silencer fitted.

## Dimensions

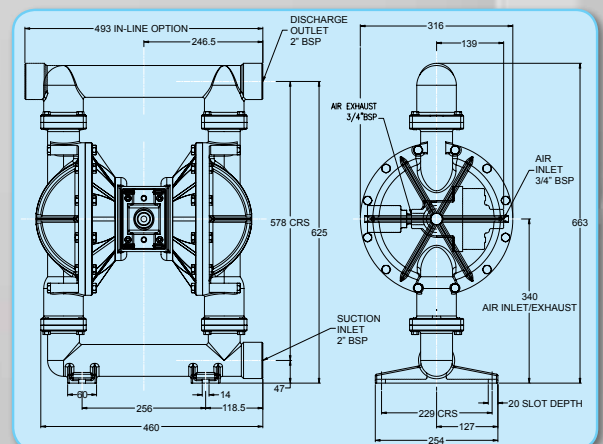

- Simple construction, easy to maintain
- Self priming, ideal for emptying containers
- Pressures to 8.6 bar (125 PSI)
- Flow rates up to 530 litres/minute (140 gal/min)
- Bolted construction for greater integrity
- 316 stainless steel



### TYPICAL CODE = B50.05.SA.BB.BBS-LF

**MODEL - B50: Standard**  
X50: ATEX Approved

**DESIGN LEVEL**

**WETTED COMPONENTS**  
S: 316L STAINLESS STEEL

**NON-WETTED COMPONENTS**  
A: ALUMINUM  
S: 316L STAINLESS STEEL

**VALVE TYPE**  
B: BALL  
W: WEIGHTED

**SUCTION ORIENTATION**  
B: BOTTOM

**LUBE FREE**

**VALVE SEATS**  
B: BUNA-N      A: ALUMINUM  
E: EPDM      V: VITON  
N: NEOPRENE  
S: 316 STAINLESS STEEL

**VALVE BALLS**  
B: BUNA-N      T: PTFE  
E: EPDM      V: VITON  
N: NEOPRENE  
S: 316 STAINLESS STEEL

**DIAPHRAGMS**  
B: BUNA-N  
P: POLYURETHANE  
E: EPDM  
R: SANTROPENE  
H: POLYESTER    T: PTFE  
N: NEOPRENE

### Technical Data

#### METALLIC SERIES B50 STAINLESS STEEL

Maximum Delivery:	530 ltrs/min (140 gal/min)
Max. Working Pressure:	8.6 bar (125 PSI)
Max. Solid Particle Size:	6 mm. (0.24")
Air Inlet:	3/4" NPT
Temperature Limits:	Determined by Elastomers
Suction Lift (Dry):	6.1 m. (20')
Suction Lift (Wet):	7.6 m. (24.9')
Fluid Inlet/Outlet:	2" BSP / NPT
Installation:	Surface mounted
Accessories Included:	Exhaust air Silencer

#### Shipping Weights:

Stainless Steel/Aluminum	70 kg. (154.3 lbs.)
Stainless Steel	95.5 kg. (210.5 lbs.)
Stainless Steel/Cast Iron	95.5 kg. (210.5 lbs.)

**Shipping Dimensions:** 630 x 380 x 670 mm.  
(24.8" x 15" x 26.4")

### Performance Curve

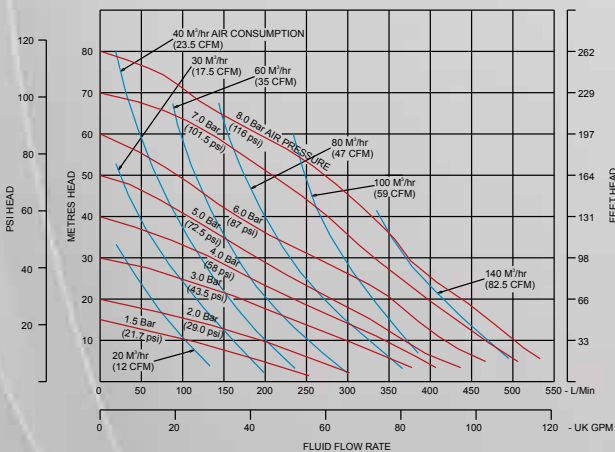

**Note:** The above Performance Curve has been determined under the following conditions: flooded suction, pumping clean water through a calibrated electronic flow meter with pulsation dampener and silencer fitted.

### Dimensions

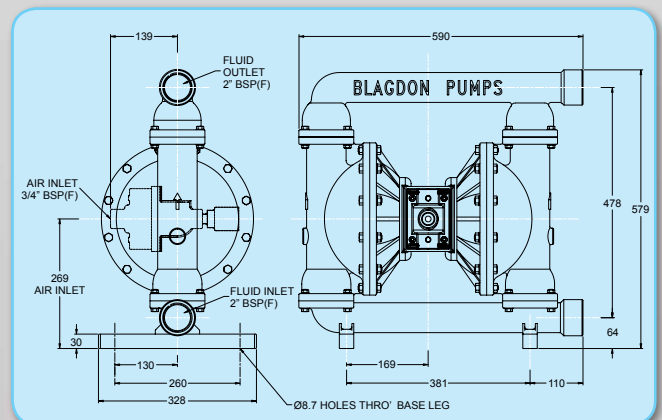



- Robust construction, easy to maintain
- Can easily handle viscous, high S.G. and high head applications
- Smooth action, less vibration and wear
- Pressures to 16 bar (232 PSI)
- Flow rates up to 350 litres/minute (92 gal/min)
- Bolted construction for greater integrity
- Reliable pneumatic air valve
- Stalls against closed head without damage
- Re-start on demand



## TYPICAL CODE = B50. 05. SA. W3. BBS

**MODEL - B50:** Standard  
**X50:** ATEX Approved

**DESIGN LEVEL**

**WETTED COMPONENTS**

A: ALUMINUM  
S: 316 STAINLESS STEEL

**NON-WETTED COMPONENTS**

A: ALUMINUM

**VALVE TYPE**

B: BALL  
W: WEIGHTED

**MODEL DESIGNATION**

**VALVE SEATS**

S: 316 STAINLESS STEEL  
A: ALUMINUM

**VALVE BALLS**

T: PTFE  
N: NEOPRENE  
B: BUNA-N  
E: EPDM  
S: STAINLESS STEEL  
V: VITON

**DIAPHRAGMS**

T: PTFE  
N: NEOPRENE  
B: BUNA-N  
R: SANTOPRENE  
E: EPDM  
H: POLYESTER (HYTREL)  
O: ONE PIECE PTFE  
P: POLYURETHANE  
V: VITON

## Technical Data

### METALLIC SERIES- FULL FLOW 2:1 B50 STAINLESS STEEL, ALUMINUM

Maximum Delivery:	350 ltrs/min (92 gal/min)
Max. Working Pressure:	16 bar (232 PSI)
Max. Solid Particle Size:	6 mm. (0.24")
Air Inlet:	3/4" NPT
Temperature Limits:	Determined by Elastomers
Suction Lift (Dry):	6.1 m. (20')
Suction Lift (Wet):	7.6 m. (24.9')
Fluid Inlet/Outlet:	2" BSP / NPT
Installation:	Surface mounted
Accessories Included:	Exhaust air Silencer

### Shipping Weights:

Stainless Steel/Aluminum	78 kg. (172 lbs.)
Aluminum	52 kg. (114.6 lbs.)

**Shipping Dimensions:** 850 x 450 x 800 mm.  
(33.5" x 17.7" x 31.5")

## Performance Curve

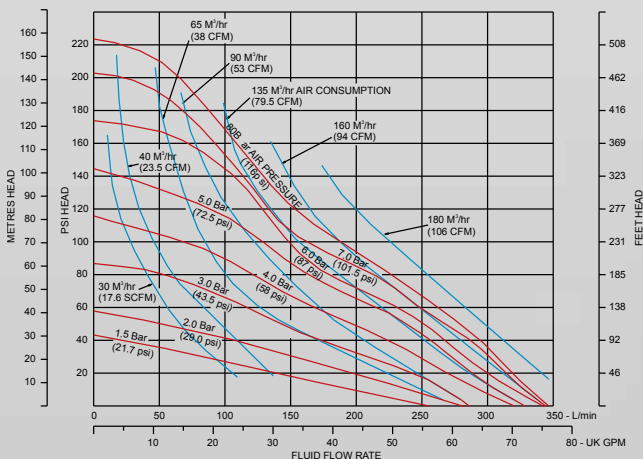

**Note:** The above Performance Curve has been determined under the following conditions: flooded suction, pumping clean water through a calibrated electronic flow meter with pulsation dampener and silencer fitted.

## Dimensions

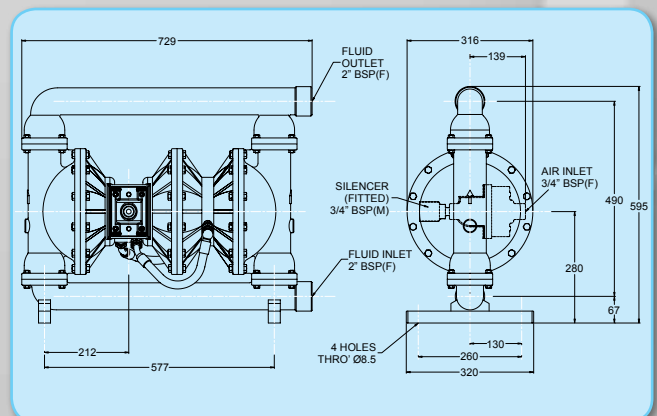

The above drawing shows Stainless Steel only.

- Range of DIN/RJT and ferrule connections
- Self priming, ideal for emptying containers
- Food grade elastomers-EPDM/PTFE
- Pressures to 8.6 bar (125 PSI)
- Capable of handling high viscosity & S.G.
- Certified CIP cleanable
- EU Design approval
- 316L Stainless Steel
- Pump stand option for 180° rotation in place



**TYPICAL CODE = B50.05.ZF.BB.EEE-LF**

**MODEL - B50: Standard**  
X50: ATEX Approved

**DESIGN LEVEL**

**WETTED COMPONENTS**

Z: 316 STAINLESS STEEL  
(ELECTRO POLISHED)

**NON-WETTED COMPONENTS**

S: 316 STAINLESS STEEL  
F: NICKEL PLATED ALUMINUM

**VALVE TYPE**

B: BALL

**SUCTION ORIENTATION**

B: BOTTOM

**LUBE FREE**

**VALVE SEATS**

E: FOOD GRADE EPDM  
T: PTFE

**VALVE BALLS**

E: FOOD GRADE EPDM  
T: PTFE  
S: 316 STAINLESS STEEL

**DIAPHRAGMS**

E: FOOD GRADE EPDM  
O: ONE PIECE PTFE

## Technical Data

### HYGIENIC SERIES B50 STAINLESS STEEL

Maximum Delivery:	500 ltrs/min (132 gal/min)
Max. Working Pressure:	8.6 bar (125 PSI)
Max. Solid Particle Size:	10 mm. (0.39")
Air Inlet:	3/4" NPT
Temperature Limits:	Determined by Elastomers
Suction Lift (Dry):	6.1 m. (20')
Suction Lift (Wet):	7.6 m. (24.9')
Fluid Inlet/Outlet:	2" RJT (Standard)
Installation:	Surface mounted
Accessories Included:	Exhaust air Silencer

### Shipping Weight:

Stainless Steel 64 kg. (141.1 lbs.)

**Shipping Dimensions:** 660 x 430 x 880 mm.  
(26" x 16.9" x 34.7")

## Performance Curve

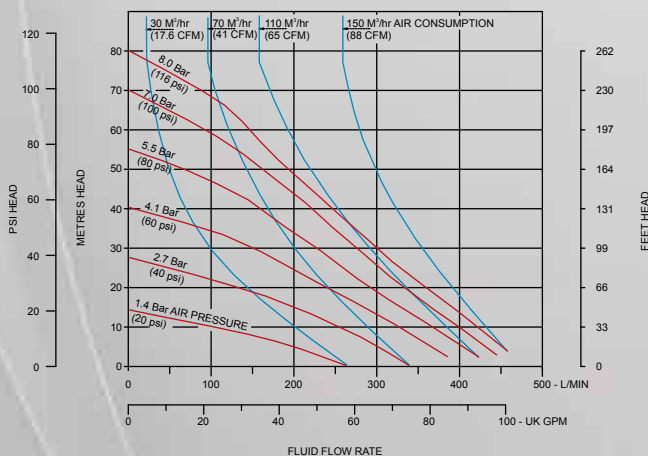

**Note:** The above Performance Curve has been determined under the following conditions: flooded suction, pumping clean water through a calibrated electronic flow meter with pulsation dampener and silencer fitted.

## Dimensions

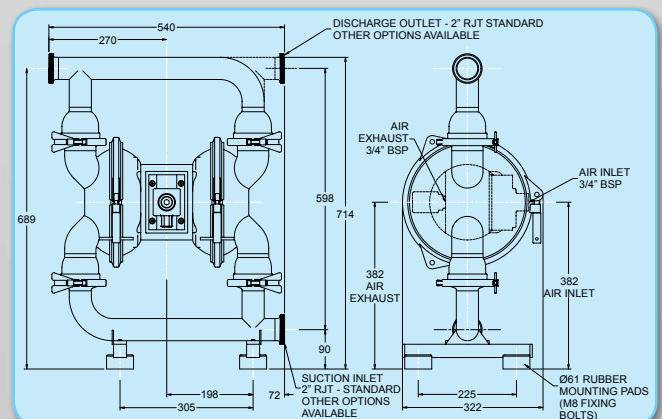

- Simple construction, easy to maintain
- Capable of handling high S.G. and viscous fluids
- Pressures to 7 bar (102 PSI)
- Flow rates up to 901 litres/minute (238 gal/min)
- Adjustable flanged connections
- Reliable, proven pneumatic air valve



**NEW**

**TYPICAL CODE = B75. 02. PT. BB. TTP -LF**

**MODEL - B75: Standard**

**DESIGN LEVEL**

**WETTED COMPONENTS**

P: POLYPROPYLENE  
K: PVDF

**NON-WETTED COMPONENTS**

T: ALUMINUM / EPOXY PAINTED

**VALVE TYPE**

B: BALL  
W: WEIGHTED

**SUCTION ORIENTATION**

B: BOTTOM

**LUBE FREE**

**VALVE SEATS**

P: POLYPROPYLENE  
K: PVDF

**VALVE BALLS**

T: PTFE  
R: SANTOPRENE

**DIAPHRAGMS**

T: PTFE  
R: SANTOPRENE

## Technical Data

### MOULDED NON-METALLIC SERIES B75 POLYPROPYLENE & PVDF

Maximum Delivery:	901 ltrs/min (238 gal/min)
Max. Working Pressure:	7 bar (102 PSI)
Max. Solid Particle Size:	18 mm. (0.71")
Air Inlet:	3/4" NPT
Temperature Limits:	Determined by Elastomers
Suction Lift (Dry):	5.1 m. (16.8')
Fluid Inlet/Outlet:	3" ANSI Flange
Installation:	Surface mounted
Accessories Included:	Exhaust air Silencer

### Shipping Weights:

Polypropylene	105 kg. (231.5 lbs.)
PVDF	143 kg. (315.3 lbs.)

**Shipping Dimensions:** 558 x 965 x 1219 mm. (22" x 38" x 48")

## Performance Curve

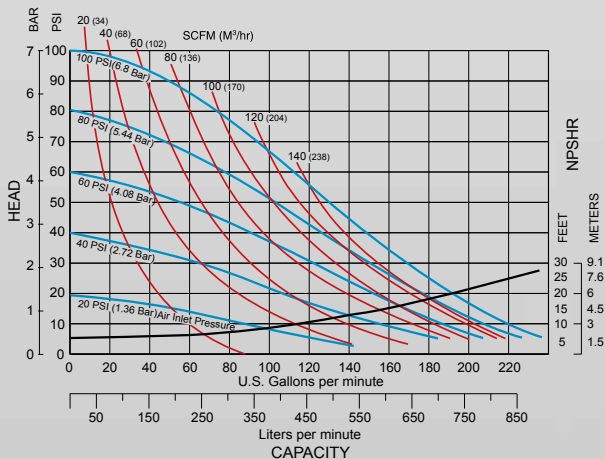

**Note:** The above Performance Curve has been determined under the following conditions: flooded suction, pumping clean water through a calibrated electronic flow meter with pulsation dampener and silencer fitted.

## Dimensions

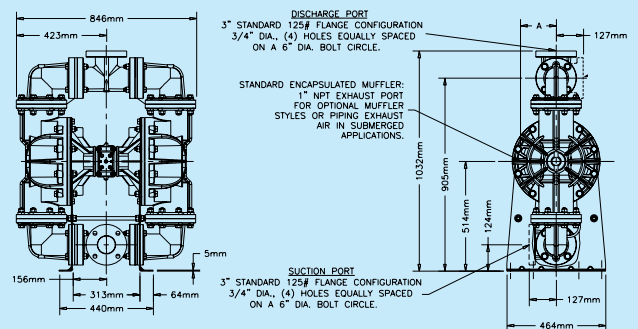

- Air valve will not stall in mid position
- Air valve designed for in-line maintenance
- Available as both end and center ported
- Pressures to 7 bar (102 PSI)
- Flow rates up to 889 litres/minute (234.8 gal/min)
- Bolted construction for greater integrity
- Robust construction



**TYPICAL CODE = B75. 01. AA. BB. BBB**

**MODEL - B75: Standard  
X75: ATEX Approved**

**DESIGN LEVEL**

**WETTED COMPONENTS**

A: ALUMINIUM  
C: CAST IRON  
S: STAINLESS STEEL

**NON-WETTED COMPONENTS**

A: ALUMINIUM  
C: CAST IRON

**VALVE TYPE**

B: BALL  
W: WEIGHTED

**SUCTION ORIENTATION**

B: BOTTOM

**VALVE SEATS**

B: BUNA-N      A: ALUMINIUM  
E: EPDM      T: PTFE  
N: NEOPRENE   V: VITON  
S: 316 STAINLESS STEEL

**VALVE BALLS**

B: BUNA-N  
T: PTFE  
E: EPDM  
R: SANTOPRENE  
N: NEOPRENE

**DIAPHRAGMS**

B: BUNA-N  
V: VITON  
E: EPDM  
T: PTFE  
N: NEOPRENE  
R: SANTOPRENE

## Technical Data

### METALLIC SERIES B75

Maximum Delivery:	889 ltrs/min (234.8 gal/min)
Max. Working Pressure:	7 bar (102 PSI)
Max. Solid Particle Size:	10 mm. (0.4")
Air Inlet:	3/4" NPT
Temperature Limits:	Determined by Elastomers
Suction Lift (Dry):	4 m. (13.1')
Fluid Inlet/Outlet:	3" BSP Tapered (End Ported) DIN Flanged (Center Ported)
Installation:	Surface mounted
Accessories Included:	Exhaust air Silencer

### Shipping Weights:

Aluminium	53.5 kg. (117.7 lbs.)
Cast Iron/Aluminum	90 kg. (198 lbs.)
Stainless Steel/Aluminum	90 kg. (198 lbs.)

**Shipping Dimensions:** 720 x 350 x 900 mm.  
(28.3" x 13.8" x 35.4")

\*End ported version only available in aluminum and cast iron, and center ported versions only available in stainless steel.

## Performance Curve

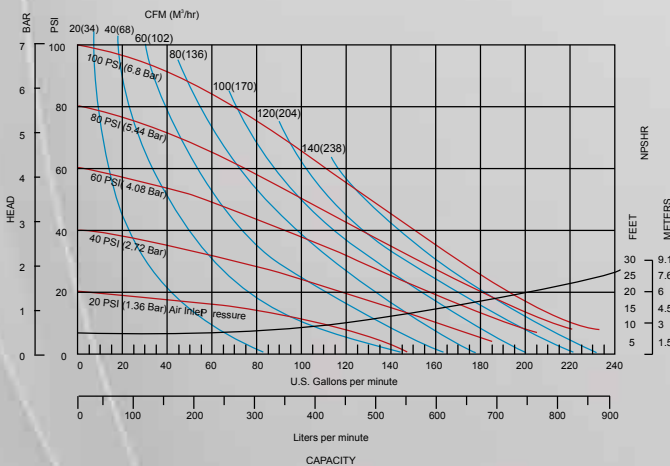

**Note:** The above Performance Curve has been determined under the following conditions: flooded suction, pumping clean water through a calibrated electronic flow meter with pulsation dampener and silencer fitted.

## Dimensions

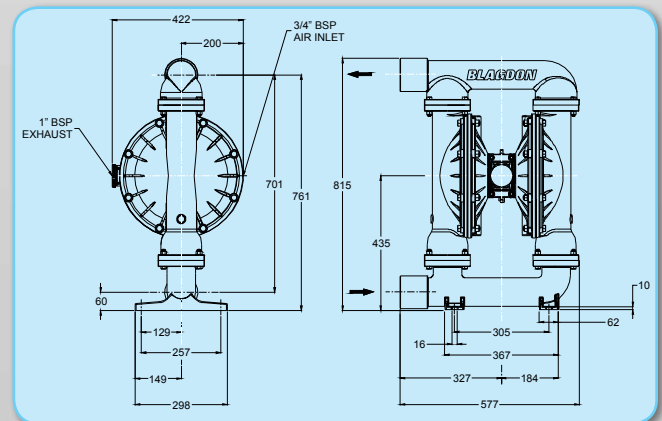

- All bolted construction
- Ball check valves
- Durable diaphragm connecting rod
- Light weight - portable
- 90° - 180° manifold connection rotation
- Solids range +.25" (6mm) to .38" (9.65mm)
- Dry primes up to 20 feet of water
- Complete center section upgrade kits available



AVX75: ATEX Approved

AVB75: Standard

**NEW**

## Characteristics

Standard Duty AirVantage

Fluid Characteristics	Water (Base Reference)	Best Type
	Suspended Solids	Suitable
	Non-Suspended Solids	Limitations
	Line Size Solids	Unsuitable
	Sludge / Slurry	Suitable
	High Viscosity (Flowable Fluids)	Suitable
	Erosion / Abrasive Fluids - High	Suitable
	Erosion / Abrasive Fluids - Moderate	Suitable
	Erosion / Abrasive Fluids - Low	Best Type
	Corrosion	Suitable

Installation	Permanent	Best Type
	Portable	Suitable
	Containment / Prevention	Limitations
	Flooded Suction	Suitable
	Suction Lift	Suitable
	Submerged	Limitations

Duty	Intermittent / On-Demand	Suitable
	Continuous	Best Type

\*End ported version only available in aluminum and cast iron, and center ported versions only available in stainless steel.

## Technical Data

### METALLIC SERIES AVB75 & AVX75

- Maximum Delivery: 889 ltrs/min (235 gal/min)
- Max. Working Pressure: 8.6 bar (125 PSI)
- Max. Solid Particle Size: 9.65 mm. (.38")
- Air Inlet: 3/4" NPT
- Temperature Limits: Determined by Elastomers
- Suction Lift (Dry): 6.1 m. (20')
- Fluid Inlet/Outlet: 3" BSP Tapered (End Ported)  
DIN Flanged (Center Ported)
- Installation: Surface mounted
- Accessories Included: Exhaust air Silencer

## Performance Curve

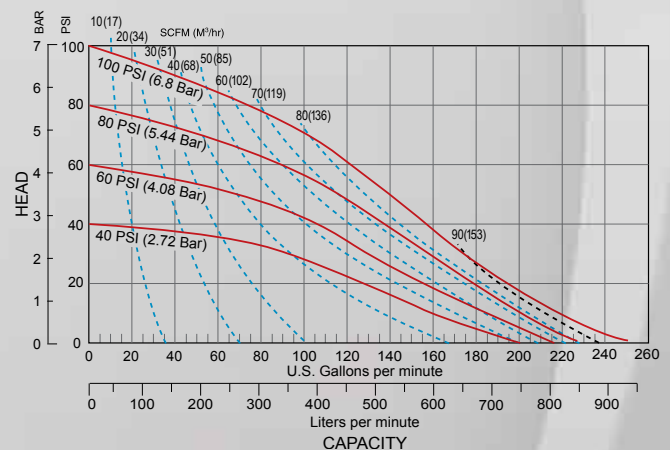

**Note:** The above Performance Curve has been determined under the following conditions: flooded suction, pumping clean water through a calibrated electronic flow meter with pulsation dampener and silencer fitted.



Visit the Blagdon AirVantage website at [www.airvantagepump.com/blagdon](http://www.airvantagepump.com/blagdon) to learn more about this award winning technology.

- Bottom discharge ported for efficient solids handling
- Air valve will not stall in mid position
- Air valve designed for in-line maintenance
- Pressures to 8.6 bar (125 PSI)
- Flow rates up to 265 litres/minute (70 gal/min)
- Bolted construction for greater integrity
- Flap Valve pump for line size solids handling



**NEW**

**TYPICAL CODE = X25. 01. CC. FT. BBS**

**MODEL - X25: ATEX Approved**

**DESIGN LEVEL**

**WETTED COMPONENTS**

A: ALUMINIUM  
C: CAST IRON  
S: STAINLESS STEEL

**NON-WETTED COMPONENTS**

A: ALUMINIUM  
C: CAST IRON

**VALVE TYPE**

F: FLAP

**SUCTION ORIENTATION**

T: TOP

**VALVE SEATS**

S: STAINLESS STEEL

**VALVE FLAPS**

B: NITRILE  
N: NEOPRENE  
R: SANTOPRENE  
P: POLYURETHANE  
H: HYTREL  
V: FKM  
E: EPDM

**DIAPHRAGMS**

B: NITRILE  
R: SANTOPRENE  
N: NEOPRENE  
V: VITON  
E: EPDM  
H: HYTREL

## Technical Data

### METALLIC SERIES X25

Maximum Delivery:	265 ltrs/min (70 gal/min)
Max. Working Pressure:	8.6 bar (125 PSI)
Max. Solid Particle Size:	25 mm. (0.98")
Air Inlet:	1/2" NPT
Temperature Limits:	Determined by Elastomers
Suction Lift (Dry):	5.8 m. (19')
Fluid Inlet/Outlet:	1" BSP Tapered / NPT
Installation:	Surface mounted
Accessories Included:	Exhaust air Silencer

### Shipping Weights:

Aluminium	21 kg. (46.3 lbs.)
Cast Iron	34 kg. (75 lbs.)
Stainless Steel	36 kg. (79.4 lbs.)

**Shipping Dimensions:** 381 x 457 x 482 mm.  
(15" x 18" x 19")

## Performance Curve

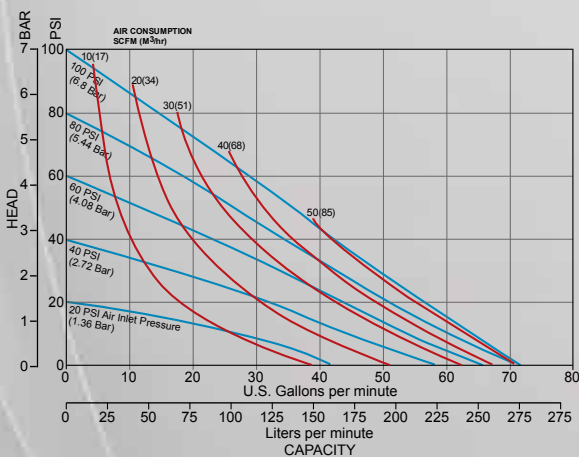

**Note:** The above Performance Curve has been determined under the following conditions: flooded suction, pumping clean water through a calibrated electronic flow meter with pulsation dampener and silencer fitted.

## Dimensions

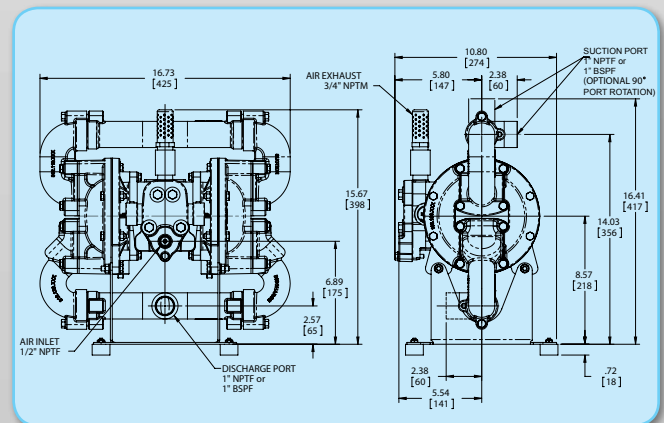

- Simple construction, easy to maintain
- Self priming, ideal for emptying containers
- High quality investment cast design
- Pressures to 8.6 bar (125 PSI)
- Flow rates up to 530 litres/minute (140 gal/min)
- Bolted construction for safety
- Reliable pneumatic air valve system



## TYPICAL CODE = X50. 01. CC. FT. BBS

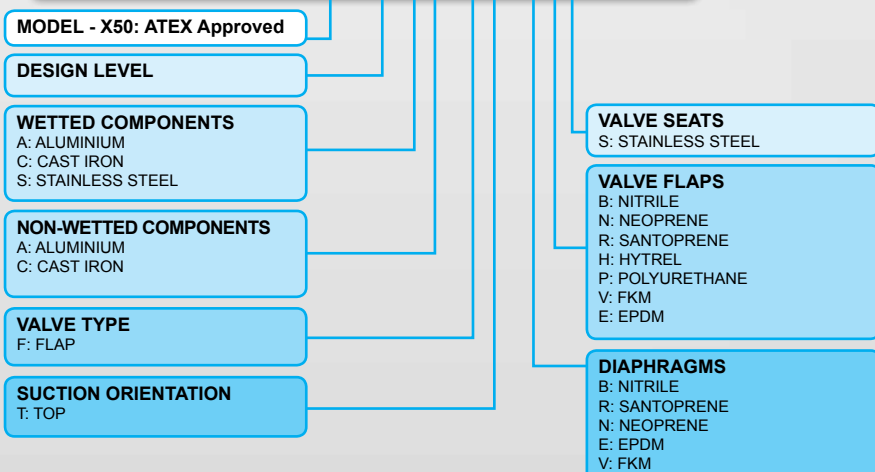

## Technical Data

### METALLIC SERIES X50

Maximum Delivery:	530 ltrs/min (140 gal/min)
Max. Working Pressure:	8.6 bar (125 PSI)
Max. Solid Particle Size:	50 mm. (1.97")
Air Inlet:	3/4" NPT
Temperature Limits:	Determined by Elastomers
Suction Lift (Dry):	7.3 m. (24')
Fluid Inlet/Outlet:	2" NPT
Installation:	Surface mounted
Accessories Included:	Exhaust air Silencer

### Shipping Weights:

Aluminium	39 kg. (86 lbs.)
Cast Iron	76 kg. (167.6 lbs.)
Stainless Steel	76 kg. (167.6 lbs.)

**Shipping Dimensions:** 406 x 584 x 584 mm.  
(16" x 23" x 23")

## Performance Curve

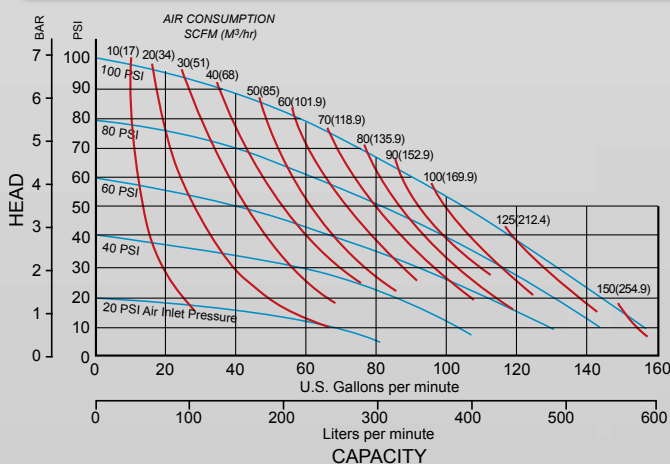

**Note:** The above Performance Curve has been determined under the following conditions: flooded suction, pumping clean water through a calibrated electronic flow meter with pulsation dampener and silencer fitted.

## Dimensions

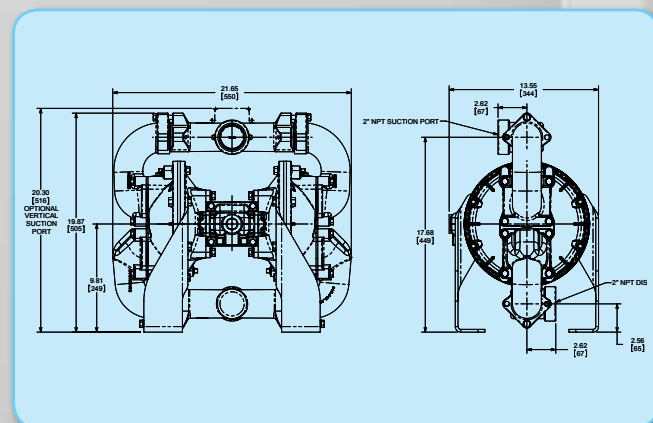

- Bottom discharge ported for efficient solids handling
- Air valve will not stall in mid position
- Air valve designed for in-line maintenance
- Pressures to 8.6 bar (125 PSI)
- Flow rates up to 998 litres/minute (264 gal/min)
- Bolted construction for greater integrity
- Robust construction



**TYPICAL CODE = X75. 01. AA. FT. BBS**

**MODEL - X75: ATEX Approved**

**DESIGN LEVEL**

**WETTED COMPONENTS**  
A: ALUMINIUM

**NON-WETTED COMPONENTS**  
A: ALUMINIUM

**VALVE TYPE**  
F: FLAP

**SUCTION ORIENTATION**  
T: TOP

**VALVE SEATS**  
S: STAINLESS STEEL

**VALVE BALLS**  
B: NITRILE  
N: NEOPRENE  
R: SANTOPRENE  
H: HYTREL  
P: POLYURETHANE

**DIAPHRAGMS**  
B: NITRILE  
R: SANTOPRENE  
N: NEOPRENE

### Technical Data

#### METALLIC SERIES X75

Maximum Delivery:	998 ltrs/min (264 gal/min)
Max. Working Pressure:	8.6 bar (125 PSI)
Max. Solid Particle Size:	75 mm. (3")
Air Inlet:	1/2" NPT
Temperature Limits:	Determined by Elastomers
Suction Lift (Dry):	5.5 m. (18')
Fluid Inlet/Outlet:	3" ANSI Flange
Installation:	Surface mounted
Accessories Included:	Exhaust air Silencer

#### Shipping Weights:

Aluminium 92 kg. (202.8 lbs.)

**Shipping Dimensions:** 533 x 965 x 939 mm.  
(21" x 38" x 37")

### Performance Curve

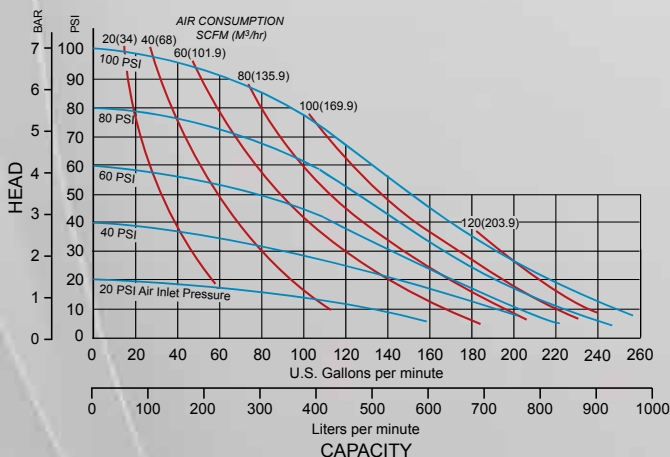

**Note:** The above Performance Curve has been determined under the following conditions: flooded suction, pumping clean water through a calibrated electronic flow meter with pulsation dampener and silencer fitted.

### Dimensions

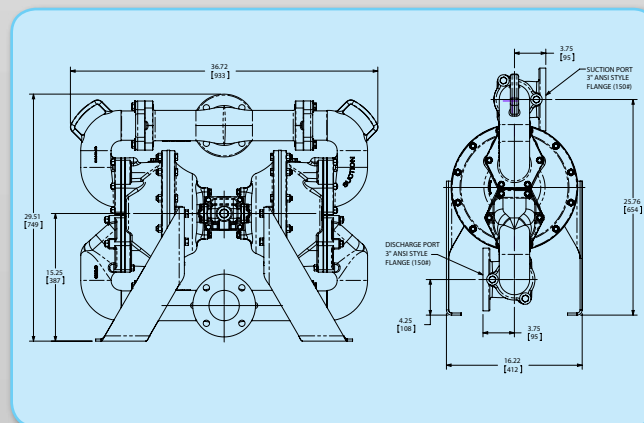



## INDUSTRIES

- Mining
- Construction
- De-watering
- Sewage
- Well-pointing



## Technical Data

### SUBMERSIBLE CENTRIFUGAL PUMP

Maximum Delivery:	560 ltrs/min (148 gal/min)
Max. Working Pressure:	8.6 bar (125 PSI)
Max. Solid Particle Size:	6 mm. (0.24")
Air Inlet:	3/4" NPT
Temperature Limits:	Determined by Elastomers
Suction Lift (Dry):	N/A
Suction Lift (Wet):	N/A
Fluid Inlet/Outlet:	2" BSP / NPT
Installation:	N/A
Accessories Included:	None

### Shipping Weight:

Cast Iron 33 kg. (72.8 lbs.)

**Shipping Dimensions:** 500 x 380 x 260 mm.  
(19.7" x 15" x 10.2")

## Performance Curve

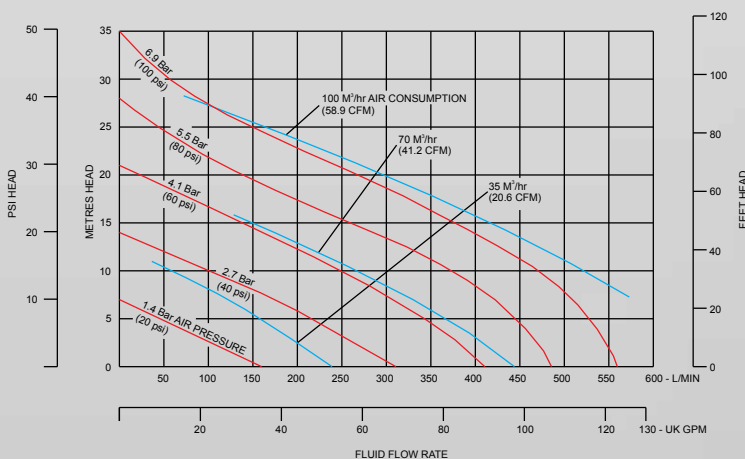

**Note:** The above Performance Curve has been determined under the following conditions: flooded suction, pumping clean water through a calibrated electronic flow meter with pulsation dampener and silencer fitted.

## Dimensions

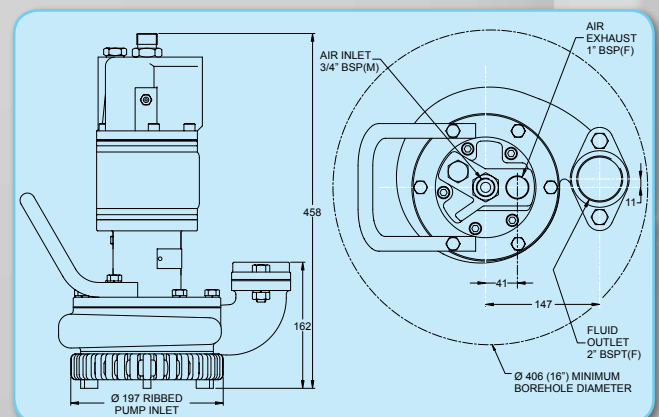



## Pulsation Dampener

- Virtually pulsation free flows
- Steadier pressures
- Less vibration and noise
- Simple installation
- Variety of sizes and materials
- Automatically self changing



## Flanges

- ANSI 150 as standard also available:
  - ANSI 300
  - PN16
  - Food Industry - RJT, DIN, TRI-CLAMP
- Ease of connections to pipework systems



## Valve Block with Sensors

- Batch Control
- Linkage to control equipment
- Greater process control
- 10 - 30v DC, PNP normally open



## Oil Bottle Assembly

- Exclusive to Blagdon Pump
- Robust heavy duty design
- Suitable for arduous installations
- Safe for underground use - no aluminium

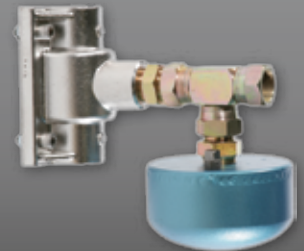

## Filter Regulators

- Maintains constant oil density with varying flow
- Remote installation for ease of maintenance
- Ensures clean, filtered air
- Can be controlled independently of other equipment



## Center Section

- Upgrade B75 and X75 pumps to AirVantage
- Simply install a complete air section kit





## Visit Our Website Today

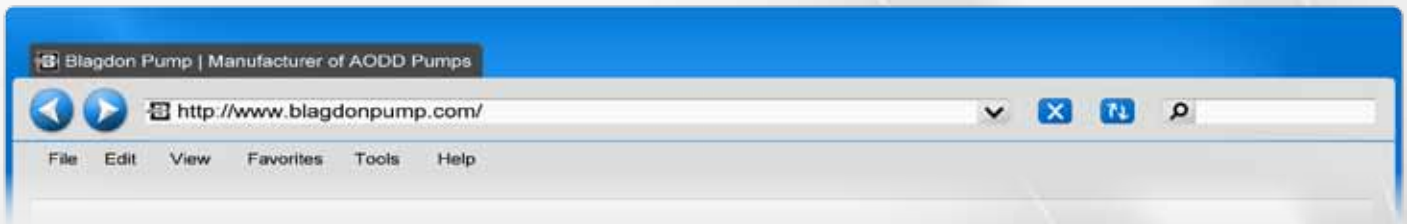

The purpose of our website is to have as much information as possible available to our customers.

### Also shown within the web pages are:

- Chemical Resistance Charts
- Kit Revisions
- Index with Components and Drawings
- Viscosity Correction Curve
- Flow Rate Conversion Calculator
- Shipping Weights and Dimensions
- Blagdon Numbering System



### Product Literature

Product specific literature is available which includes:

- Technical data
- Performance Curves
- Applicable industries/applications
- Available options



## BLAGDON PUMP

R79 Shannon Industrial Estate, Shannon, Co. Clare, Ireland

Phone: +353 (0) 61 471933 • Fax: +353 (0) 61 475046

[sales.blagdonpump@idexcorp.com](mailto:sales.blagdonpump@idexcorp.com)

[www.blagdonpump.com](http://www.blagdonpump.com)

### **NORTH AMERICA COMMERCIAL OPERATIONS**

#### **Warren Rupp, Inc.**

800 North Main Street  
Mansfield, Ohio 44901  
Phone: 419-524-8388  
Fax: 419-522-7867

[Appeng.warrenrupp@idexcorp.com](mailto:Appeng.warrenrupp@idexcorp.com)  
[www.warrenrupp.com](http://www.warrenrupp.com)

#### **Viking Pump of Canada, Inc.**

661 Grove Avenue  
Windsor, Ontario  
N9A 6M3, Canada

[www.vikingpumpcanada.com](http://www.vikingpumpcanada.com)

### **Local Distributor**



### **LATIN AMERICA COMMERCIAL OPERATIONS**

#### **IDEX de Brazil**

Municipal dos Andradas Road – Building 8  
Valinhos – São Paulo – Brazil  
Phone: +55 19 3871-3500  
Fax: +55 19 3871-6400  
[ftorres@idexcorp.com](mailto:ftorres@idexcorp.com)  
[www.idexcorp.com](http://www.idexcorp.com)

#### **IDEX Mexico**

Ejército Nacional #404-801  
Col. Chapultepec Morales,  
C.P. 11570, México, D.F.  
Phone: +52 55 5255 1357  
Fax: +52 55 5255 1356  
[raguilar@idexcorp.com](mailto:raguilar@idexcorp.com)  
[www.idexcorp.com](http://www.idexcorp.com)

### **ASIAN COMMERCIAL OPERATIONS**

#### **IDEX Asia Pacific Pte Ltd**

63 Hillview Avenue, #07-08,  
Lam Soon Industrial Building, Singapore 669569  
Phone: +65-63146146  
Fax: +65-6764 4020  
[mhim@idexcorp.com](mailto:mhim@idexcorp.com)  
[www.idexcorp.com](http://www.idexcorp.com)

### **WEST ASIA COMMERCIAL OPERATIONS**

#### **IDEX India Pvt Ltd**

Sunteck Centre, 3rd floor, 37-40 Subhash Road  
Vile Parle East, Mumbai-400 057, India  
Phone: +91-22-6643 5500  
Fax: +91-22-6678 0055  
[rgupta@idexcorp.com](mailto:rgupta@idexcorp.com)  
[www.idexcorp.com](http://www.idexcorp.com)

### **EAST ASIA COMMERCIAL OPERATIONS**

#### **IDEX Trading (SHANGHAI) CO., LTD.**

Room 3502-3505, Zhao Feng Plaza,  
1027 Chang Ning Road, Shanghai 200050, China  
Phone: +86-21-52415599  
Fax: +86-21-52418339  
[jzhao@idexcorp.com](mailto:jzhao@idexcorp.com)  
[www.idexcorp.com](http://www.idexcorp.com)

Distributors located globally – for channel partners please visit:

[www.blagdonpump.com](http://www.blagdonpump.com)

**IDEX**  
CORPORATION